

RECHARGEABLE WALL SCANNER DWD181

REPAIR MANUAL



1 CONTENTS

1	CONTENTS	2
2	CAUTION	4
3	SAFETY PRECAUTIONS	5
3-1	Level of Danger.....	5
3-2	Description of Hazard Symbols.....	5
3-3	Notes on repair.....	8
3-4	Tightening torque specifications	8
3-5	Abbreviations.....	8
3-6	Necessary repairing tools	8
4	Caution on Repairing.....	9
4-1	Torque driver setting	10
4-2	Handling of Packing after disassembling	11
4-3	Orientation and Fitting of Packing in assembly	12
4-4	Connector lock of Flexible harness	13
5	NAME OF PARTS	14
5-1	Names of exterior parts	14
5-2	Names of operation buttons	15
6	FLOWCHART FOR TROUBLESHOOTING	16
6-1	The machine does not start up.....	16
6-2	Screen freezes or stops automatically.....	17
7	Check of Error code and Replacement of Repair parts to resolve the trouble.....	18
7-1-1	Check of Automatic stop due to Abnormal temperature	18
7-1-2	Error code on Automatically stops and Repair parts	19
7-2	Replace parts in accordance with Error code	20
7-3	Operation buttons do not work.....	21
7-4	Laser/ Light does not light up.....	22
7-5	Detection results do not appear.....	23
7-6	Wheels worn out.....	24
8	REPAIR	25
8-1	Upper/ Lower case section	25
8-1-1	Upper case assembly/ Disassembling.....	25
8-1-2	Lower case assembly/ Replacement, Assembling	27
8-2	FFC section	28
8-2-1	Disassembling	28
8-2-2	Assembling.....	28
8-3	Upper case assembly.....	29
8-3-1	Assembling.....	29
8-4	LCD assembly section	30
8-4-1	Disassembling 1	30
8-4-2	Disassembling 2	32
8-5	Switch assembly section	33
8-5-1	Replacing.....	33
8-6	LCD assembly section	34
8-6-1	Assembling.....	34
8-6-2	Replacing.....	36
8-7	Sensor assembly section.....	38
8-7-1	Removing	38
8-7-2	Replace/ Assembling	38
8-8	Case L/ R assembly section.....	39
8-8-1	Disassembling	39
8-8-2	Assembling.....	40
8-9	PCB/ LED section.....	43
8-9-1	Replacing.....	43
8-10	Harness set/ LED section	44
8-10-1	Replacing.....	44
8-11	Terminal assembly section	44
8-11-1	Replacing.....	44
8-12	Wheel set section	45
8-12-1	Replacing.....	45
9	PROPER OPERATION CHECK.....	47

9-1	Check of Activate operation.....	47
9-2	Check of Button operation	47
9-3	Check of Lighting	48
9-4	Check of Laser lighting	49
9-5	Check of Detection result image	49
9-5-1	The method of Confirmation of Detection with using Reference instrument.....	49
9-5-2	The method of Simple confirmation of Detection without using Reference instrument	50

2 CAUTION

Repair the machine in accordance with "Instruction manual" or "Safety instructions".

Follow the instructions described below in advance before repairing:

- Wear gloves.
- In order to avoid wrong reassembly, draw or write down where and how the parts are assembled, and what the parts are.
It is also recommended to have boxes ready to keep disassembled parts by group.
- Handle the disassembled parts carefully. Clean and wash them properly.
- Remove Battery, except when it is necessary to check the operation of the machine.



3 SAFETY PRECAUTIONS

Be sure to read these precautions before using the machine.



3-1 Level of Danger

Read the safety instructions in this manual carefully before using the machine.













Be sure to follow the instructions described here because they contain important safety instructions.

	WARNING	This indicates a potentially hazardous situation which, if ignored, could result in death or serious injury.
	CAUTION	This indicates a potentially hazardous situation which, if ignored, could result in injury or property damage* (*Expanded damage related to houses, household goods, livestock and pets)











3-2 Description of Hazard Symbols

	Triangular symbols intend to alert the user to a present or potential hazard. The pictogram in the triangle specifically indicates the hazard to be warned or cautioned of. There may be a supplementary explanation beside some symbols as shown in 3-1.
	Prohibition symbols (a circle with a backslash) warn the user that an act is prohibited. The pictogram in the circle specifically indicates the prohibited act. There may be a supplementary explanation beside some symbols.
	Solid circular symbols indicate that the user must follow an instruction. The pictogram in the circle specifically indicates the instruction to follow. There may be a supplementary explanation beside some symbols.

⚠ WARNING

	Do not use the machine in a place with high humidity, dust, or oil smoke; a place with poor ventilation; or a place with fire. Failure to follow this instruction might cause breakdown, fire or electric shock.
	Do not use Batteries other than recommended or compatible genuine Makita Batteries listed in this manual. Failure to follow this instruction might cause fire or electric shock.
	Do not insert or remove Battery with wet hands. Failure to follow this instruction might cause electric shock.
	Do not damage or modify Terminal assembly. If the assembly is heavily weighted down, pulled, forcibly bent, twisted, clamped, or heated for modification, it might be damaged, resulting in fire or electric shock.
	Do not use the machine with a broken Terminal assembly. Failure to follow this instruction might cause fire or electric shock.
	If there is foreign matter (water, metal fragments, liquid, dust, etc.) on the contact plates of Terminal assembly, wipe it thoroughly with a dry cloth. Failure to follow this instruction might cause fire.
	If the machine emits heat, smoke, odor, or noise, remove Battery immediately. Failure to follow this instruction might cause fire or electric shock.
	Do not attempt to modify the machine. Failure to follow this instruction might cause fire or electric shock.
	Do not use the machine in abnormal condition. Failure to follow this instruction might cause fire or electric shock.
	In case of accident resulting in personal injury such as electric shock or burns, immediately treat the injured person and ensure his/her safety.
	When disposing of the machine at the end of its lifecycle, do not mix it with any other waste. Be sure to contract with an industrial waste disposal company for proper disposal through them.
	Be sure to contact us, if a problem persists even after taking the measures described in this manual. Any adjustment or repair not instructed in this manual might result in electric shock, injury or fire.

⚠️ Note

	Before starting repair, make sure that around the machine, there is a space which is large and lit properly enough to provide safe operation.
	The service person should be a skilled person with appropriate professional knowledge, and should read this manual carefully before starting repair. Failure to follow this instruction might cause injury or breakdown.
	Do not loosen/tighten the screws securing the parts not mentioned in this manual. Failure to follow this instruction might cause electric shock or injury.
	Do not work near a TV, speaker, wireless device or mobile phone where strong magnetic fields or radio waves are generated. Failure to follow this instruction might cause malfunction or breakdown of the machine.
	Do not place heavy objects on top of the machine. Do not drop an object on the machine or do not strike blows to the machine. Failure to follow this instruction might cause breakdown or malfunction.
	Do not use volatile organic solvents or chemicals such as benzine or thinner; chemical cloths; or pesticides. Failure to follow this instruction might cause discoloration or breakdown.
	Do not touch LCD screen with pointed objects or corners of hard objects. Failure to follow this instruction might cause scratches or damage to the screen.
	Do not tip over the machine or hit it with anything. Also, do not place the machine on unstable surfaces such as a wobbly workbench or sloped surface. Failure to follow this instruction might result in drop or overturn of the machine to cause injury or damage to internal mechanisms or sensors.
	Always remove Battery from Terminal assembly for safety when the machine is not in use for a long time.
	Do not use or leave a damaged machine. Failure to follow this instruction might cause breakdown, fire, electric shock or injury.
	Corrosive gases and salty air can corrode the machine, resulting in malfunction, damage or a significantly shorter service life. Therefore, it is necessary to take measures such as installing an air purifier. Also dusty environments may cause damage, malfunction or a significantly shorter service life of memory devices. The major sources of corrosive gas production include chemical plant areas, hot springs and volcanic regions. Salty air damage is remarkable in the regions roughly within 500m from coastline.

3-3 Notes on repair

- Do not use reused parts.
- Perform repair work in an anti-static environment.
- Be sure to use the specified repair parts.
- Use the specified screws to assemble repair parts.
- Please observe the specified tightening torques.
- Recommended tool: Torque driver

3-4 Tightening torque specifications

- Screw M2.5x6 (a component of Wheel set): 0.35 N·m
- Tapping screw M3x16: 1.10 N·m
- Tapping screw 3x8: 0.80 N·m
- Tapping screw PT M2.3x8: 0.40 N·m

3-5 Abbreviations

- LCD: Liquid Crystal Display
- LED: Light Emitting Diode (used as illuminating lights on Front, Left, and Right, and LED on the board.)
- FFC: Flexible Flat Cable (to connect LCD assembly and Sensor assembly)
- PCB: Printed Circuit Board

3-6 Necessary repairing tools

- No.1 Phillips screwdriver
- No.2 Phillips screwdriver



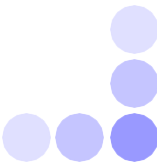
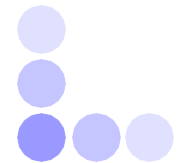

4 Caution on Repairing



Tighten Screws to the specified torque by $\pm 10\%$.

Otherwise, Screw looseness by insufficient torque or damage by excessive torque may occur, and the waterproof performance may be badly affected.

Set the torque according to the used screws in advance.

Description	Figure	Torque
Screw M2.5x6 (Component parts of Wheel set)		$0.35\text{N}\cdot\text{m}\pm 10\%$
Tapping screw 2.3x8		$0.4\text{N}\cdot\text{m}\pm 10\%$
Tapping screw 3x8		$0.8\text{N}\cdot\text{m}\pm 10\%$
Tapping screw M3x16		$1.1\text{N}\cdot\text{m}\pm 10\%$

Once Packing is removed. Replace it with a new one.
Otherwise, the waterproof performance may be badly affected.

1 Case R/ L Assy section



Packing B/ C set

2 Lower case assy section

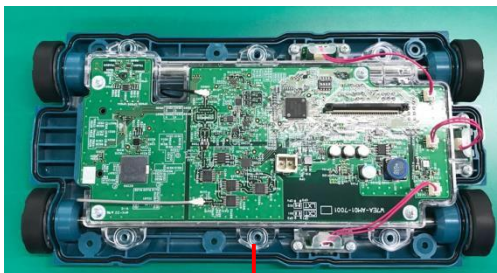

Packing D

3 LCD assy section

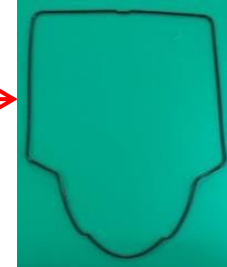
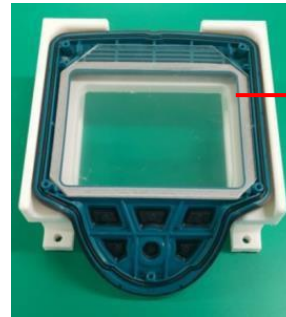

Packing A

4 Tapping screw 3x16

Once Tapping screw 3x16 is removed, replace it with a new one. Otherwise, the waterproof performance may be badly affected.





Packing A



The orientation of Packing D and Lower case when assembling.



Packing D

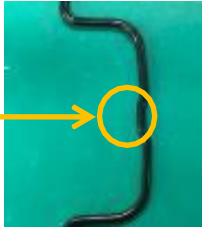

With Notch

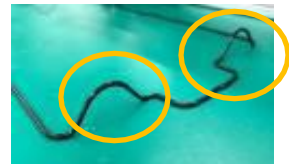

Arc faces upward.



The orientation of Packing A and LCD case/ Packing D and Lower case matter. Packings will be float if they are assembled in opposite.

The wrong orientation in assembly may cause a decline of Waterproof or a pinch of Packing, therefore, be careful to their orientations.

4-4 Connector lock of Flexible harness

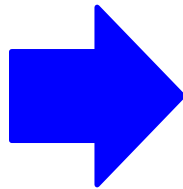
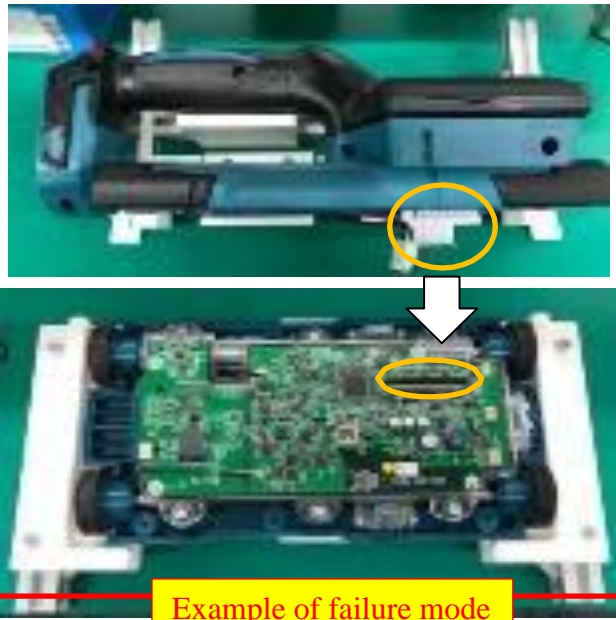

Locks are up.



Insert FFC straight to the full.



Insert FFC so that left and right protrusions touch CN.



Lock both ends of Connector. Push and lock both ends of the round portion.

Insert FFC in the same way on LCD assy.

Example of failure mode



Half lock

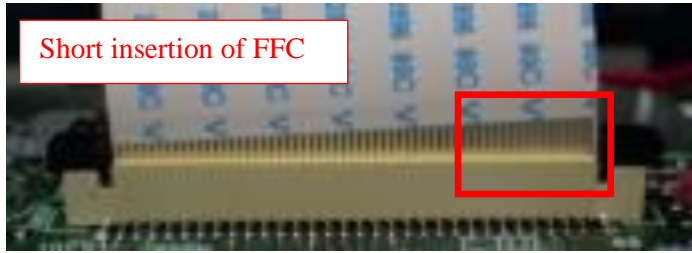

Short insertion of FFC

5 NAME OF PARTS
5-1 Names of exterior parts

Fig.1

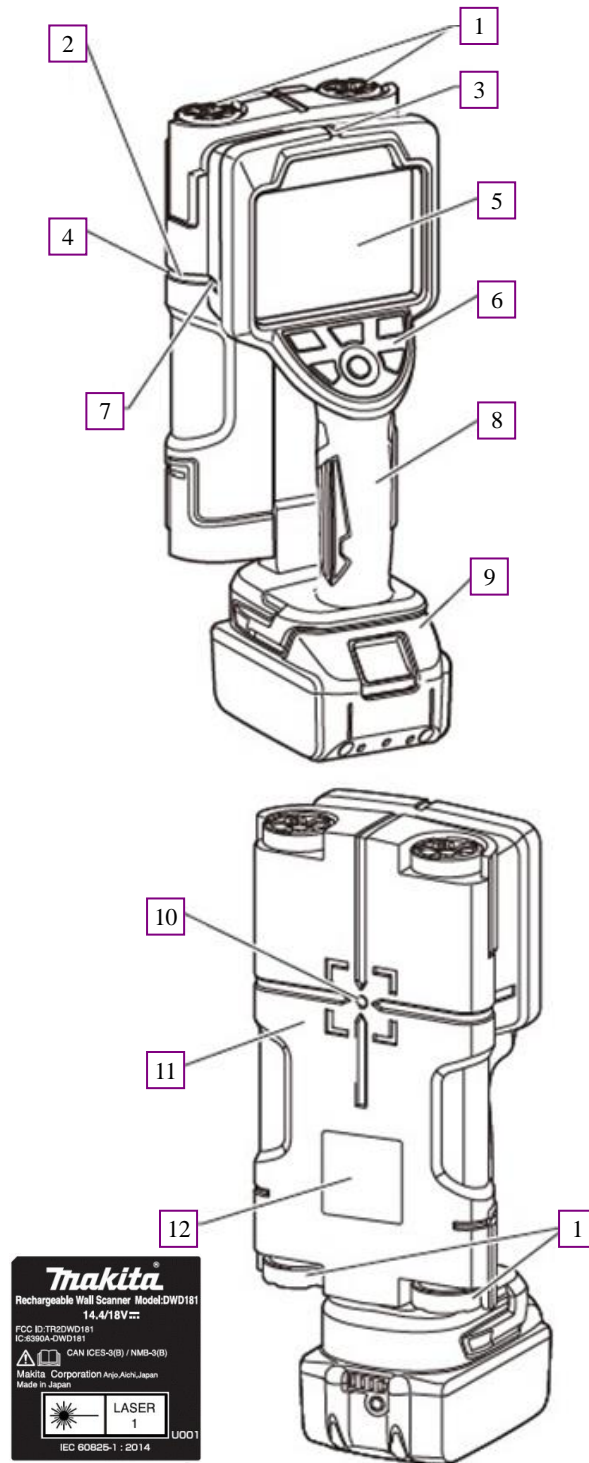

1	Wheels	7	Guide laser
2	Sensor's Left edge line (Right edge line)	8	Handle
3	Sensor's center line	9	Battery (Option)
4	Light	10	Sensor's center point
5	Display	11	Sensor surface
6	Operation buttons (6 buttons)	12	Product label (name plate)

5-2 Names of operation buttons

Fig.2

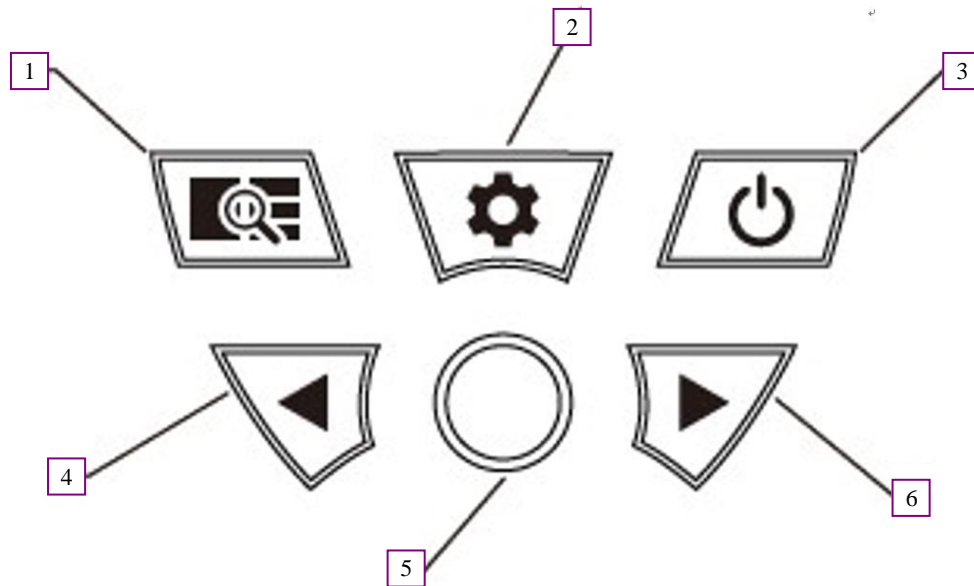

1	Mode button	Navigates to the scan mode selection screen.
2	Setting button	<ul style="list-style-type: none"> • Navigates from your current screen to the setting screen. • Goes back from the settings screen to the previous screen.
3	Power button	Turns ON/ OFF the power. ON (startup): Press, OFF (shutdown): Press and hold (2 seconds)
4	Left button	Moves the cursor to the left to select an item, etc.
5	Apply button	<ul style="list-style-type: none"> • Applies the operation/ selection that you have made. • Clears data when a scan has been completed to reset to the scan start status.
6	Right button	Moves the cursor to the right to select an item, etc.

6 FLOWCHART FOR TROUBLESHOOTING

Note: In case of repairing, remove battery then start repairing. If Power button is "ON", turn it to "OFF", then remove Battery.

6-1 The machine does not start up.

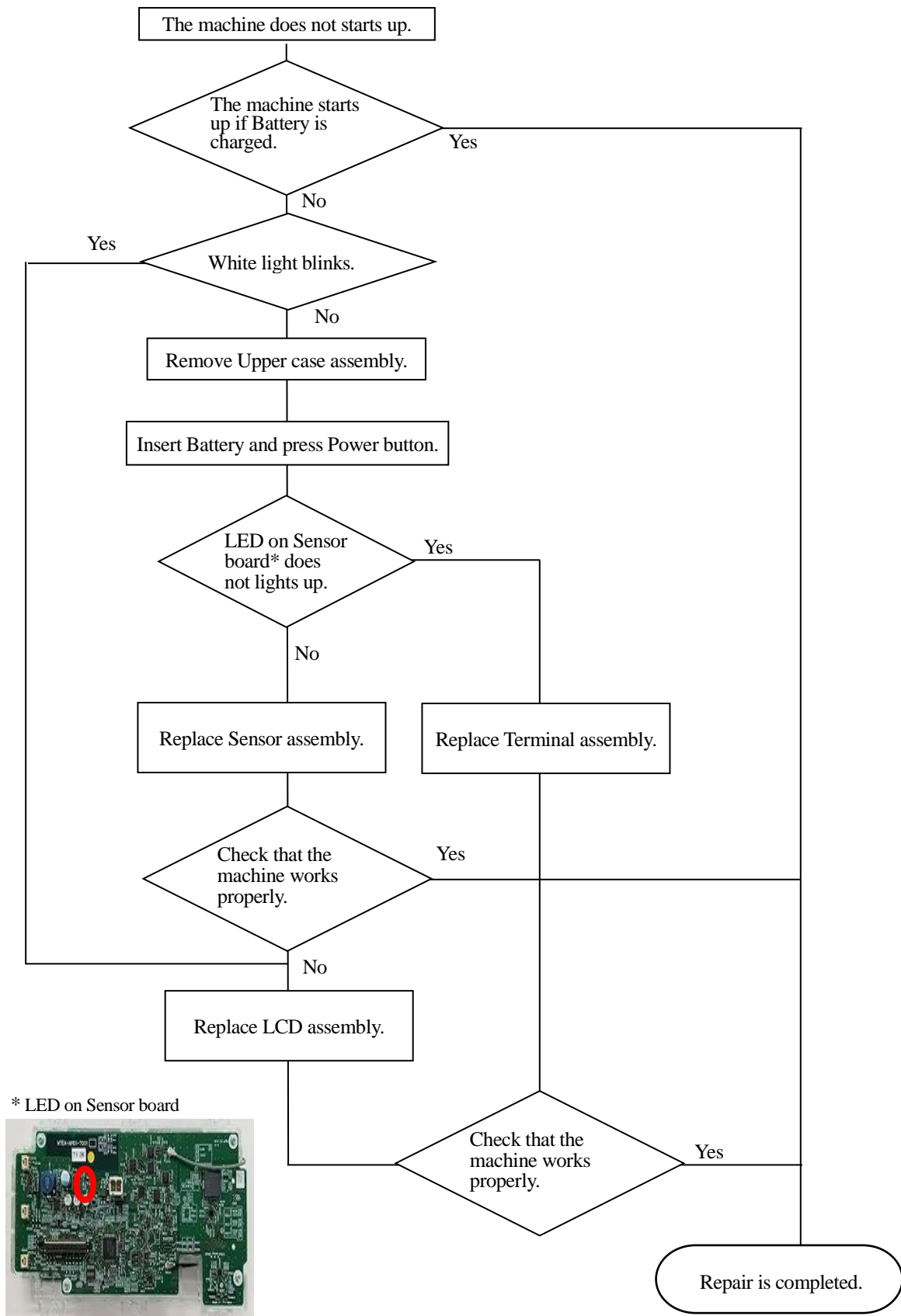

6-2 Screen freezes or stops automatically.

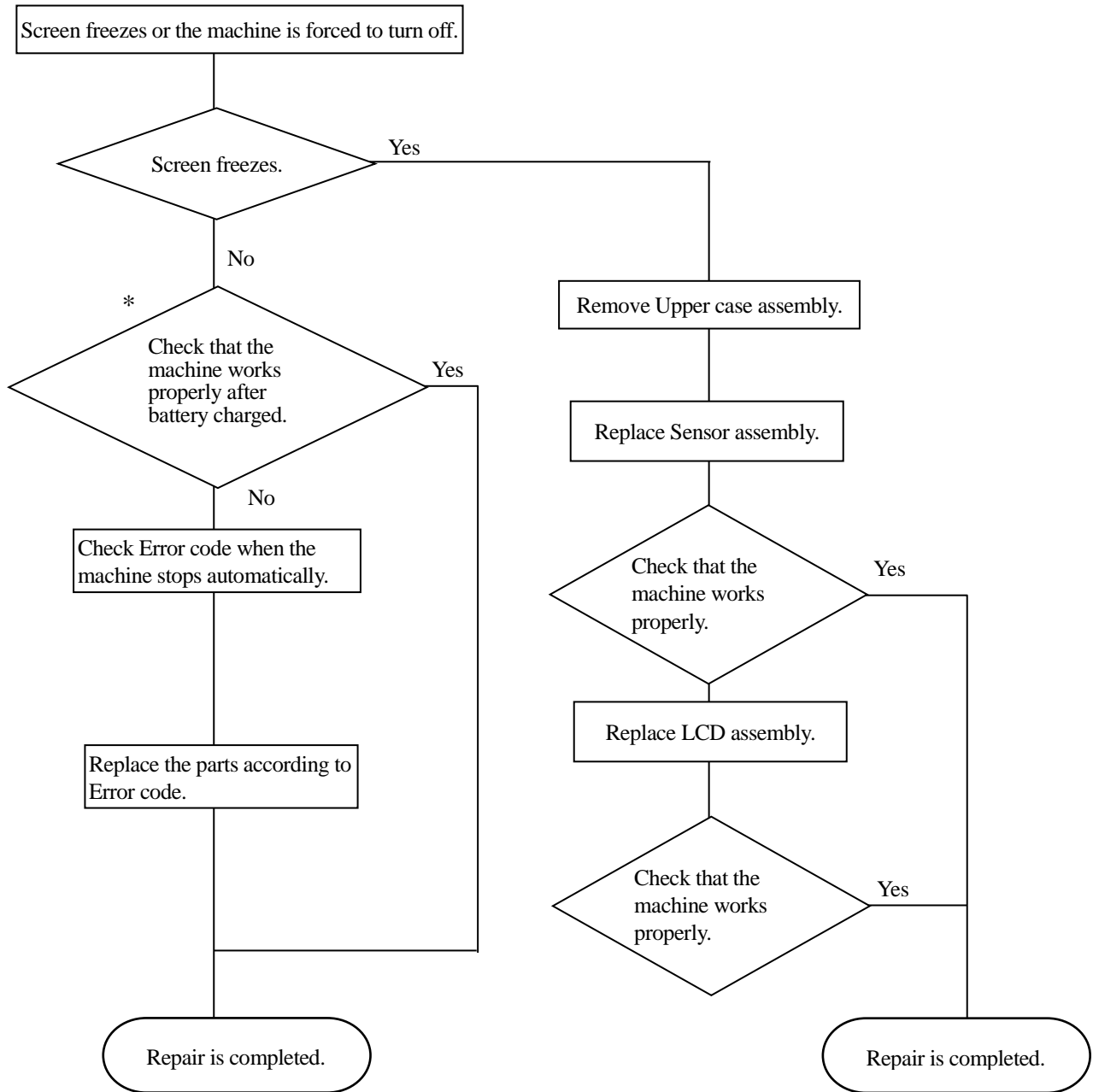

* Operate in the normal temperature and check whether the problem is solved.

7 Check of Error code and Replacement of Repair parts to resolve the trouble

Check of Error code on Automatic stops

Error message and Error code appear on the screen and the machine is forced to turn off.

*The machine stops automatically after approximate 5 seconds of Error screen.

*Error codes are displayed in with "E○○". (Below is the example of Error code "E90".) See more details in [7-1-1](#).

*Repair according to Error code and follow the flowchart.

Screen display and its Error code at trouble when Automatic stop is activated

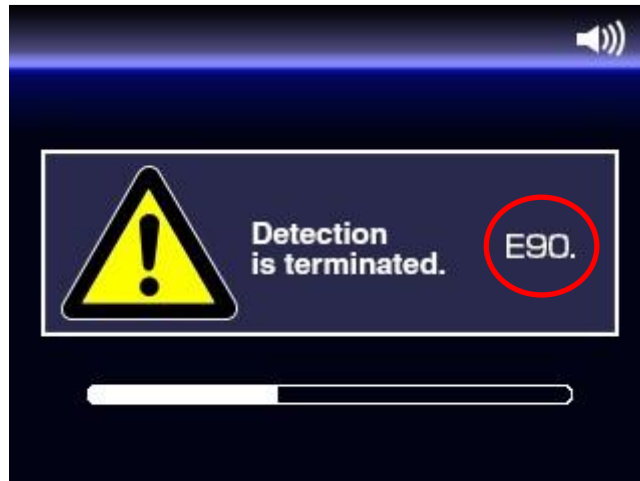

7-1-1 Check of Automatic stop due to Abnormal temperature

The following message appears and the machine is forced to turn off due to abnormal temperature.

The machine is forced to turn off after the view of Error screen approximate 5 second.

If the trouble is not solved even after restarting in normal temperature, repair according to the flowchart. Replace parts in accordance with Error code". (If the abnormal temperature trouble disappears in a normal temperature environment, the machine is in order.)

Screen display example at Abnormal temperature



7-1-2 Error code on Automatically stops and Repair parts

Error code	Error Name	Screen at stop	Error Description	Parts to replace
E21	Temperature acquisition failure	Internal error screen	The temperature cannot be acquired or shows abnormal value.	<ul style="list-style-type: none"> • FFC • Sensor assembly • LCD assembly
E22	Voltage acquisition failure	Internal error screen	Voltage cannot be acquired or shows abnormal value.	
E30	Encoder phase error	Internal error screen	The encoder counter is not updated correctly in succession. (Possibility of the component failure)	<ul style="list-style-type: none"> • Sensor assembly • Lower case assembly
E31	Radar section disconnecting	Internal error screen	The radar is not activated or cannot be connected.	<ul style="list-style-type: none"> • FFC • Sensor assembly • LCD assembly
E32	Radar communication error	Internal error screen	By disrupting communications with the radar or an abnormal value was received.	
E33	Radar antenna error	Internal error screen	The antenna initialization of the radar failed. (Correct waveform cannot be acquired.)	
E34	Encoder failure error	Internal error screen	The encoder counter is not updated correctly. (Failure of photo sensor, etc.)	<ul style="list-style-type: none"> • Sensor assembly • Lower case assembly
E35	Reference voltage offset error	Internal error screen	The reference voltage setting of the radar section failed. (Correct waveform cannot be acquired.)	<ul style="list-style-type: none"> • Sensor assembly
E36	Reference data read error	Internal error screen	Reading of reference data from Radar section failed. (Information of Radar section)	
E37	Depth correction value reading error	Internal error screen	Failed to read the depth correction value. (Information of Radar section)	
E38	Connection information reading error	Internal error screen	Failed to read maintenance information (version, etc.). (Information of Radar section)	
E39	PGA setting value reading error	Internal error screen	Failed to read PGA setting value. (Information of Radar section)	
E40	Screen program stop	Internal error screen	The screen task has stopped.	<ul style="list-style-type: none"> • LCD assembly
E41	Screen data error	Internal error screen	The screen data (file) is damaged, or cannot be read.	
E45	Control program stop	Internal error screen	The UI management task has stopped.	
E90	Processing error	Internal error screen	An error was detected in the program. The detailed logs are recorded to the internal logs.	

7-2 Replace parts in accordance with Error code

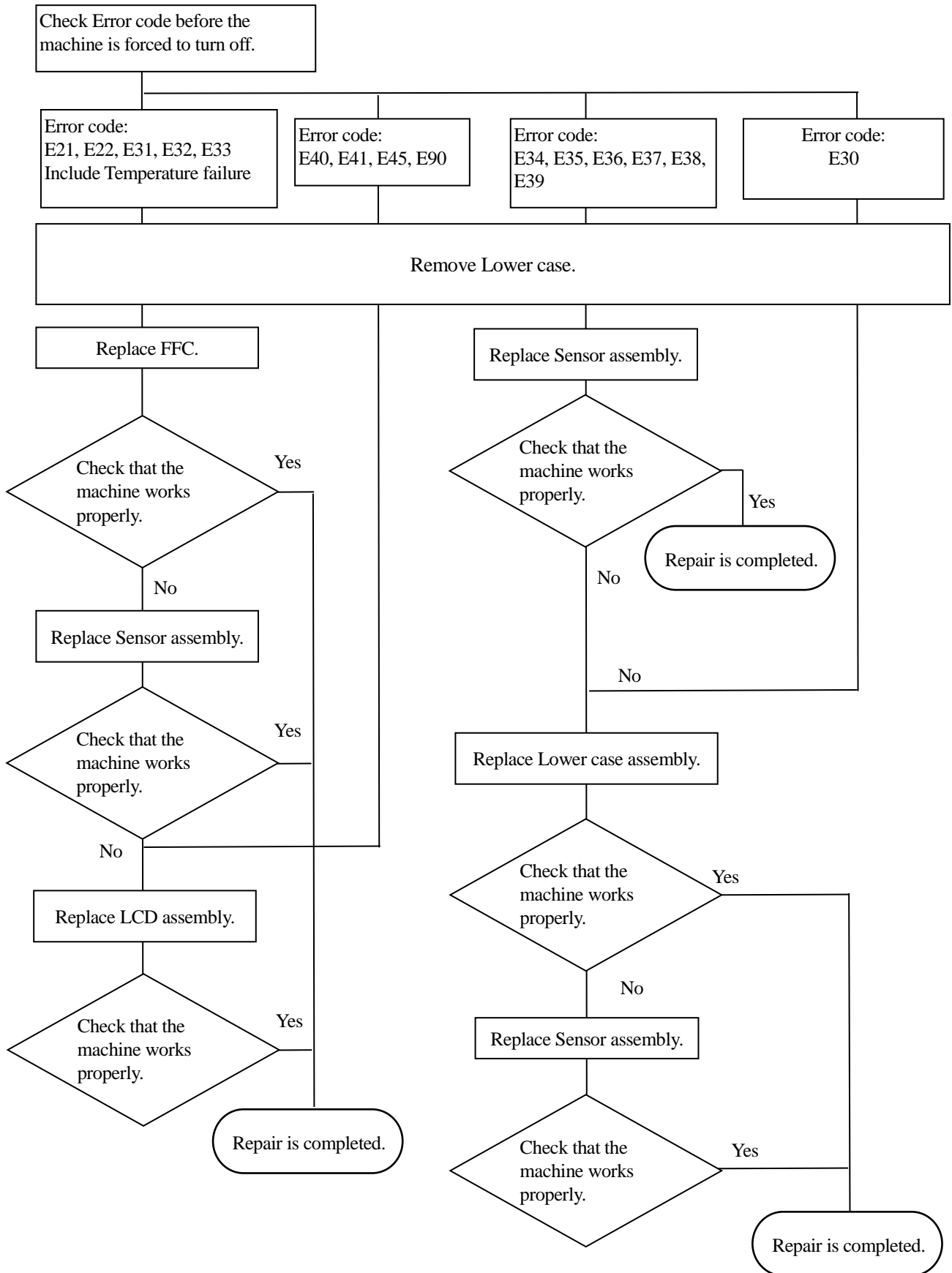

7-3 Operation buttons do not work.

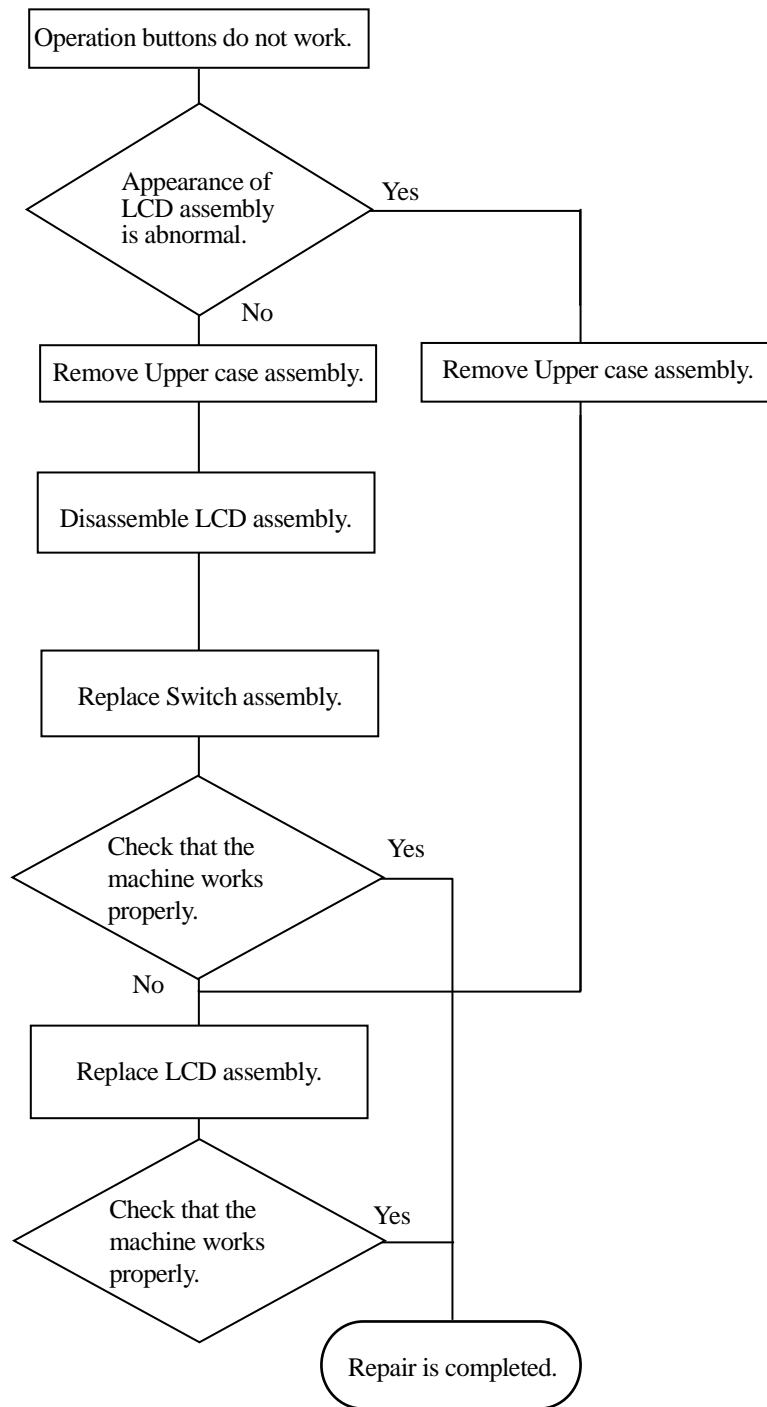

7-4 Laser/ Light does not light up.

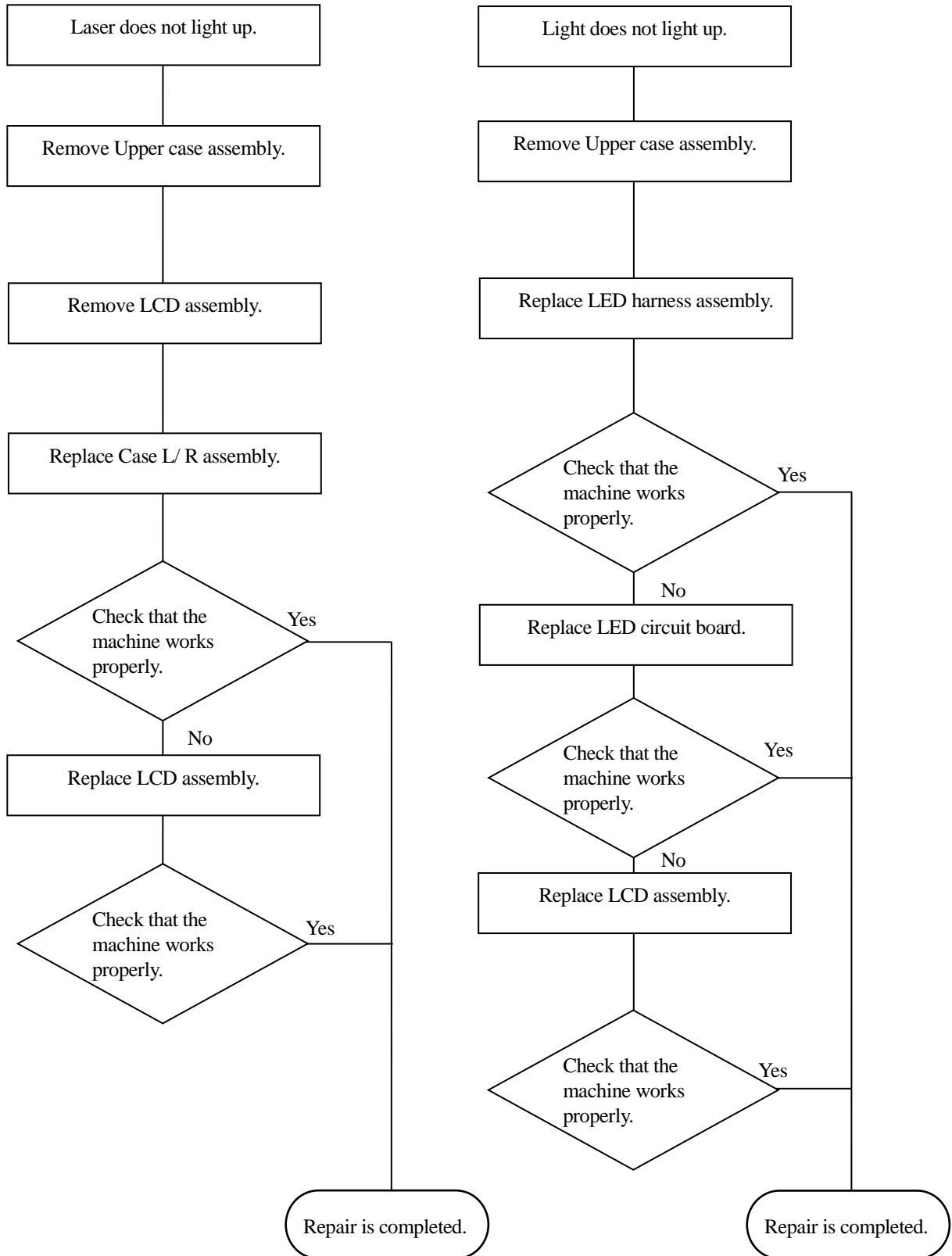

7-5 Detection results do not appear.

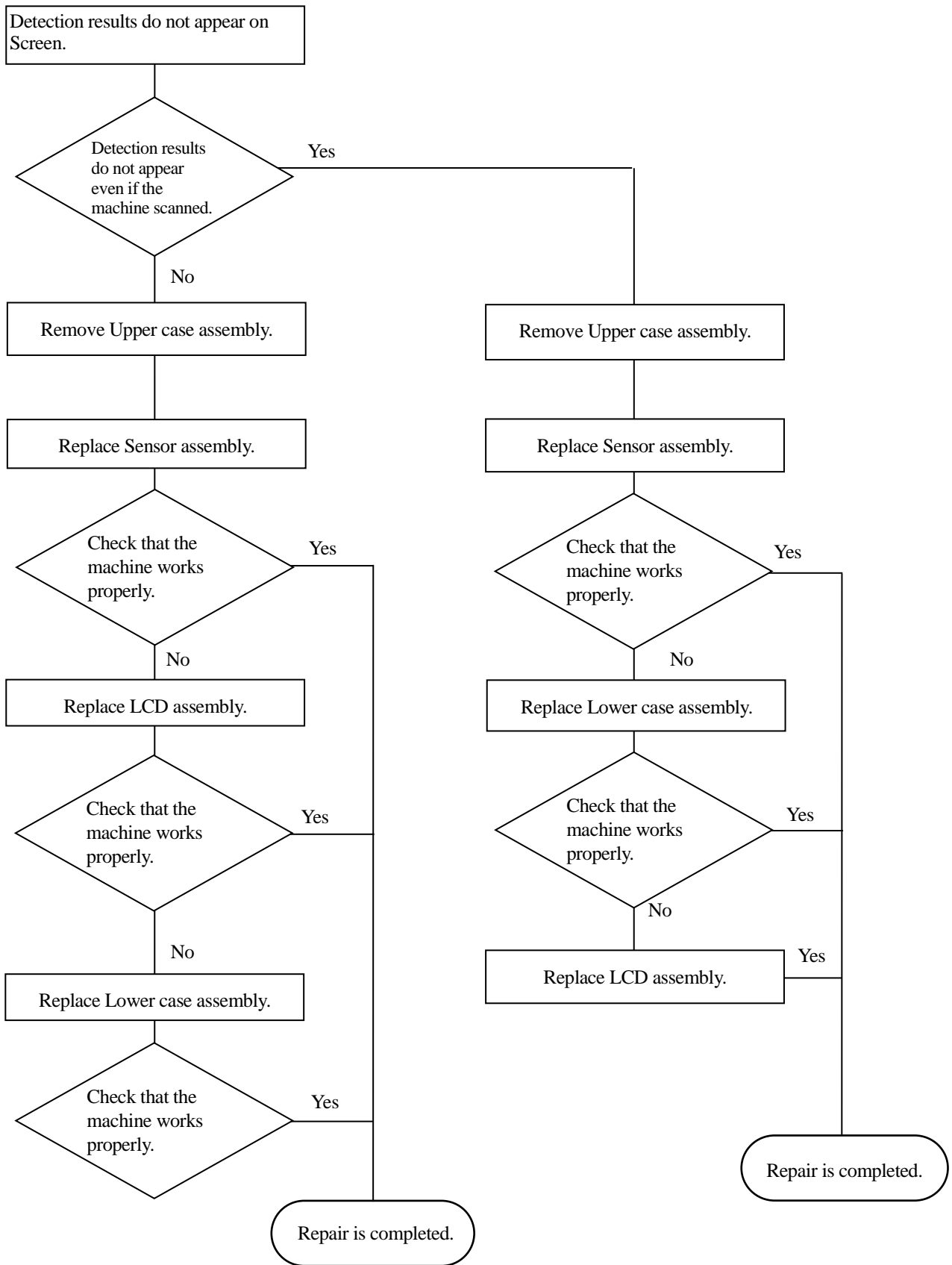

7-6 Wheels worn out.

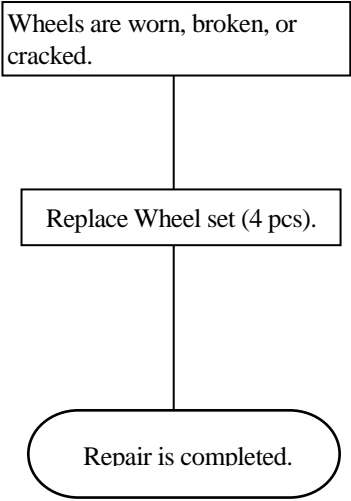

8 REPAIR

8-1 Upper/ Lower case section

8-1-1 Upper case assembly/ Disassembling

Fig.3

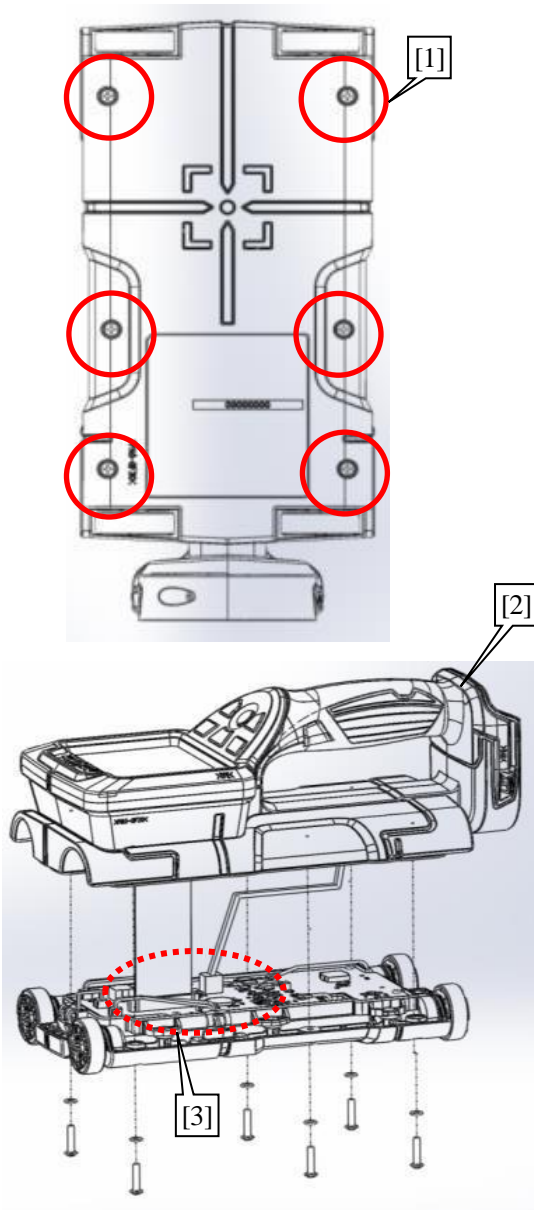

- 1 Remove Tapping screws M3x16 [1] (6 pcs), then lift up Upper case assembly [2] slowly.

Note

Be careful not to lift up Upper case assembly [2] forcefully. The forceful lifting would pull Harness.

- 2 After the following steps, Upper case assembly [2] can be removed. (Refer [Fig.4](#) and [Fig.5](#))

The drawings on the left below shows the insertion/removal parts of FFC and the connectors of Terminal assembly [3].

Fig.4



- 3 Disconnect Connector of Terminal assembly from Sensor assembly by hand.

Fig.5

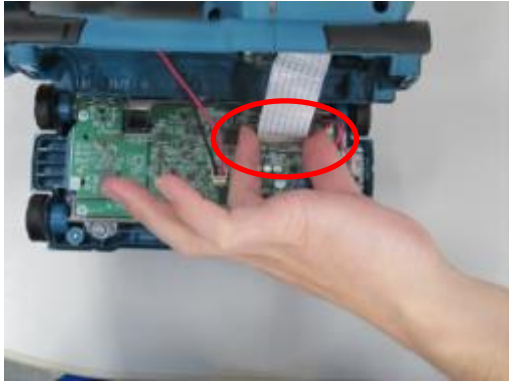

- 4 Remove the lock mechanism section of Connector of FFC, then separate Upper case assembly.

Refer to step 2 of [8-2-1](#).

Note

Be careful to separate Upper case assembly so that no tension is applied to Terminal assembly of Harness and FFC.

8-1-2 Lower case assembly/ Replacement, Assembling

Fig.6

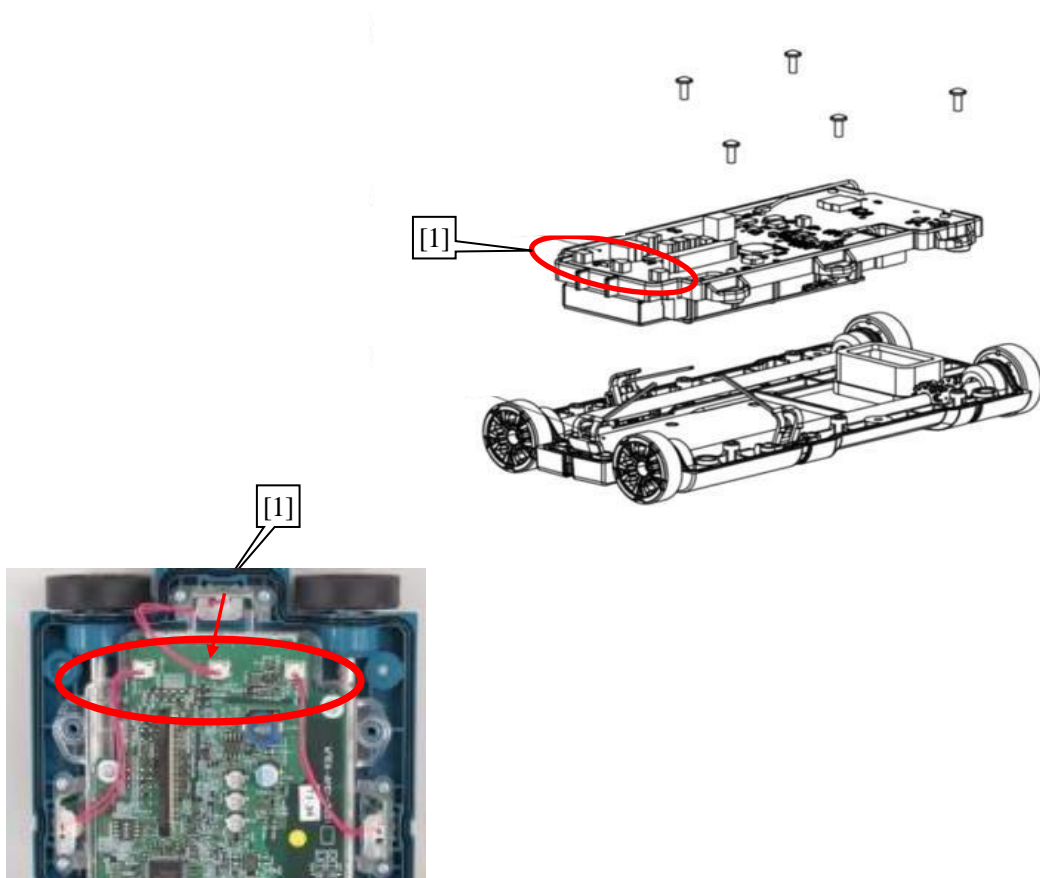

- 1 Disconnect Connectors of Harness set/ LED [1] (3 positions) from Sensor assembly.
- 2 Remove Tapping screws 3x8 (6 pcs) from Sensor assembly.
- 3 Lift up and remove Sensor assembly.

Note

If Sensor assembly is not damaged, store it in a static-safe place.

- 4 Replace Lower case assembly, then assemble Sensor assembly.
- 5 Tighten Tapping screws 3x8 (6 pcs).
- 6 Connect Connectors of Harness set/ LED (3 positions).

8-2 FFC section
8-2-1 Disassembling

- 1** Remove LCD assembly. ([8-4-1](#))
-

Fig.7



- 2** Lift up both sides of the lock portion (Black) of Connector of FFC.
-

Fig.8



- 3** Pull FFC straight.
-

8-2-2 Assembling

- 1** Assemble FFC. ([8-6-2](#))
-

8-3 Upper case assembly
8-3-1 Assembling

Fig.9

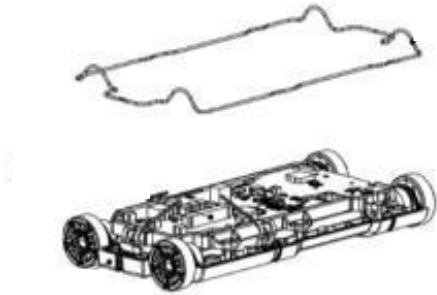

- 1 Assemble the new Packing D to Lower case assembly.

Note

Be careful to assemble Packing D so that its orientation should be fit with the shape of the groove.

Fig.10



- 2 Position Upper case assembly and Lower case assembly as shown.

Fig.11

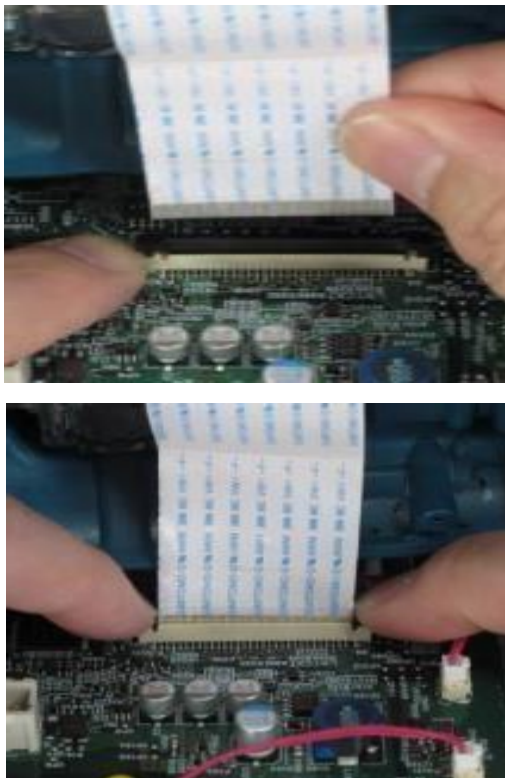

- 3 Connect FFC to Sensor assembly. (Refer [8-6-2](#))

Fig.12



- 4 Connect Connector of Terminal assembly to Sensor assembly.

Fig.13



- 5 Assemble Upper case assembly to Lower case assembly.

Note

Be careful to assemble them so that Packing D is assemble correctly. If it is assembled incorrectly, the waterproof function will not work.

- 6 Tighten Tapping screws M3x16 (6 pcs) on the bottom of the machine.

8-4 LCD assembly section
8-4-1 Disassembling 1

Fig.14

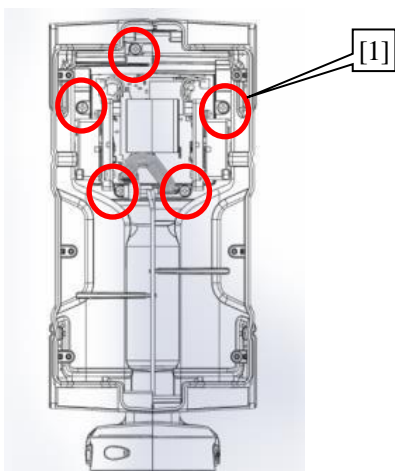

- 1 Remove Tapping screws 3x8 [1] (5 pcs) inside Upper case assembly.

Fig.15



- 2 Slide LCD assembly as shown, then remove Hook of Case L/ R assembly and LCD assembly.

Fig.16

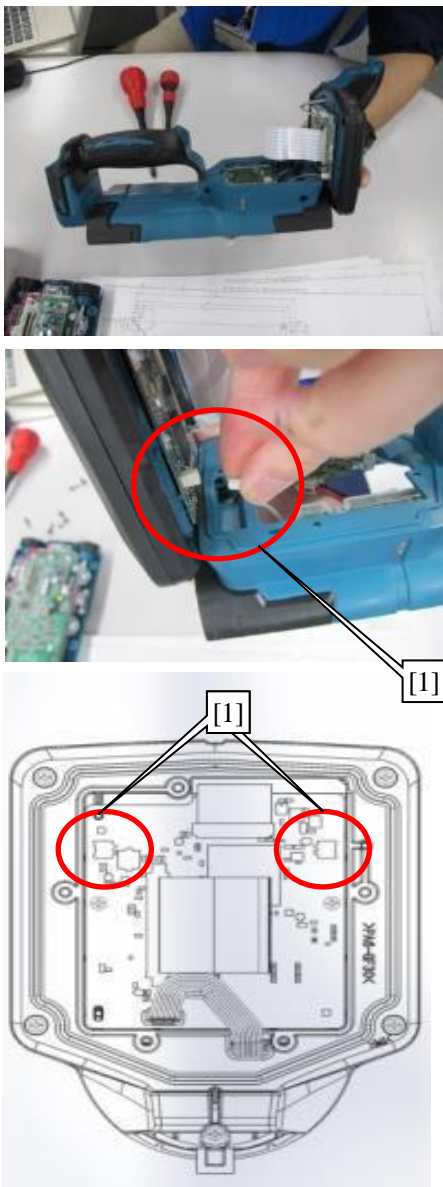

- 3 Stand LCD assembly as shown, then remove Harnesses (2 positions) from LCD assembly.

Note

Be careful not to touch the internal wiring [1] when using the repair tools.

8-4-2 Disassembling 2

Fig.17

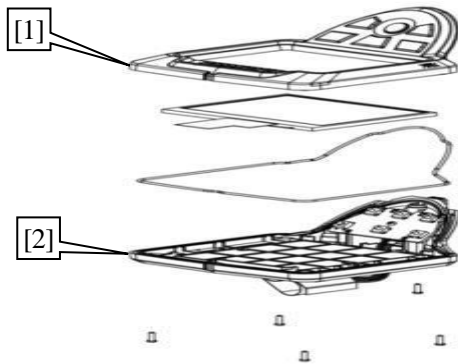

- 1 Remove LCD assembly.

Note

Be careful to separate Upper LCD case [1] and Lower LCD case [2] as shown in direction so as not to drop the parts inside.

Fig.18

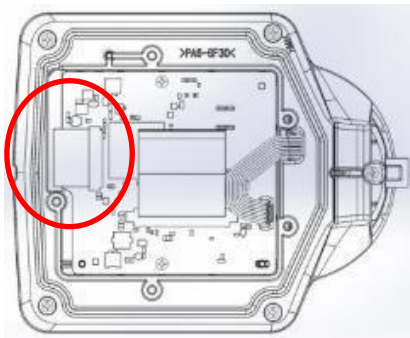

- 2 Release the lock of FCC Connector for LCD in Red circled, then remove FFC from Connector. (Refer [8-6-1](#))

Fig.19

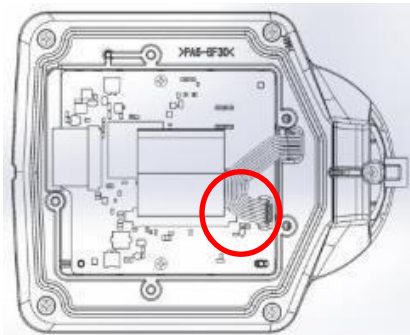

- 3 Remove Harness of Switch assembly in Red circled from LCD assembly.

Fig.20

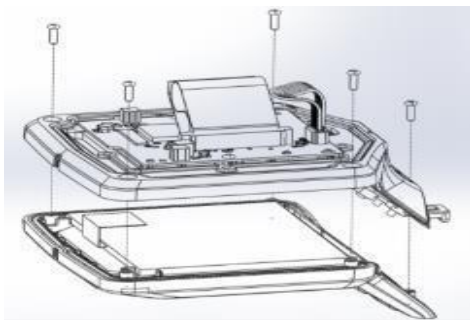

- 4 Remove Tapping screws 2.3x8 (5 pcs) on the back of LCD assembly with a No.1 Phillips screwdriver.

Note

Be careful not to forget to remove Packing A.

8-5 Switch assembly section
8-5-1 Replacing

Fig. 21



- 1 Remove Tapping screw 2.3x8, then remove Switch assembly.

Note

Be careful not to touch the tactile switch on the circuit board of Switch assembly with the screwdriver when removing screw.

Fig.22

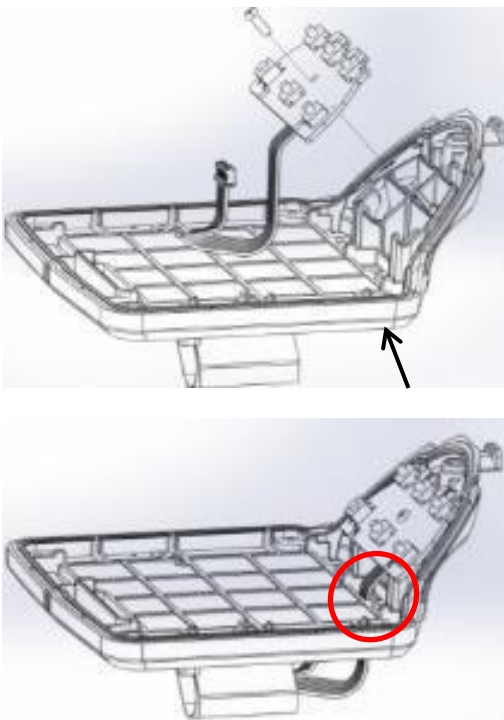

- 2 Assemble new Switch assembly with passing Harness of Switch assembly through the slot, then tighten it with Tapping screw 2.3x8.

8-6 LCD assembly section
8-6-1 Assembling

Fig.23

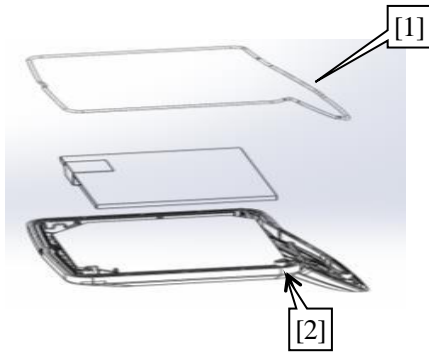

- 1 Check that there is no scrap of the plastic caused by Tapping screws inside LCD screen or Upper and Lower LCD case.
- 2 Assemble Packing A [1] to Upper LCD case [2].

Note
Be careful to assemble Packing so that its orientation should be fit with the shape of the groove.

Fig.24

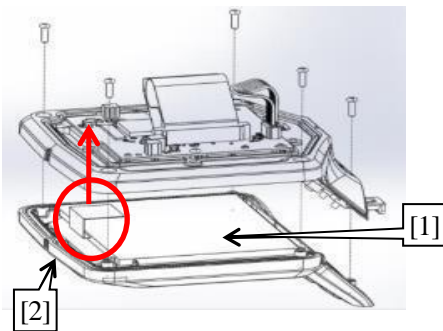

- 3 Assemble Upper LCD case [2], LCD and Lower LCD case.
- 4 Pass Harness of LCD [1] through the hole of Lower LCD case, then route it to the circuit board side.
- 5 Assemble Switch assembly with Tapping screws 2.3x8 (5 pcs).

Fig.25

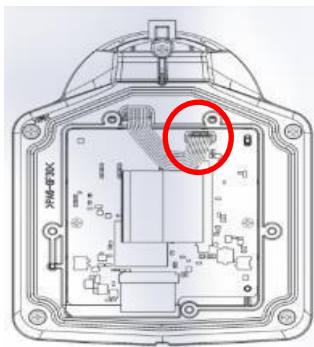

- 6 Connect Harness of Switch assembly to LCD assembly.

Fig.26

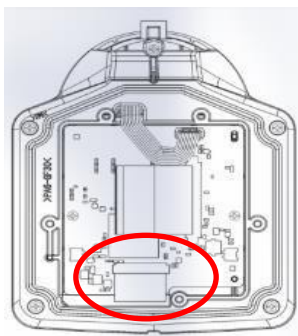

- 7 Connect FFC of LCD to the circuit board of LCD assembly.

Note
<ul style="list-style-type: none"> • FFC should be routed along the inside of Connector and insert it firmly. • Insert FFC straight so that it does not tilt. • Turn the lock of FFC connector firmly.

Fig.27

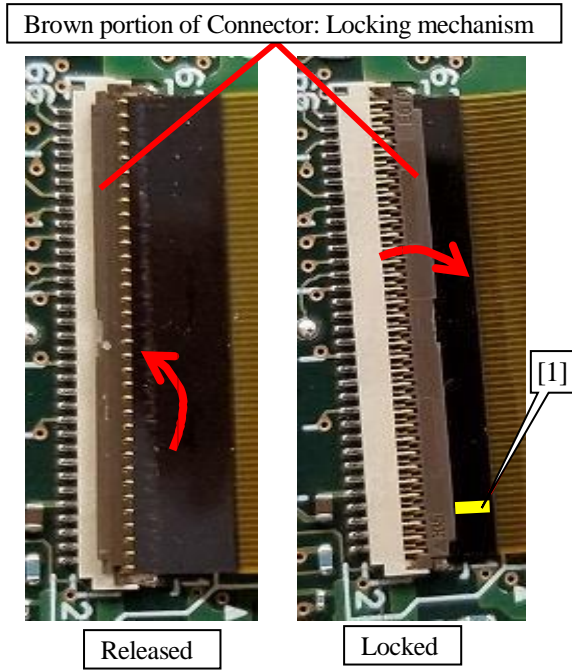

Black film is exposed in approximate 1.35mm when Connector is in locked as shown [1].

Fig.28

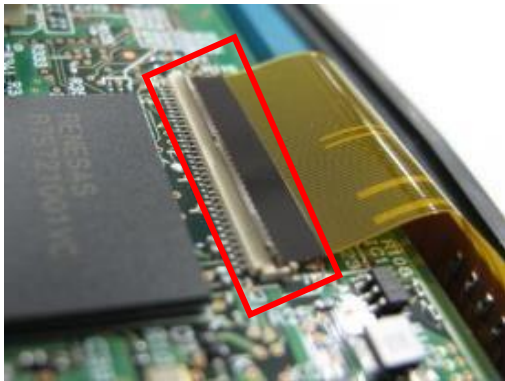

The lock of FFC Connector on LCD is released.

Fig.29



The lock of FFC Connector on LCD is locked.

8-6-2 Replacing

Fig.30

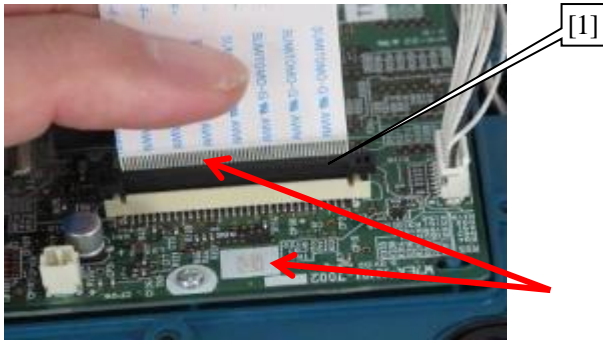

- 1 Check that Black film portion [1] is raised.

Note

Insert so that FFC terminal face is on the data matrix side.

Fig.31

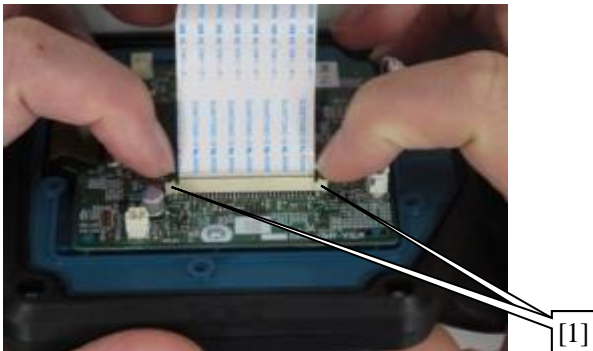

- 2 Connect FFC to the circuit board of LCD assembly.

Note

Make sure that FFC does not remove by pulling it lightly.

- 3 Press both sides of the locking portion [1] evenly.

Fig.32



- 4 Connect Harnesses (2 positions) of Laser before assembling Laser to Case L/ R Assembly.

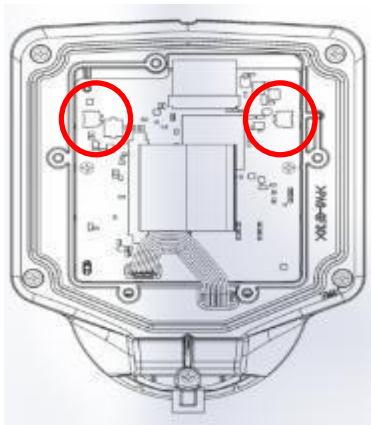
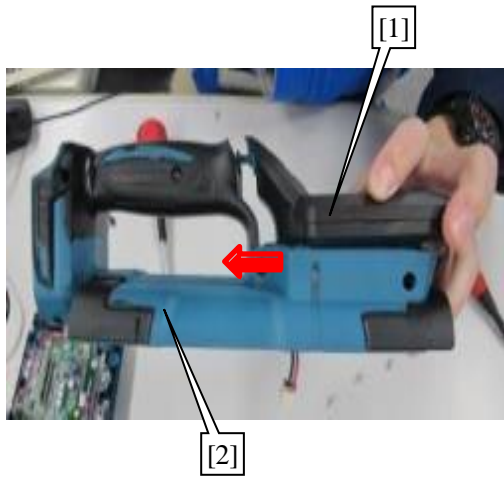
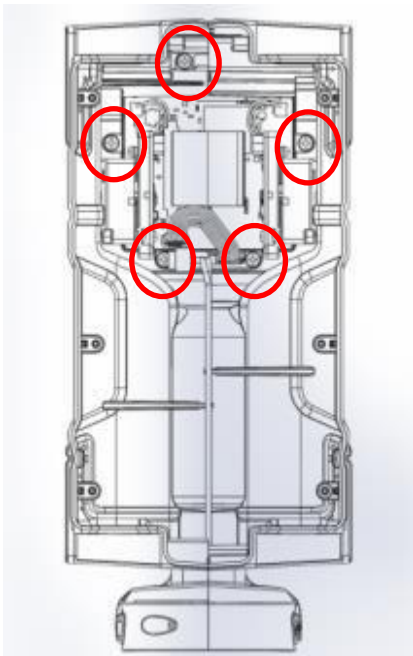

Fig.33



- 5 Mate Case L/ R assembly [2] and LCD assembly [1] carefully to prevent FFC from being caught. Then insert Hook of LCD assembly into Case L/ R assembly as shown.

Fig.34



- 6 Tighten Tapping screws 3x8 (5 pcs) from the inside of the Case L/ R assembly with a No.1 Phillips screwdriver.
- 7 Fasten Case L/ R assembly and LCD assembly so that there is no gap between them.

Note

Be careful not to touch the internal wiring when using the repair tools.

8-7 Sensor assembly section
8-7-1 Removing

Fig.35

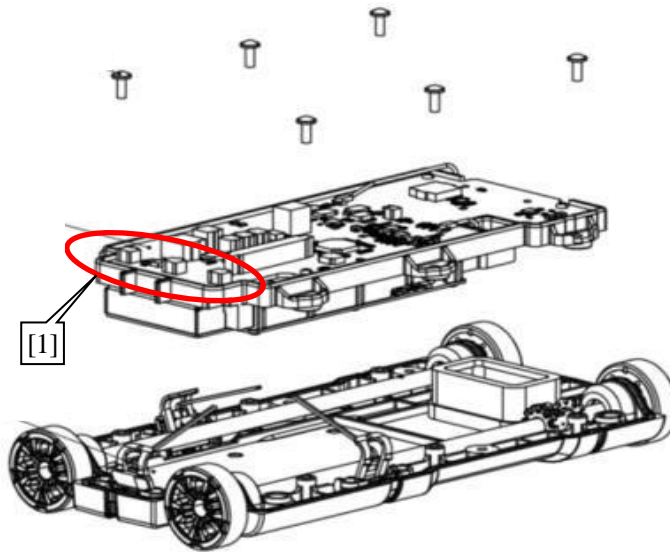

- 1 Remove Harness set/ LED [1] (3 positions) from Sensor assembly.
- 2 Remove Tapping screws 3x8 (6 pcs) from Sensor assembly.
- 3 Lift up and remove Sensor assembly.

Note

If Lower case assembly is not damaged, it can be used for repair.

8-7-2 Replace/ Assembling

- 1 Replace Sensor assembly, then assemble it to Lower case assembly.
 - 2 Tighten Tapping screws 3x8 (6 pcs).
 - 3 Connect Harness set/ LED (3 positions) to Sensor assembly.
-

8-8 Case L/ R assembly section
8-8-1 Disassembling

Fig.36

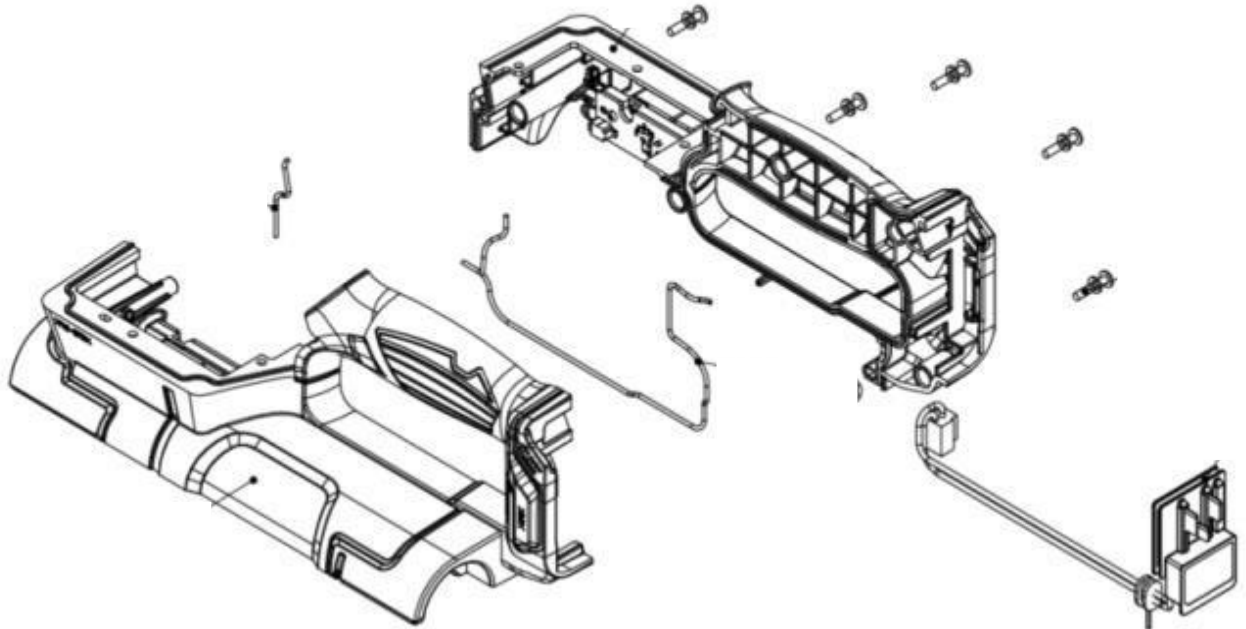

-
- 1** Remove Tapping screws M3x16 (5 pcs).
 - 2** Separate Case L assembly from Case R assembly.
 - 3** Dispose the removed Packing B/ C sets.
-

8-8-2 Assembling

Fig.37

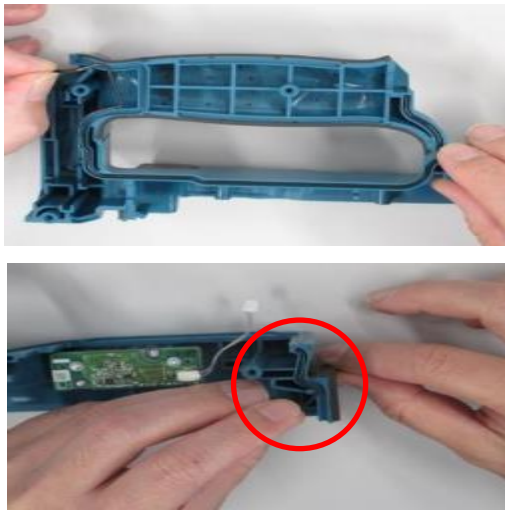

- 1 Assemble Packing B/ C sets (2 positions) to Case L assembly.

Note

The orientation of Packing B/C sets matters. Be careful to fit the shape into the groove of Case L.

Fig.38

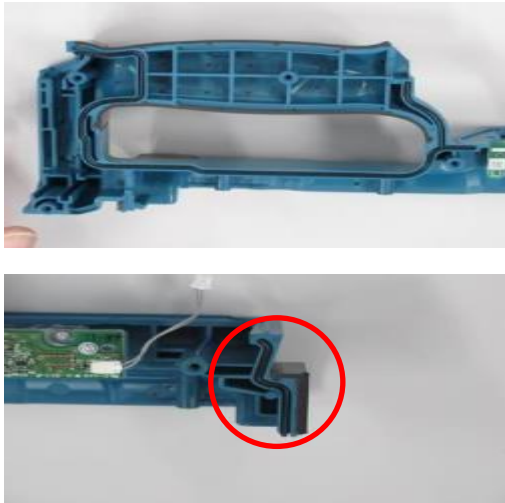

- 2 Place Packing B/ C set so that they should not protrude and to be fit along the groove of Case L assembly.

Fig.39

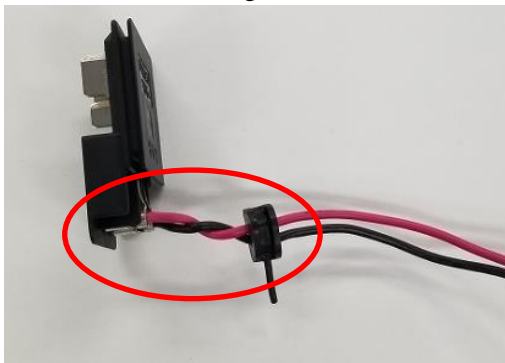

- 3 Wires between Terminal of Terminal assembly to Packing should be twisted by 1.5 times as shown.

Note

Packing may come off from the groove when assembling Case L/ R assembly if the above step is not done.

Fig.40

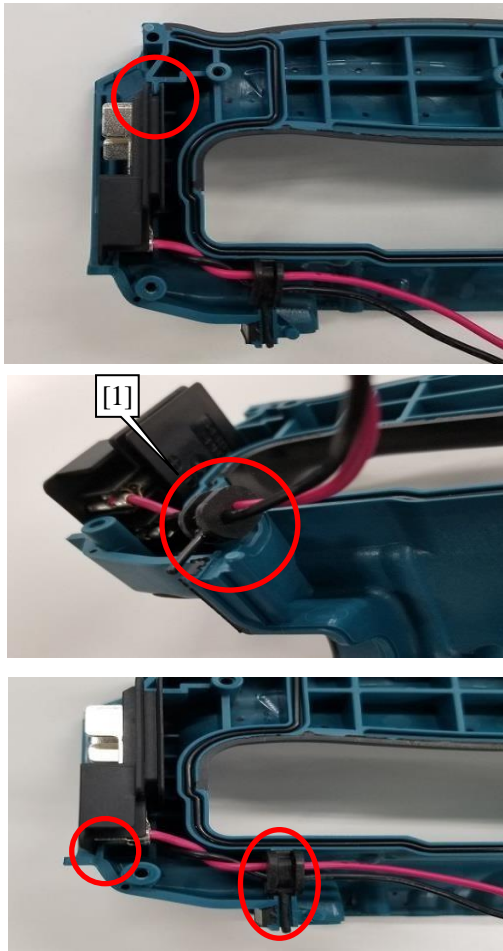

- 4 Assemble Terminal assembly to Case L assembly.
- 5 Place Terminal correctly in the slot.
- 6 Fit Packing [1] for Terminal assembly to the grooved shape of Case.

Note

The orientation of Packing [1] matters.

Fig.41



- 7 Assemble Case R assembly so that Packing B/ C set and Packing of Terminal assembly are not pinched.

Note

Be careful not to drop Packing B/ C set.

- 8 Tighten Tapping screws M3x16 (5 pcs).

Fig.42

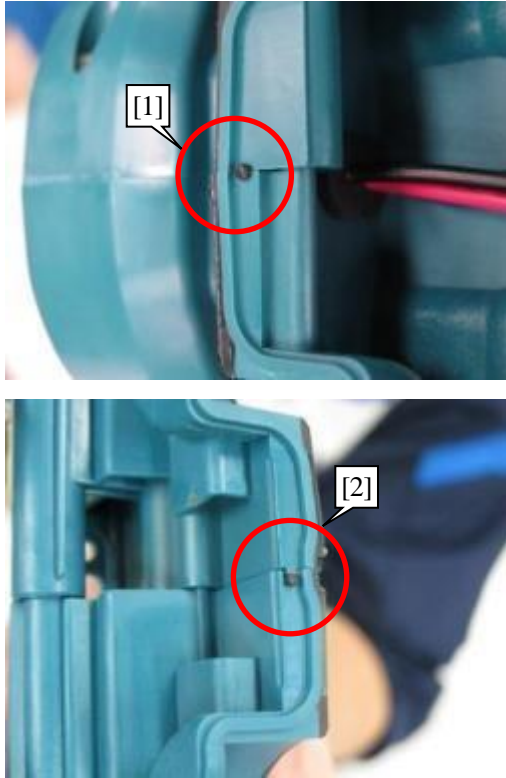

- 9 Check that the part of Packing C [2] and Packing for Terminal assembly [1] protrude from Case L/ R assembly as shown.

Note

If Packings do not protrude, the waterproof function will not work because of the improper position of Packings. In this case, reassemble them.

Fig.43

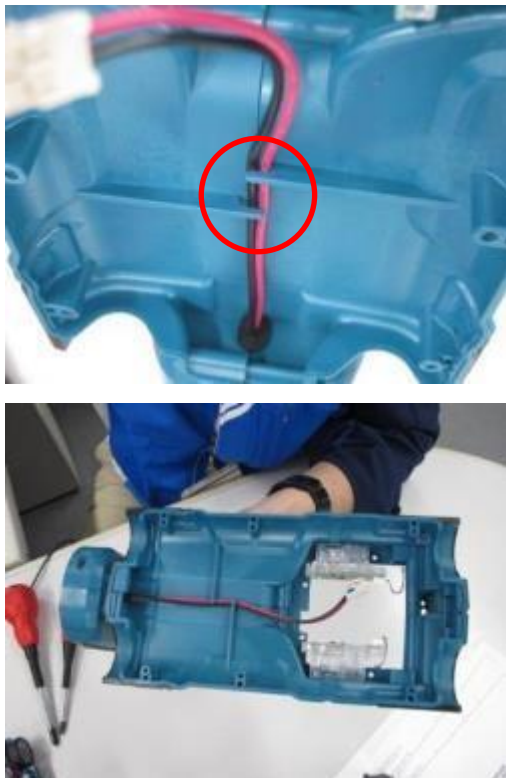

- 10 Fix Harness of Terminal assembly in the hooks in Case.

8-9 PCB/LED section
 8-9-1 Replacing

Fig.44

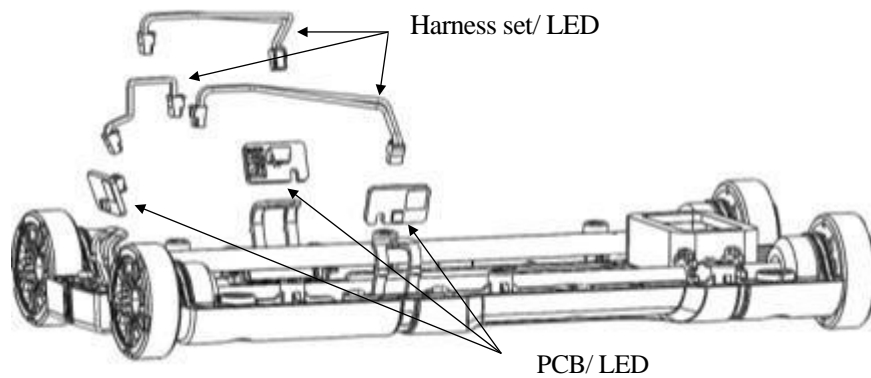
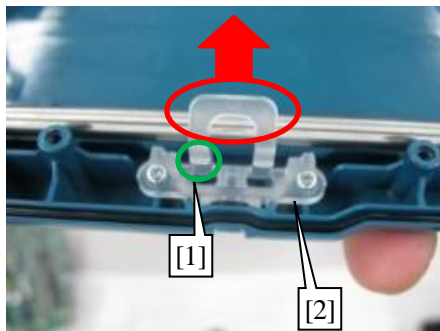

Fig.45



- 1 Remove Harness set/ LED from PCB/ LED.

Fig.46



- 2 Remove PCB/ LED from Lower case assembly.

Tips

Push the tab [1] of LED lens [2] in Red circled in the direction of the arrow lightly and pinch up PCB/ LED.

Fig.47



- 3 Connect new PCB/ LED to LED lens of Lower case assembly.

Note

Connect it until it is caught in the rib of Holder for Circuit board.

Tips

Harness can be easily removed with tweezers, etc.

8-10 Harness set/ LED section

8-10-1 Replacing

Fig.48

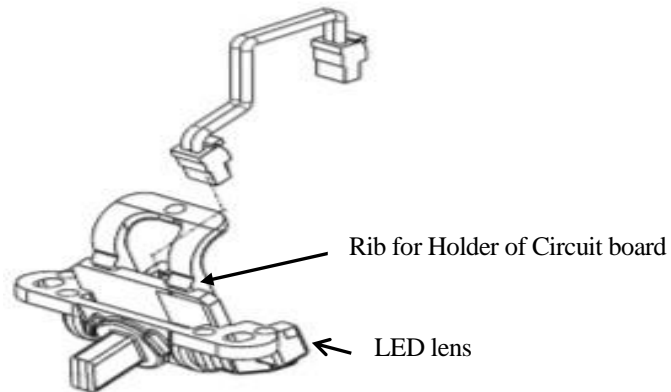

Fig.49



- 1 Connect Harness set/ LED to PCB/ LED connectors.

Note

PCB/ LED should be connected which guided from the inside of LED lens.

8-11 Terminal assembly section

8-11-1 Replacing

- 1 Replace Terminal assembly. (Refer [8-8-2](#))

8-12 Wheel set section
8-12-1 Replacing

Fig.50

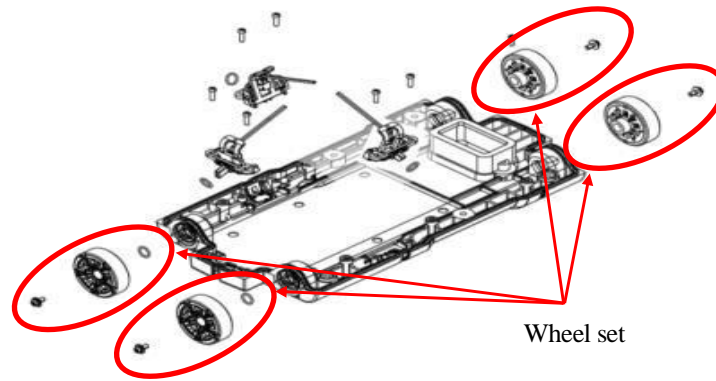

Fig.51



- 1 While holding Wheel firmly to prevent it from turning, remove Screw M2.5x6 with a No.1 Phillips screwdriver.

Note

Do not forget to remove O ring after removing Wheels.

Fig.52



- 2 Assemble O rings of Wheel set (4 pcs).

Note

Be sure to assemble it fully in contact with Bearing.

Fig.53

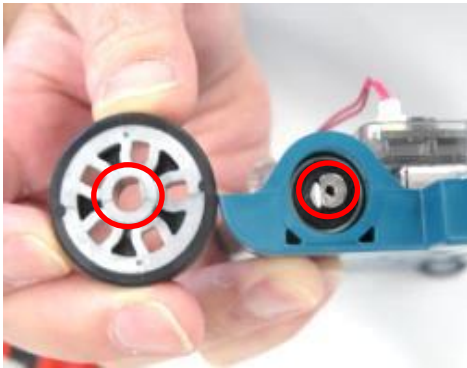

- 3 Align the shape of Wheel and Shaft, then assemble them.

- 4 Fasten Wheel to Shaft with Screw M2.5x6.
- 5 Similarly, replace the other three Wheels.

Fig.54

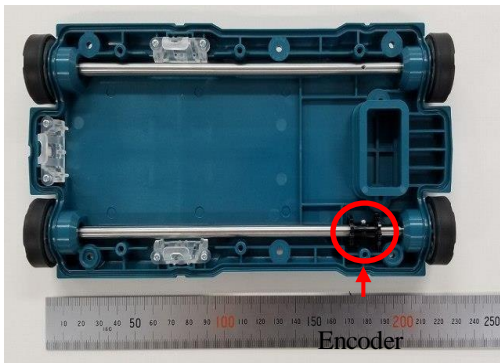

Note

- When removing Wheel of the shaft with Encoder or after removing it, handle it so that the shaft with Encoder is not moved as much as possible.
- The shaft with encoder cannot be removed by only removing Wheel. If an external force is applied more than necessary, Encoder and the other area may damage.

9 PROPER OPERATION CHECK

9-1 Check of Activate operation

Fig.55



- 1 Press the power button.
- 2 Check that starting sound beeps and the startup screen appears.

Fig.56

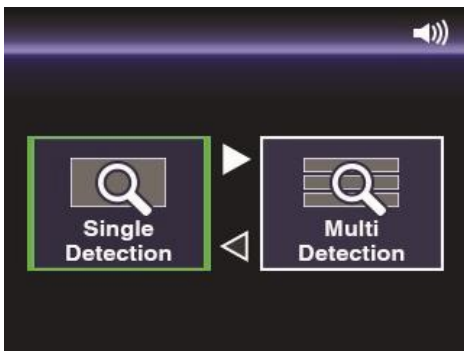

- 3 Check that the screen is automatically switched to "Scan mode selection" after view of [Fig.55](#).

9-2 Check of Button operation

- 1 Check that "Single Detection" and "Multi Detection" can be selected on the "Scan mode selection" screen by pressing Left/ Right button. (The icon of "Single Detection" or "Multi Detection" lights up in green when either is selected.)

Fig.57



- 2 Check that the screen is switched to Scene selection when "Single Detection" mode is selected and Apply button is pressed.

- 3 Check that the four scenes appear in order when Right button is pressed on "DRY Concrete" screen.

Fig.58

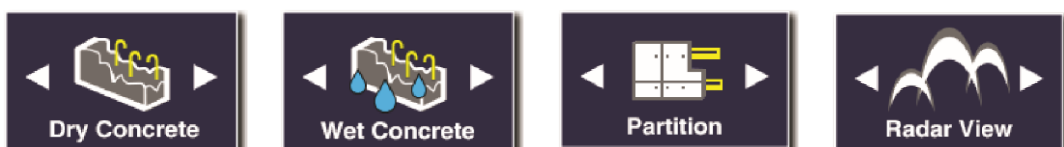
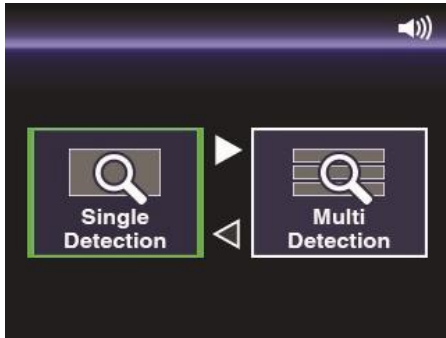
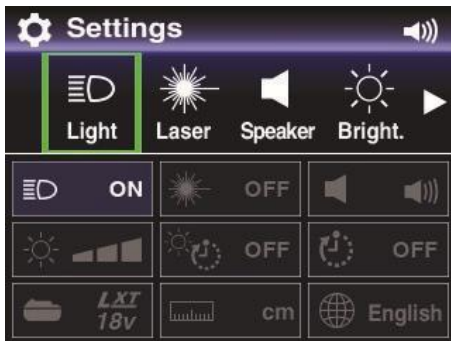

Fig.59



- 4 Check that the screen is switched to “Single detection” mode by pressing Mode button on any screen.

Fig.60



- 5 Check that the screen is switched to “Settings” by pressing Setting button on any screen. (When Setting button is pressed, Light is selected by a green frame.)

9-3 Check of Lighting

Fig.61



- 1 Check that the screen is switched to “Settings change” by pressing Apply button on “Settings” screen.

- 2 Light “ON” or “OFF” can be selected with Left/ Right button.
- 3 “Settings” will be confirmed by pressing Apply button.
- 4 Check that Light turns on properly by selecting "ON", then pressing Apply button.

9-4 Check of Laser lighting

- 1 The bottom of screen changes to “Settings change” when Laser is selected on “Setting” screen and press Apply button.
 - 2 Laser “ON” or “OFF” can be selected with Left/ Right button.
 - 3 “Settings” will be confirmed by pressing Apply button.
 - 4 Check that Laser lights up properly by selecting "ON" then pressing Apply button.
-

9-5 Check of Detection result image

- 1 Two methods of checking detected images are available. (Refer [Fig.62](#))
-

9-5-1 The method of Confirmation of Detection with using Reference instrument

Fig.62

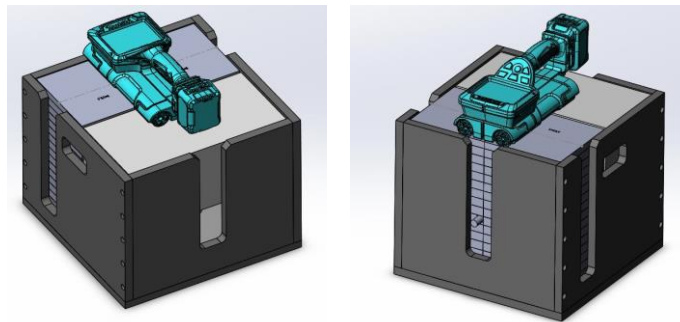

- 1 Set Reference instrument. (Produced with Potassium Titanate Compound)
 - 2 It is a benchmark positioned so that the depth from the top to the center of Iron bar is 16.0cm.
-

Fig.63

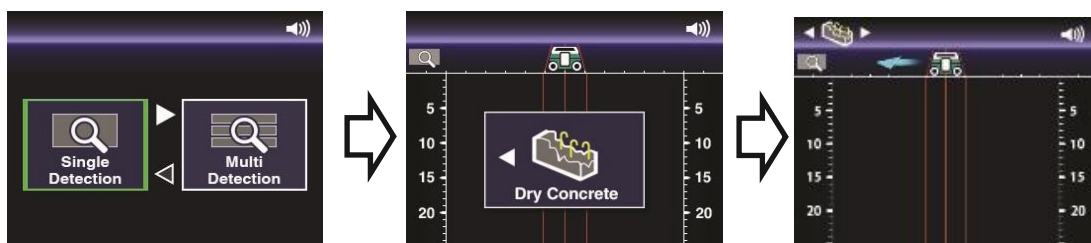

- 3 Select the scene of “Dry Concrete” with “Single Detection” mode, then press Apply button.
 - 4 Position the machine on the top surface of the Reference instrument so that the center line of the machine is parallel to Iron bar, then scan the machine in the direction perpendicular to Iron bar.
-

Fig.64



5 Checking Detection result image

- Check that the detected image is displayed in conjunction with the scanning direction of the machine.
- Check that the result of the detection of Reference instrument shows the top convex shape.
- Make sure that Iron bar is deep in $16.0\text{cm} \pm 1.0\text{cm}$.

9-5-2 The method of Simple confirmation of Detection without using Reference instrument

Fig.65

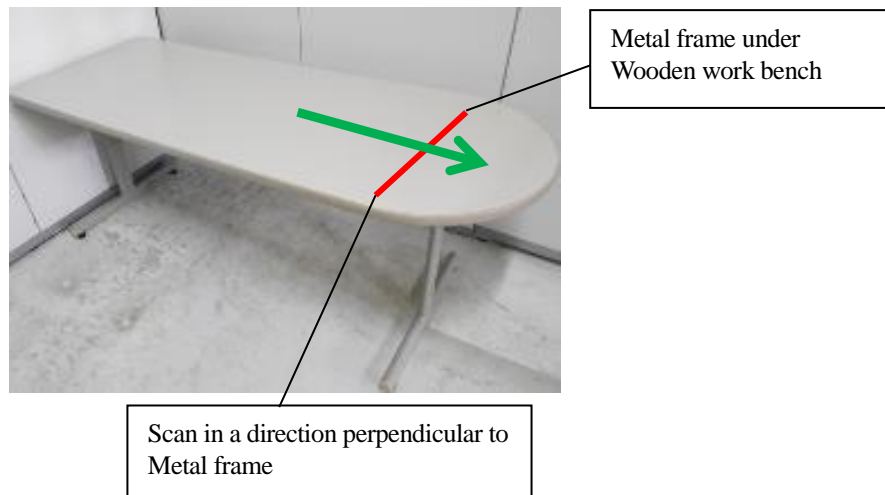

- 1** Prepare a desk with a Metal beam support under Wooden work bench.
- 2** Select the scene of “Dry Concrete” with “Single Detection” mode, then press Apply button.
- 3** Checking Detection result image
 - Scan the machine in the direction perpendicular to Metal frame of work bench.
 - Check that the detected image is displayed in conjunction with the scanning direction of the machine.
 - Check that the result of the detection shows the top convex shape.