



GT622 GARDEN TILLER

Operation, Safety & Maintenance Instructions



Online Demonstration Available at: www.redroo.com/products/rotaryhoe



INTRODUCTION

Dear Valued Customer,

Congratulations! You are now the proud owner of the Red Roo Model GT622 Garden Tiller. Please take a moment of your time to look over the following information Familiarise yourself with the tiller, its characteristics and method of operation. Pay particular attention to the safety and operating instructions.

If you have any questions or need any replacement parts in the future please contact us at your convenience on our toll-free phone number 1300 133 767 or redroo.com

*THANK YOU for your patronage, confidence and support in
Red Roo commercial environmental equipment.*

Machine Identification Record

Red Roo Customer number _____

Machine model number _____

Machine serial number _____

Engine manufacturer _____

Engine model number _____

Engine serial number _____



Table of Contents

ASSEMBLY INSTRUCTIONS	3
ABOUT THIS MANUAL	4
SAFETY INSTRUCTIONS	5
OPERATING INSTRUCTIONS	6
SERVICE INFORMATION	7
HOUR METER	7
HONDA GX160 SCHEMATIC	8
HYDRAULIC SCHEMATIC	8
ROBIN EX17 SCHEMATIC	9
SPECIFICATIONS	10
ENGINE CONTROLS	11
TROUBLESHOOTING	12
WORKSITE ASSESSMENT	13
GT622 ASSEMBLY ILLUSTRATIONS	14
RED ROO WARRANTY	18

ASSEMBLY INSTRUCTIONS

1. Remove the tiller from shipping crate. Please inspect immediately for any damage and notify the shipping company and Red Roo, right away if any is found.
2. Check reservoir according to instructions in service information on the following page.
3. Fill the engine with fuel and oil according to the engine manual.
4. When documentation refers to “right side” or “left side”, it is relative to the operator’s position with both hands on the handlebars.

RED ROO SALES & SERVICE COMPANY PTY. LTD.

41-43 Keysborough Avenue, Keysborough, Victoria, Australia 3173

Tel.: +61 (03) 9769 0455 Fax: +61 (03) 9769 0366

Outside Melbourne Metro: Tel.: 1300 133 767 Fax: 1300 133 757

redroo.com

ABOUT THIS MANUAL

The information contained in this manual has been prepared to assist you in the safe operation, the routine maintenance and general care of your Red Roo product. By following these guidelines, you may look forward to years of reliable service from your Red Roo. Information is categorised and denoted by the following symbols and phrases:



SAFETY FIRST Identifies general safety practices.













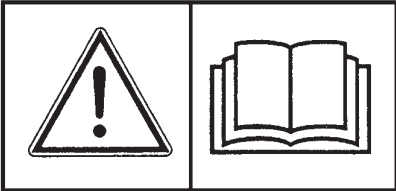





DANGER! An instruction which, if not followed, could result in serious or fatal injury.



WARNING! An instruction which, if not followed, could result in personal injury.



CAUTION! An instruction which, if not followed, could damage machine components.

	<h2>HAZARD SYMBOLS & MEANINGS</h2>				
<p>Before operating this Machine read and observe all Warnings, Cautions and Instructions on the Machine and in the Operators Manual. Although the reading of information contained in this manual does not eliminate the risk involved in operating this machine, your understanding of this information will promote the correct and safe use of your machine. Failure to follow Instructions and Safety Information could result in serious injury or death.</p>	 Read	 Hearing Protection	 Eye Protection	 Wear Gloves	 Cut Hand
	 Electrical Shock	 Moving Parts	 Hot Surfaces	 Remove Spark Plug Leads	 Toxic Fumes
	 No Bystanders	 Don't Remove Guards	 Explosion	 Don't Refuel Hot Engine	 Keep Clear Rotating Tyres

SAFETY FIRST – Stay Alert, Do Not Get Hurt



Read this section before use!

The GT622 Garden Tiller is designed to cultivate soil and therefore is potentially dangerous. Careless or improper use may result in serious or even fatal injury.

It is important that you read and understand the contents of this manual and that you allow only mature, adult individuals to operate your Garden Tiller. It is your responsibility to ensure that any individual who operates your garden tiller has read and understood this manual.

Never use the garden tiller for any other purpose than soil cultivation. The machine is designed for this purpose only. Any other use may result in serious or even fatal injury and/or damage to the machine.

SAFETY PRECAUTIONS FOR GT622 USERS

Outdoor Power Equipment Institute Recommendations



















WARNING TO PURCHASERS OF INTERNAL COMBUSTION ENGINE EQUIPPED MACHINERY OR DEVICES:

The equipment which you have purchased does not have a spark arrester muffler. If this equipment is to be used on any forest and brush covered land or grass covered unimproved land, the law may require that a spark arrester muffler be installed and be in effective working order. The spark arrester must be attached to the exhaust system and comply with local authorities by-laws.







USE COMMON SENSE AND PLENTY OF IT



- 1)  **DO NOT** allow any person to operate the garden tiller without first reading and understanding the safety precautions and operating instructions. Read and understand the engine manual. **KNOW THE CONTROLS AND HOW TO STOP THE GARDEN TILLER QUICKLY IN AN EMERGENCY.**
- 2) **NEVER** allow children or untrained adults to operate the garden tiller.
- 3) **ALWAYS** wear protective clothing when operating the garden tiller. This includes, but is not limited to: safety glasses, loose fitting gloves, steel capped boots and hearing protection. **NEVER** wear loose fitting clothing or jewellery when operating the garden tiller. Keep all clothing away from moving parts. Items could become caught in the machine, resulting in injury.   
- 4) **ALWAYS** operate the garden tiller in a well lighted area.
- 5) **ALWAYS** make certain that the tyne engagement control lever is in the "neutral" position prior to starting the engine. The TYNE ENGAGEMENT CONTROL LEVER on the left handlebar is for the operator's protection. All motion stops when the control lever's released!
DO NOT TAPE THE CONTROL LEVER UP or otherwise by-pass this safety feature!
- 6)   **ALWAYS** operate garden tiller on level ground only. Police the area before garden tilling. Remove any foreign objects in the digging area (eg bricks, rocks, wire and sticks). Locate and mark any sprinkler heads, water pipes, gas lines, electrical and telephone cables or any other hazard either below or above ground.
- 7)  **DO NOT** allow other persons near the garden tiller. It is the responsibility of the operator to keep bystanders and animals a minimum of 6 metres (18ft) away from the machine while it is in operation.
- 8)  Hydraulic oil is under extreme pressure and can get under skin and burn or poison. Check for leaks with cardboard.
- 9) **NEVER** operate the garden tiller when fatigued. **ALWAYS BE ALERT!** If you become tired while operating the garden tiller, take a break. If you have any physical or mental condition that may be aggravated by strenuous work, consult your physician before you operate this equipment. **NEVER** operate the garden tiller under the influence of medication, alcohol or drugs.
- 10)   **ALWAYS KEEP YOUR HANDS, FEET AND BODY AWAY FROM THE DIGGING AREA WHILE ENGINE IS RUNNING.**
- 11)  **NEVER** operate the unit without the safety guards in place and in working order. Keep the unit well maintained and in good working order
- 12) **DO NOT** leave the machine unattended while the engine is running.
- 13) **DO NOT** overspeed the engine or alter the governor settings. Excessive speed is dangerous and will shorten engine life.
- 14)  **NEVER** operate the garden tiller in an enclosed area. Engine exhaust contains carbon monoxide, an odourless and tasteless poison.
- 15)  **STOP** the engine, disconnect the spark plug lead and allow engine to cool before inspecting or performing maintenance on the garden tiller.
- 16)  **REFUELLING**
 - * **SHUT OFF ENGINE. DO NOT REFUEL AN ENGINE WHILE OPERATING!**
 - * Allow engine to cool. Minimum 5 minutes.
 - * **USE UNLEADED FUEL ONLY. Use clean, fresh unleaded fuel.**
 - * **Do not mix oil with unleaded fuel.**
 - * Do not over-fill fuel tank. Allow space for fuel expansion.
 - * Do not smoke near equipment.
 - * Allow no naked flame or hot material in refuelling area.
 - * Use only approved fuel containers and funnels. Remember, fuel is a potential hazard.
 - * Refer to engine owners manual for full details.

OPERATING INSTRUCTIONS - GT622

BEFORE USE

- 1) Ensure that all grass and weeds have been cut as low as possible.
- 2) If the garden tiller is to be used in clay or hard ground conditions, it is recommended to water the area thoroughly and allow sufficient time for the soil to soften.
- 3)   Police the area. Remove any foreign objects from the area.
- 4)   Identify and mark the location of sprinkler heads, gas pipes, telephone cables, etc.

OPERATION

- 1) Remove the garden tiller from its trailer/carrier/ute. **Use caution.** 
- 2) Familiarize yourself with the machine and its controls.
- 3) Adjust wheels if required, using the handle wheel adjustment lever.
- 4) Adjust depth shoe if required, using the depth control adjustment lever.
- 5) Ensure the tyne engagement control lever is in the neutral position. The tyne engagement control lever is located on the left hand side of the machine below handle bar. The neutral position of the lever is achieved by simply releasing the tyne engagement control lever.
- 6)  Open fuel shut-off valve. Set choke control to Choke or Start position. Set throttle control to Run or Fast position. Set engine stop switch to On or Run position. Pull starter cord rapidly. Repeat (if necessary) with choke off.
- 7) When in position to begin garden tilling, pull up on the tyne engagement control lever. The tynes will begin to turn, adjust accordingly in the rear position while tilling. Release the tyne engagement control lever to stop the tynes turning. Tyne speed is governed by engine throttle setting.
- 8) Do not hurry the job. Proceed slowly and allow the machine time to do the job. When ground is extremely hard, reduce engine speed. Consider watering the surface and reducing engine speed. Adjust wheels and depth shoe accordingly while tilling.

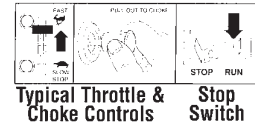

WARNING! – KEEP HANDS AND FEET CLEAR OF TYNES AT ALL TIMES!





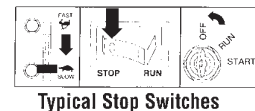

WARNING! – IN CASE OF DIFFICULTY, RELEASE THE TYNE ENGAGEMENT CONTROL LEVER ALL TILLING ACTION STOPS. Turn the engine "STOP" switch to off located on the engine.

- 9) **Stop Engine:** Release the safety clutch control lever. Move throttle to Slow position. Set engine stop switch to Stop or Off position. **DO NOT** move choke control to Choke or Start position to stop engine. Backfire or engine damage may occur.



AFTER USE

- 1)   Turn fuel shut off valve to the "OFF" position.
- 2)   Allow machine to cool down.
- 3) Wash mud and dirt off of the garden tiller. Ensure no water enters the carburettor.
- 4) Remove any weeds, wire, rope or other material that may have wrapped around the tynes and rotor assembly.
- 5) Return wheel axle to forward position for transport. Replace shaft locking collar.
- 6) Return depth shoe (if equipped) to full Up position.

SERVICE INFORMATION

1. Check the reservoir level using the sight glass on the top of the tank. If required, add to reservoir with tractor transmission hydraulic oil (AW or ISO rating of 68 is recommended). Recheck oil level after the tiller has been run and oil has been circulated through the tine motor. Routinely check level thereafter. **DO NOT OVERFILL THE TANK.**
2. Change the hydraulic oil filter after the first 50 hours of use. Change it after every 200 hours thereafter.
3. Check the tine bolts after each use and tighten as needed. Check all hydraulic fittings for leaks and tighten if necessary.
4. Tines should be changed as often as needed for the machine to do a satisfactory and efficient tilling job. Use Loctite stud and bearing adhesive/sealant on tine bolt threads to prevent loosening.
5. The grease zerk on the end of the tine frame should be greased after every 4 to 8 hours of use.
6. The grease zerks on the wheels should be greased monthly.

IMPORTANT: The engine is normally serviced prior to shipping. However, shipping regulations may prohibit this. Check levels and add oil and fuel as required before starting. Service according to the engine manual before starting.

WARNING: Running the tiller without hydraulic oil will cause serious damage to the hydraulic pump. **CHECK RESERVOIR LEVEL BEFORE STARTING THE MACHINE.**

HOUR METER

The SenDEC® TACH/HOUR hour meter tracks the hours of machine operation in order for routine maintenance to be performed on a timely basis.

Your SenDEC® hour meter is preset at the SenDEC® factory to go into *Flash Alert* mode at 25-hour intervals. Although the engine manufacturer does not require changing engine oil this often, **due to heavy-duty use and extreme conditions inherent to tiller use, Red Roo strongly recommends frequent oil changes.**

Refer to this manual for equipment service requirements and to the *Engine Manual* for engine service requirements.

While *Flash Alert* is active, hold the tip of the RESET TOOL (Key Cancel Wand) against the meter as shown. Within several seconds, the display will stop flashing indicating the Service Interval has been reset. If the wand gets lost, a small mechanic's pick-up magnet will work.

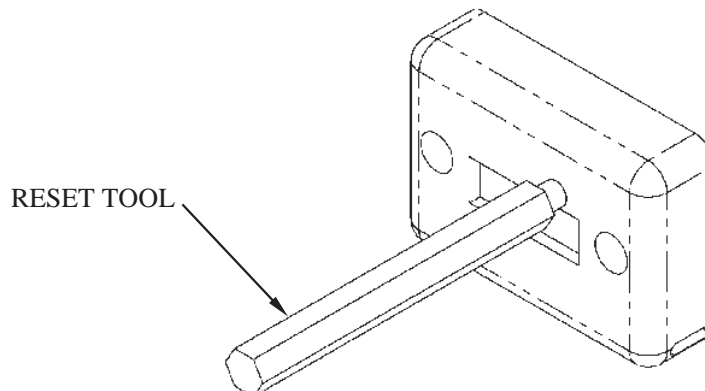

ELECTRICAL SCHEMATIC - HONDA GX160

<Type without electric starter>

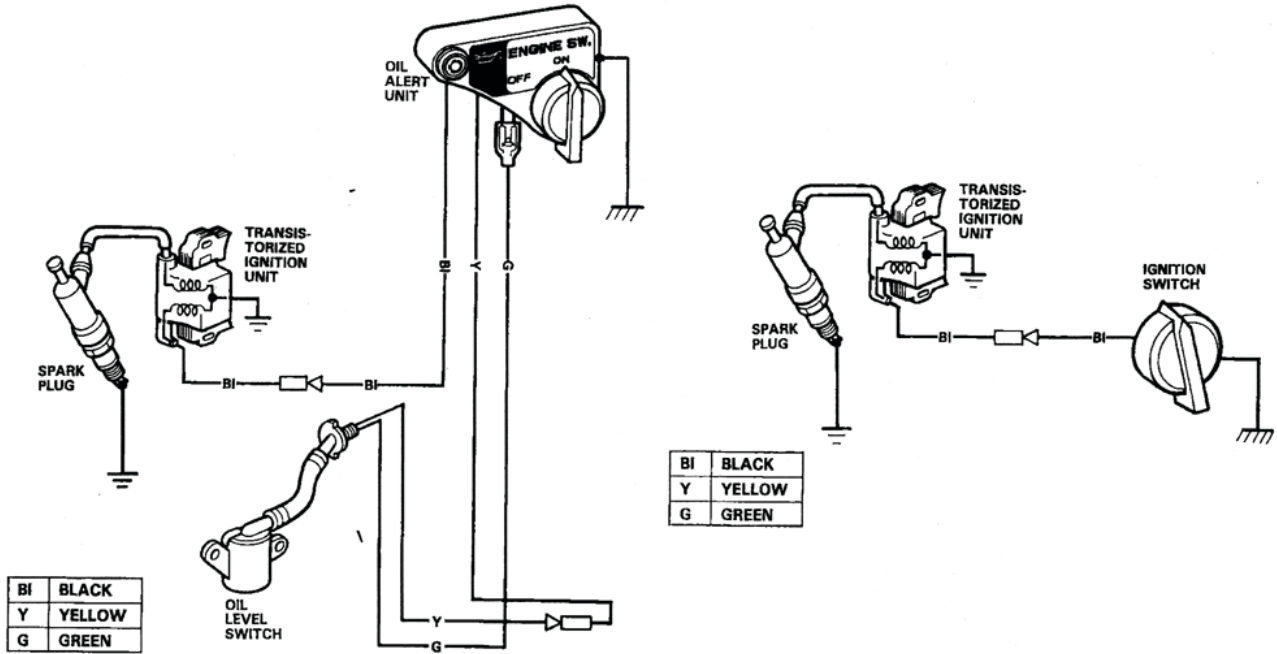

NOTE: Wiring diagrams may vary according to the types.

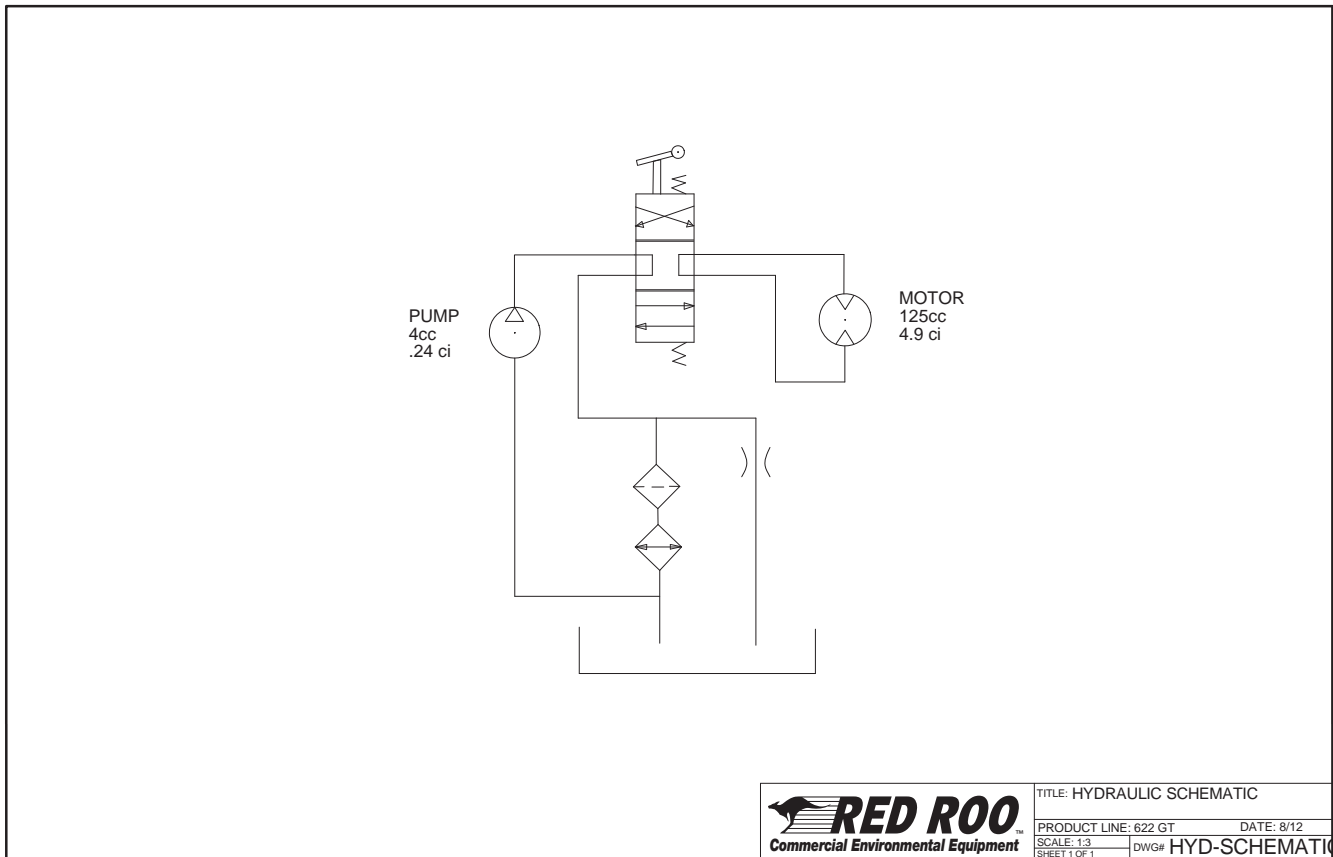

ELECTRICAL SCHEMATIC - ROBIN EX17D

8. WIRING DIAGRAM

8-1 MODEL WITHOUT ELECTRIC STARTER (Models EX13, 17, 21 and 27)

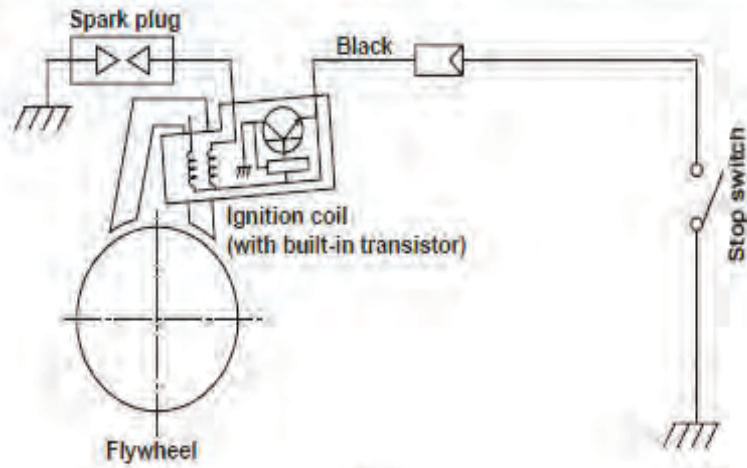
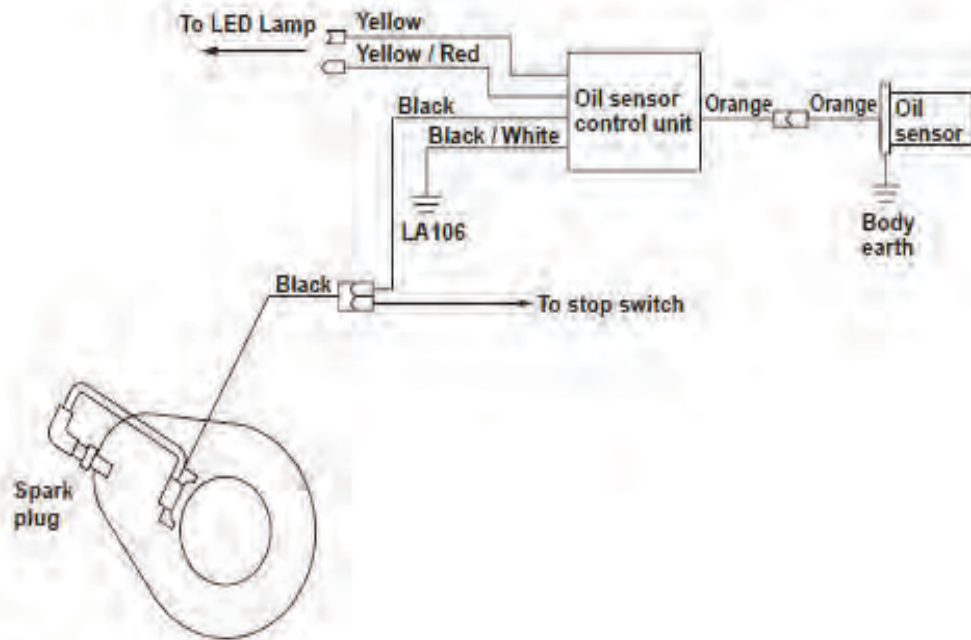

Fig. 8-1

8-4 MODEL WITH OIL SENSOR



GT622 SPECIFICATIONS

MODEL NUMBER

622GT

DIMENSIONS

Weight
Height
Length
Width

211 lbs. (95.7kg)
50" (1.27m)
59" (1.5m)
28" (71.12cm)

ENGINE

Engine
Optional engine

Honda GX160
Robin EX 17D

FUEL

Gasoline

POWER: hp (kW) at 3600 RPM

H-5.5 hp (4.0kW)

POWER: hp (kW) at 4000 RPM

R-5.7 hp (4.2kW)

FUEL CAPACITY

H-0.95 U.S. gallons (3.6 liters)

R-0.94 U.S. gallons (3.6 liters)

ENGINE OIL CAPACITY

H-.63 quart (.60 liters)

R-.63 quart (.60 liters)

HOUR METER

Standard

HYDRAULIC SYSTEM

Reservoir Capacity
Oil Cooler
Hydraulic pump output

1.4 U.S. gallons (5.3liters)

Standard

4 gpm (15.14 liters)

ENGINE CONTROLS

CHOKE: Use to aid starting the engine when it is cold.

IGNITION SWITCH: There are two ignition switches. One switch is located on the control panel for your convenience. The other is located on the engine. Use these to start and stop the engine.

THROTTLE: Use this to adjust engine speed.

GAS SHUT-OFF: Use this when starting or stopping machine.

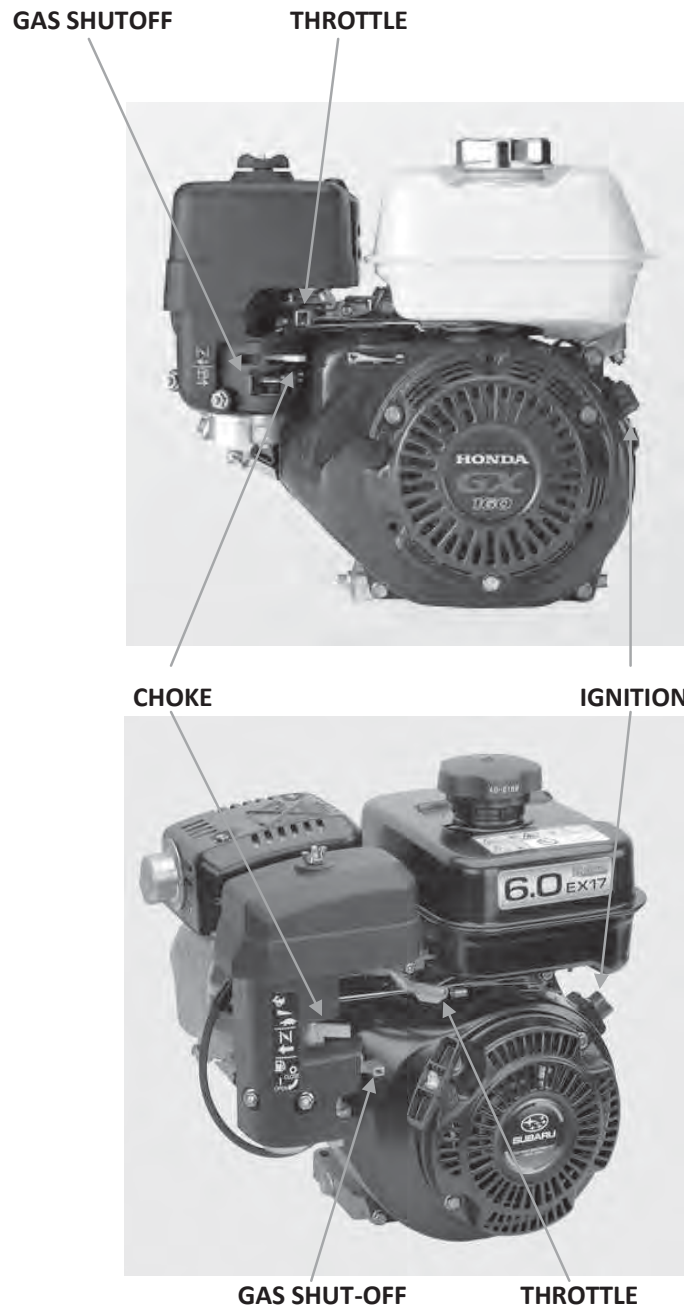

622GT TILLER TROUBLE SHOOTING GUIDE

CAUTION: ALWAYS USE EXTREME CARE WHEN TROUBLE SHOOTING OR MAKING ADJUSTMENTS ON THE TILLER. STAY CLEAR OF TYNES WHEN ENGINE IS RUNNING. ALWAYS SHUT THE ENGINE OFF BEFORE DISASSEMBLING ANY COMPONENT.

A. ENTIRE HYDRAULIC SYSTEM DOESNOT OPERATE AND THE ENGINE IS NOT UNDER LOAD

- | | |
|--|---|
| 1. Low hydraulic oil in tank. | Fill to center of sight glass. |
| 2. Hydraulic pump-to-engine coupler has slipped. | Check for wear and replace both coupler halves and rubber spider as needed. |

B. TYNES FAIL TO ROTATE

- | | |
|---------------------|--|
| 1. Tyne motor worn. | Rebuild or replace motor. New motors are available from Red Roo. |
|---------------------|--|

C. ENGINE LUGS DOWN OR DIES AND TINES DO NOT TURN.

- | | |
|---|--|
| 1. Rocks or other obstruction blocking tines. | Shut OFF engine and remove obstruction or reverse tynes. |
| 2. Tyne shaft bound with wire, vines, or grass. | Shut OFF engine and remove debris, especially at the ends. |
| 3. Outboard tine shaft bearings binding. | Lubricate or replace bearings as needed. |
| 4. Engine improperly tuned or maintained. | See engine manual and correct as needed. |
| 5. Low oil alert causes engine to shut down. | This may occur if tilling on hills, (not advised). Level the tiller and check engine oil level. Fill if required. Oil alert should reset. See engine manual. |
| 6. Engine losing power due to wear. | See engine manual. |

D. OIL LEAKS IN HYDRAULIC SYSTEM.

- | | |
|--------------------------|-----------------------|
| 1. Fittings are loose. | Tighten as required. |
| 2. Worn or broken hoses. | Replace as necessary. |

E. EXCESSIVE FOAMING OF HYDRAULIC OIL FROM VENT HOSE.

- | | |
|-----------------------|--|
| 1. Improper oil used. | Verify that hydraulic oil used has anti-foaming additives. |
| 2. Pump sucking air. | Inspect and tighten fittings on intake side of pump. |



WORK SITE ASSESSMENT

Examine the work area for any conditions or obstructions that may inhibit tilling or create a safety hazard for the operator or others. Use the information in this manual combined with good judgment to identify any hazards to avoid.

In addition to calling to DETERMINE LOCATION OF UNDERGROUND UTILITIES (see previous section for details), the operator and/or job foreman should visually inspect the work site. Look for electrical drop boxes, notices of underground placements, manhole covers, recent trenching or tilling activity, any evidence of possible underground placements, banks, drop-offs, rocks, wire, uneven terrain, any existing holes and toxic ground conditions.



Only operate tiller outdoors and avoid breathing engine exhaust and fumes.
WARNING: Engine exhaust contains carbon monoxide gas that is toxic. Breathing it can cause unconsciousness and death.



Do not operate tiller near any source of flammable dust or vapors.
WARNING: Sparks from the engine exhaust can cause an explosion or fire in a flammable or explosive atmosphere. Fuel fumes can catch fire or explode.

Allow adequate side and overhead clearances between tiller and any objects such as buildings, fences, and trees.

Adequate lighting is required, daylight or artificial, for safe operation of the tiller.

Keep others away. If the job site is near a road or pedestrian path, warn and divert both motorized traffic and pedestrians. As appropriate, erect barriers, use traffic flag personnel, signs, cones, and lighting devices to insure safety.



WARNING: Someone could step into the tilled area by accident. Walking near the edge of the tilled area could cause loss of balance and possibly cause someone to fall into the rotating tynes. Contact with the rotating tynes while in operation will cause serious injury or even death.

MACHINE FUNCTION CHECK: If the operator releases the TYNE ENGAGEMENT CONTROL LEVER, the rotating tynes should stop. This is intended for your safety and must be maintained in good functional condition. Contact your dealer or the factory if anything on the tiller does not function properly.



ITEM NO.	QTY.	PART NO.	DESCRIPTION	ITEM NO.	QTY.	PART NO.	DESCRIPTION
1	1	12191	TINE DRIVER	15	1	12206-22	TINE SHAFT, 22"
2	16	05061	HH CAP SCREW, 7/16-20 NF X 1 G8 ZINC	16	2	10800	HYDRAULIC FITTING, 6400-0-6-10
3	8	05063	HH CAP SCREW, 7/16-20 NF X 1-1/4 G8 ZINC	17	1	05083	WASHER, 7/16 USS ZINC
4	1	12209	SAUER 125cc	18	1	05103	WASHER, 3/8 A325 HARDENED ZINC
5	1	12192	DIRT SHIELD	19	1	05059	HH CAP SCREW, 3/8-16 NC X 1 G5 ZINC
6	1	12194	SHAFT SPACER	20	2	12189	SPACER RING
7	1	10144	OUTBOARD BEARING ASSEMBLY	21	1	12234	MOTOR GUARD
8	12	03196	TINE, REVERSIBLE	22	3	05169	WHIZ LOCK, 5/16-18 NC X 1/2 ZINC
9	1	12195-22	TINE FRAME, 22"	23	1	03040-04	DECAL, "GREASE DAILY"
10	4	05057	HH CAP SCREW, 3/8-16 NC X 3/4 G5 ZINC				
11	24	05074	NUT, 7/16-20 NF G8 ZINC				
12	6	05131	HH FLANGE SCREW, 5/16-18 NC X 3/4 G8 ZINC				
13	6	05273	NUT, NYLOCK, 5/16-18 NC ZINC				
14	1	05044	GREASE ZERK, 1/4-28 UNF				

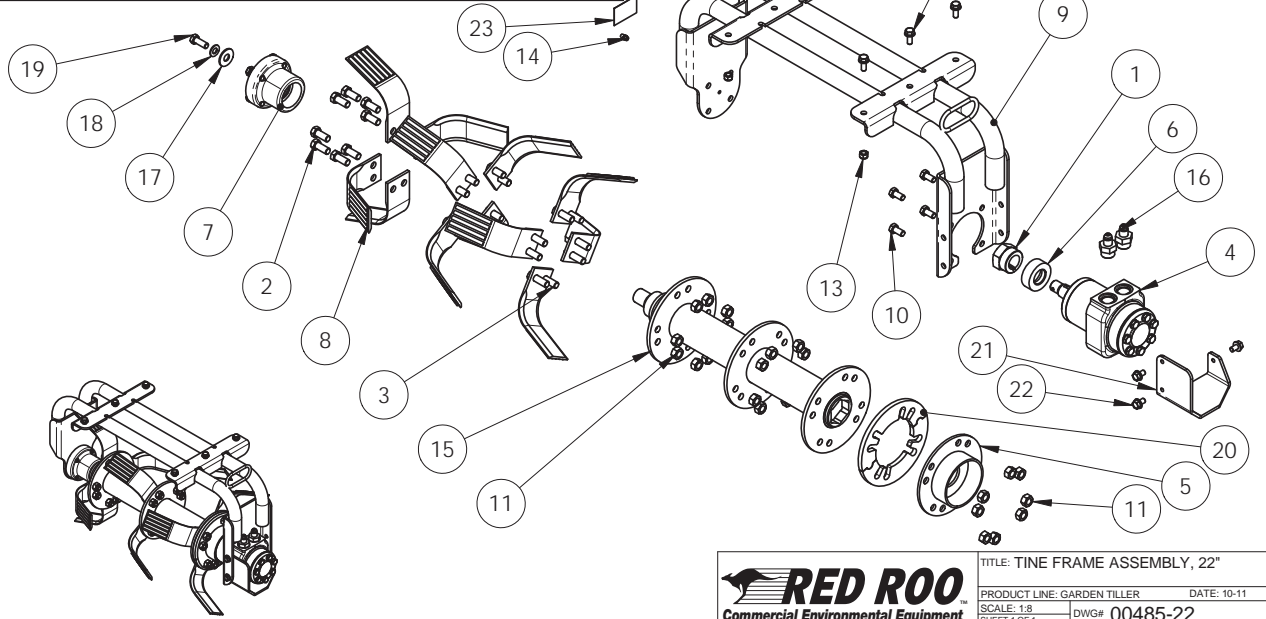

ITEM NO.	QTY.	PART NO.	DESCRIPTION
1	1	07011	ENGINE, 5.5 HP HONDA GX160
2	1	11002	JAW COUPLER, 3/4" BORE, L075
3	1	11996	SPIDER, URATHANE, L075
4	1	11003	JAW COUPLER, 1/2" BORE, L075
5	1	11147	PUMP, SNP1 4cc
6	1	12198	PUMP ADAPTER
7	12	05068	WASHER, 5/16 SAE ZINC
8	4	05052	HH CAP SCREW, 5/16-24 NF X 3/4 G5 ZINC
9	2	05297	HH CAP SCREW, 5/16-18 NC X 1-1-4 G5 ZINC
10	6	05273	NUT, NYLOCK, 5/16-18 NC ZINC
11	1	10404	FITTING, 6801-6-8
12	1	04523	FITTING, 4601-12-10
13	4	05294	HH CAP SCREW, 5/16-18 NC X 1-1/2 G5 ZINC

ENGINE OPTIONS:
HONDA GX160, PN 07011
SUBARU / ROBIN, PN 07013

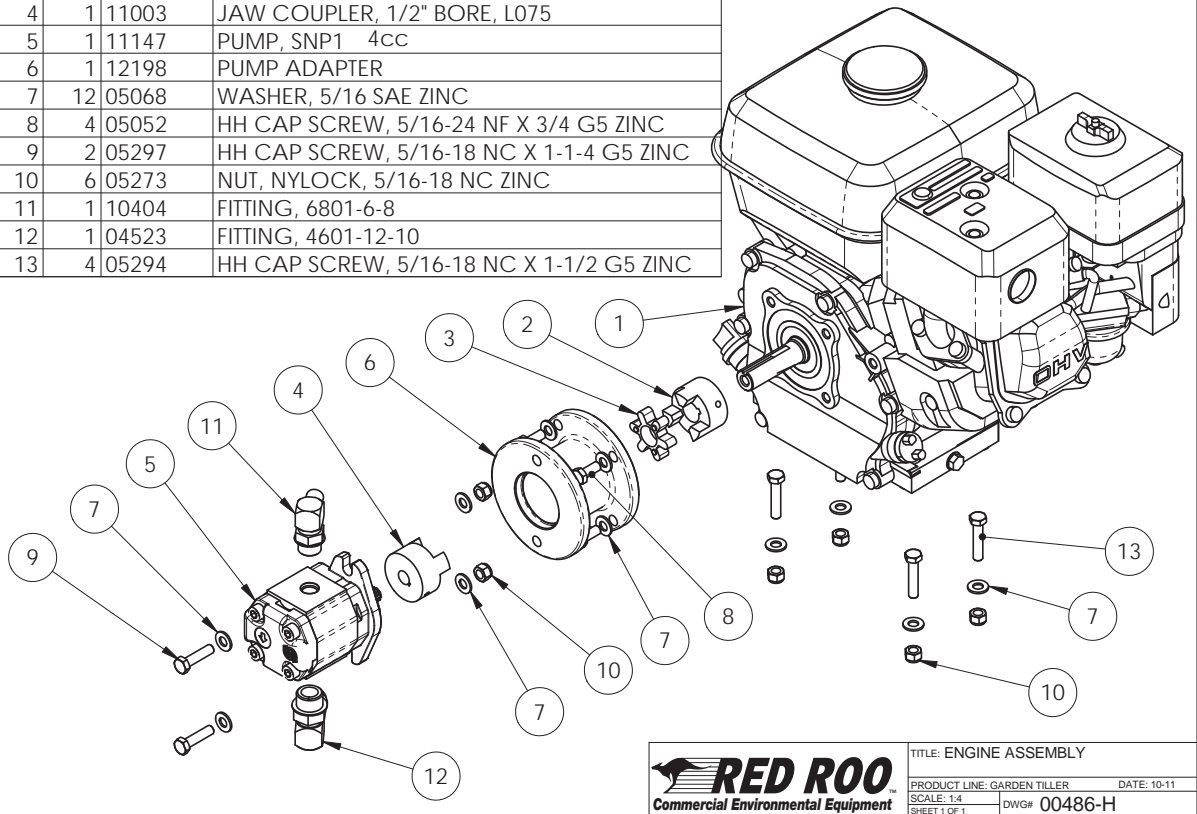

ITEM NO.	QTY.	PART NO.	DESCRIPTION
1	1	00486	ENGINE ASSEMBLY
2	1	00485-22	TINE ASSEMBLY, 22"
3	1	00493	FRAME ASSEMBLY
4	1	00488	CONTROL ASSEMBLY
5	1	00489	WHEEL ASSEMBLY
6	1	11987	BREATHER HOSE ASSY
7	1	04555	FITTING, 6801-4-4
8	1	12214	HOSE, SUCTION 3/4"
9	2	05008	CLAMP, 1" HOSE, CTB-29
10	1	12360	TUBE CLAMP, 3/4", 265-024
11	1	12213	HOSE, PUMP / VALVE, 3/8"
12	1	12216	HOSE, VALVE FR / MOTOR FR, 3/8"
13	1	12215	HOSE, VALVE REAR / CHECK
14	1	12242	CHECK VALVE BODY
15	1	12243	ORIFICE PLUG
16	1	10401	FITTING, 6400-6-6
17	1	04226	FITTING, 6400-6-8
18	1	12245	HOSE, MOTOR RETURN / CHECK
19	1	12205	HOSE 3/8". VALVE / FILTER

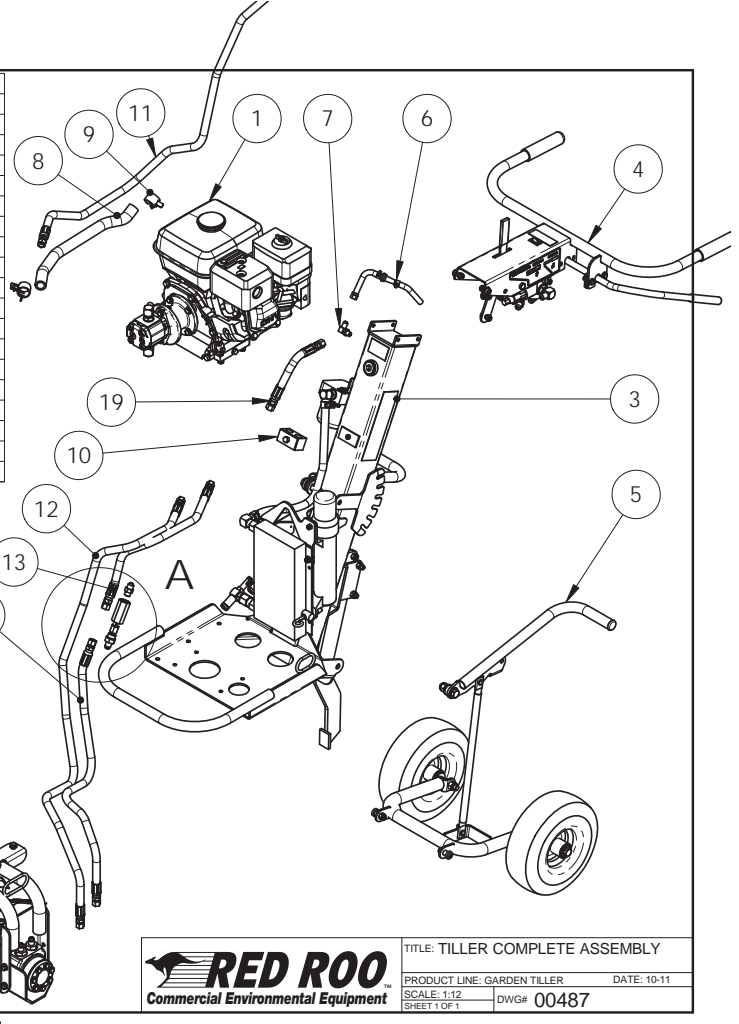

TITLE: TILLER COMPLETE ASSEMBLY
 PRODUCT LINE: GARDEN TILLER DATE: 10-11
 SCALE: 1:12 SHEET 1 OF 1 DWG# 00487

ITEM NO.	QTY.	PART NO.	DESCRIPTION
1	1	12202	HANDLEBAR
2	1	11287	ROQUET VALVE, 6102-TIPOS
3	1	12203	VALVE ROCKER
4	1	12210	FULCRUM
5	1	12204	VALVE LEVER
6	5	05273	NUT, NYLOCK, 5/16-18 NC ZINC
7	1	03017	MASTER LINK, #50 CHAIN
8	4	12235	BEARING
9	9	05081	WASHER, 1/4 SAE ZINC
10	4	05237	HH CAP SCREW, 1/4-20 NC X 1 G5 ZINC
11	4	05096	NUT, NYLOCK, 1/4-20 NC ZINC
12	1	05038	RUE RING COTTER #8
13	2	03032-01	GRIP, 1 X 5 (P/N 03032 IS A PAIR)
14	1	06420	ROCKER SWITCH, IGNITION OFF/ON
15	1	06421	GROUND WIRE, IGNITION SWITCH
16	1	03806	QUICK-SPLICE
17	2	05068	WASHER, 5/16 SAE ZINC
18	2	05568	HH CAP SCREW, 5/16-18 NC X 2-1/2 G5 ZINC
19	2	10404	FITTING, 6801-6-8
20	2	04538	FITTING, 6801-6-6
21	1	12342	ADJUST LEVER
22	1	10599	HH CAP SCREW, 3/8-16 NC X 4-1/2 G5 ZINC
23	1	05073	NUT, NYLOCK, 3/8-16 NC ZINC
24	1	05269	NUT, 3/8-16 NC GRB ZINC
25	3	05351	SH SHOULDER SCREW, 3/8 X 1/4
26	1	03066	SPRING, CENTURY S774
27	2	05101	WASHER, 3/8 SAE ZINC
28	1	03018	GRIP, 1/8 X 3/4 X 2-3/4
29	1	04406-01	TINE DECAL
30	1	03341-07	DECAL, "IGNITION OFF/ON"
31	2	07007-11	HH FLANGE SCREW, 6mm-1.0 X 12mm ZINC
32	1	03093	GRIP, .625 X 4.5

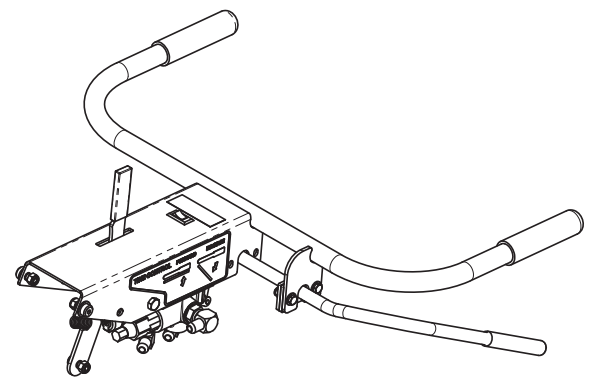

TITLE: CONTROL ASSEMBLY
 PRODUCT LINE: GARDEN TILLER DATE: 3-12
 SCALE: 1:8 SHEET 1 OF 2 DWG# 00488

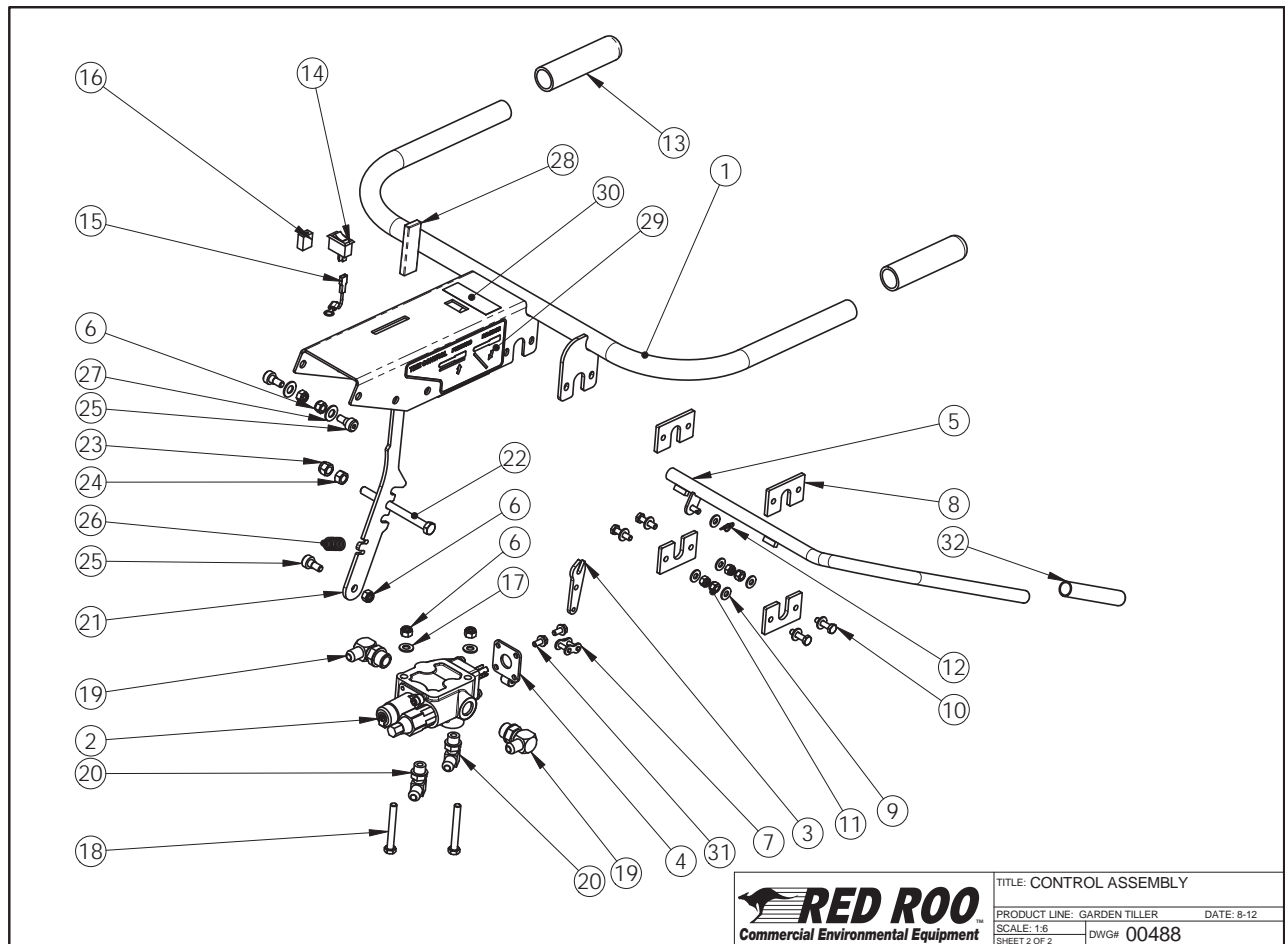

ITEM NO.	QTY.	PART NO	DESCRIPTION
1	1	11745	SWING ARM
2	1	11747	RAISE LINK
3	1	11746L	LIFT LEVER
4	1	10257	HH CAP SCREW, 1/2-20 NF X 1-3/4 G5 ZINC
5	1	11113	CUSHION
6	2	05102	WASHER, 1/2 SAE ZINC HARDENED
7	1	03200	THRUST WASHER, .75 X 1 X .060, HARD
8	1	05075	NUT, NYLOCK, 1/2-20 NF ZINC
9	2	10276	HH CAP SCREW, 1/2-13 NC X 6 G5 ZINC
10	2	05073	NUT, NYLOCK, 3/8-16 NC ZINC
11	2	05098	NUT, NYLOCK, 1/2-13 NC ZINC
12	2	11056	NUT, JAM, 1/2-13 NC G5 ZINC
13	2	05101	WASHER, 3/8 SAE ZINC
14	2	05222	COTTER PIN 1/8 X 3/4
15	2	05183	BH SHOULDER SCREW, 1/2D X 3/4L
16	1	12151	TUBE CAP, 1.0 X 7/8
17	2	10347	TIRE & RIM 4.10/3.50-4
18	2	10458	SPACER, FRONT AXLE
19	4	10347.50	BEARING, 1/2 BORE

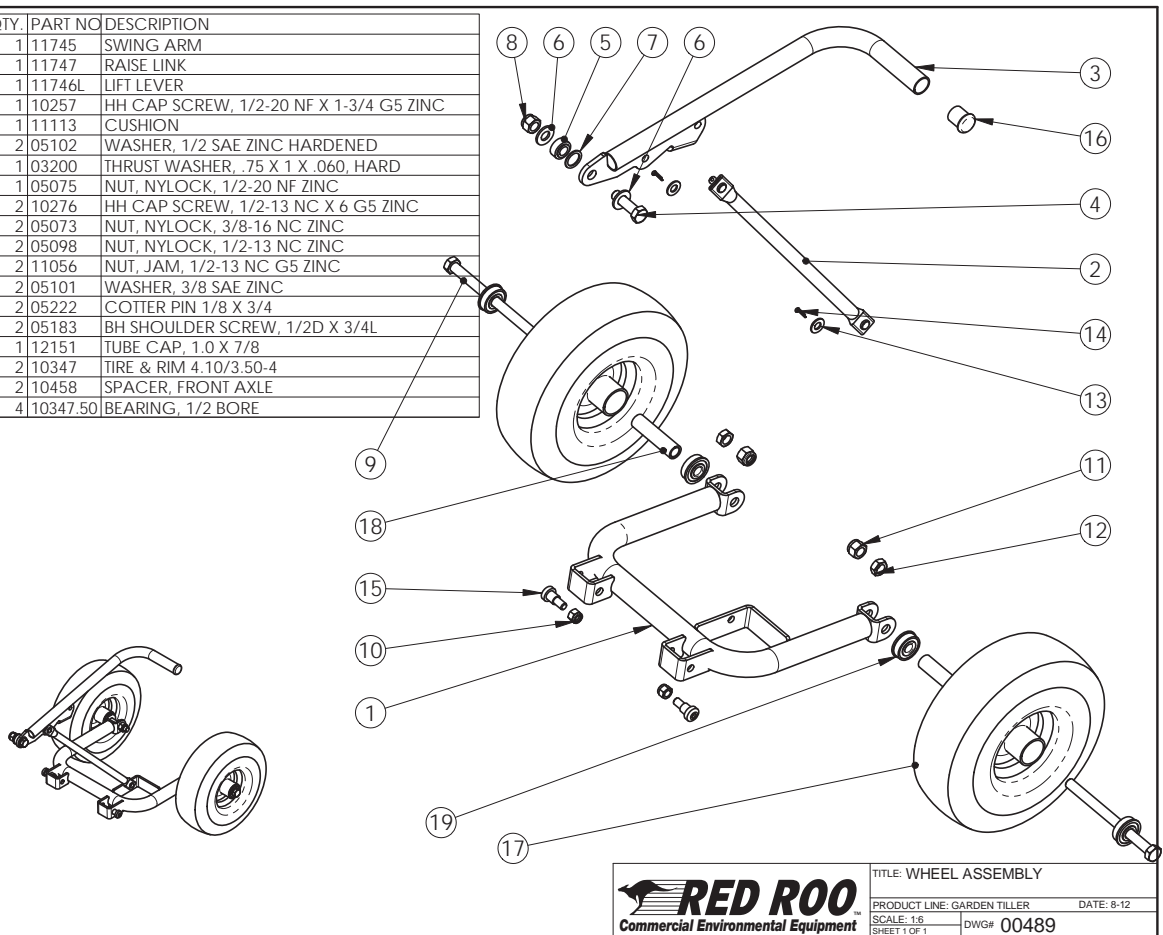

ITEM NO	QTY	PART NO.	DESCRIPTION	ITEM NO	QTY	PART NO.	DESCRIPTION
1	1	11997	FITTING, 4501-8-8	36	2	05352	HH CAP SCREW, 3/8-16 NC X 2-1/4 G5 ZINC
2	1	10527	OIL COOLER, B & M 70273, 11 X 5.75	37	2	05101	WASHER, 3/8 SAE ZINC
3	1	06423	STARTER GROMMET	38	1	11667	FITTING, 4604-8-6
4	1	12197	FRAME	39	1	04216	FITTING, 4603-8-8
5	2	05092	HH CAP SCREW, 3/8-16 NC X 1-1/2 G5 ZINC	40	1	12208	DRAG BAR
6	4	05073	NUT, NYLOCK, 3/8-16 NC ZINC	41	1	12090	INSTRUCTION CANISTER
7	2	12230	SPACER	42	1	03040-11	DECAL, "BARRETO", 2-3/16 X 7-3/8
8	11	05081	WASHER, 1/4 SAE ZINC	43	1	04406-02	DECAL, 622-GT
9	2	05069	WHIZ LOCK, 1/4-20 NC X 5/8 ZINC	44	1	03040-06	DECAL, "HYDRAULIC OIL ONLY"
10	7	05096	NUT, NYLOCK, 1/4-20 NC ZINC	45	1	12151	TUBE CAP, 1.0 X 7/8
11	2	05049	WHIZ LOCK, 1/4-20 NC X 3/4 ZINC	46	1	04569	FITTING, 6404-8-8
12	1	12207	ROPE GUIDE MOUNT	47	1	10529-P	FITTING, 4601-12-8 T6
13	1	10361	FITTING, 6409-8 PLUG	48	1	03009	HOUR METER - COMPLETE KIT
14	1	10526	FITTING, 6409-12 PLUG				
15	1	03503	SIGHT GAUGE				
16	1	03087	OIL FILTER, FRAM PH 3614				
17	1	12196	FILTER HEAD				
18	1	10404	FITTING, 6801-6-8				
19	1	04574-M	FITTING, 4604-8-8, CUT				
20	1	04572	FITTING, 4601-8-8				
21	1	03232	O-RING, 2-014, 5/8 OD X 1/16 SECTION				
22	1	12199	FILTER BRACKET				
23	2	05557	HH CAP SCREW, 1/4-20 NC X 1/2 G5 ZINC				
24	2	05556	HH CAP SCREW, 1/4-20 NC X 1-3/4 G5 ZINC				
25	4	12131	CLAMP, 1/2" HOSE, CTB-22				
26	1	12217	HOSE, 1/2"				
27	1	12218	HOSE, 1/2" COOLER / TANK				
28	1	12155	LINK				
29	2	12156	LINK SPACER				
30	1	11113	CUSHION				
31	1	03200	THRUST WASHER, .75 X 1 X .060, HARD				
32	1	11746R	DRAG LEVER				
33	1	05102	WASHER, 1/2 SAE ZINC, HARDENED				
34	1	05251	HH CAP SCREW, 1/2-20 NF X 2 G5 ZINC				
35	1	05075	NUT, NYLOCK, 1/2-20 NF ZINC				

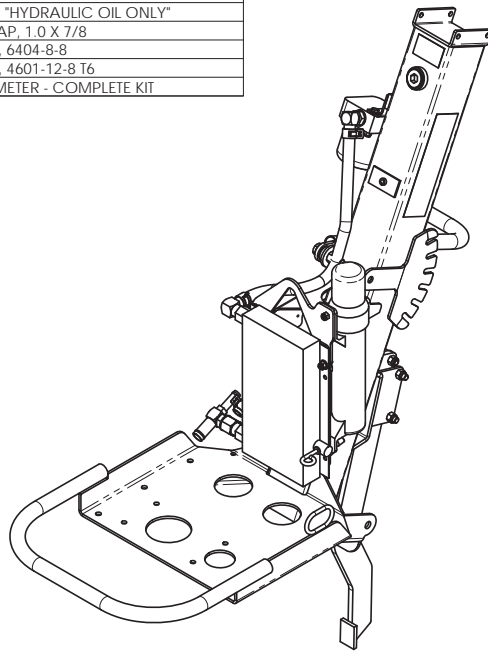

RED ROO
Commercial Environmental Equipment

TITLE: FRAME ASSEMBLY
PRODUCT LINE: GARDEN TILLER DATE: 1-12
SCALE: 1:8 DWG# 00493
SHEET 1 OF 2

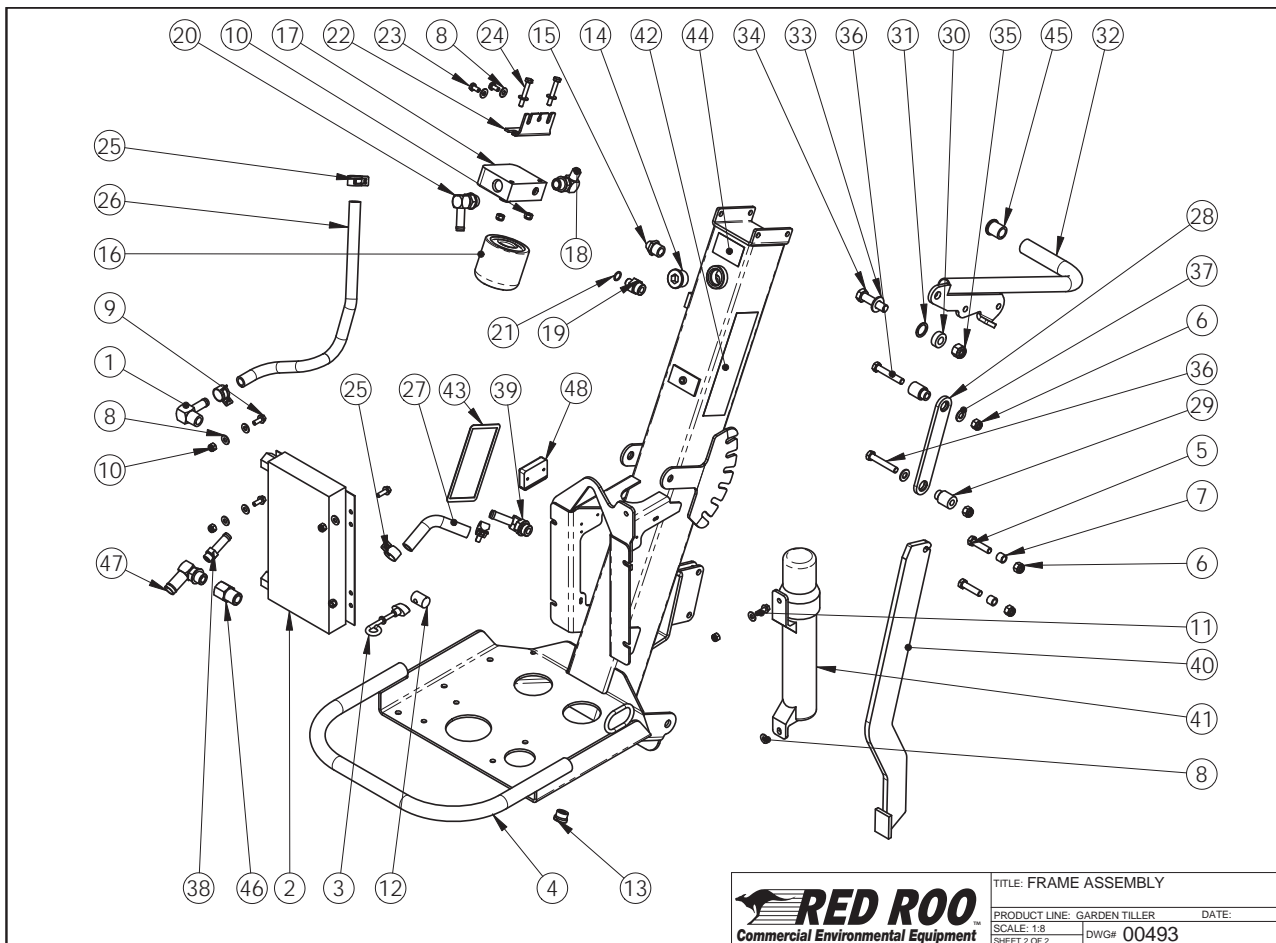

RED ROO
Commercial Environmental Equipment

TITLE: FRAME ASSEMBLY
PRODUCT LINE: GARDEN TILLER DATE: 1-12
SCALE: 1:8 DWG# 00493
SHEET 2 OF 2

Hop to **redroo.com**



1300 133 767

[Home](#) [Products](#) [Parts & Accessories](#) [Videos](#) [Red Roo Rents](#) [Red Roo Media](#) [Support](#) [Our Company](#) [Contact Us](#)

PRODUCTS

Red Roo provide extensive range of Commercial Environmental Equipment to Hire and Rental Industry, Arborist, Local Government Council



[Chippers, Shredders & Mulchers](#)



[Commercial Wood Chippers](#)



[Stump Grinders - Up to 27hp](#)



[Stump Grinders - Up to 250hp](#)



[Log Splitters](#)



[Post Hole Diggers](#)



[Rotary Hoes](#)



[Trenchers](#)



[Trailers](#)



[Turf Cutters](#)



[Aerator](#)



[Rigging Gear](#)

and explore our **PRODUCTS**



Commercial Environmental Equipment

Superseding Warranty
Red Roo Group of Companies

Warranty Policy
effective September 12, 2012

Replaces all undated previous Warranties and all Warranties dated prior to January 1, 2010.

"For a time period shown below from date of purchase, pending owner registration, Red Roo Sales & Service Company, P/L, herein referred to as "MANUFACTURER", will, at its option, repair or replace for the original purchasers of new Red Roo equipment, free of charge, any part, or parts of the unit (excluding Power Unit, warranty coverage provided by respective engine manufacturer), found upon inspection and testing by a Factory Authorised Agent, or by the Factory at Keysborough, Victoria, to be defective in material or workmanship or both under normal operating conditions; this is the exclusive remedy. All transportation charges on parts submitted to the MANUFACTURER for replacement under this Warranty are the responsibility of the purchaser.

This Warranty shall not apply to any product that has been altered, modified, or operated in a manner not approved or recommended by the MANUFACTURER. Warranty will be null and void in the following circumstances: (1) repairs or attempted repairs have been performed by persons other than agents authorised by the MANUFACTURER; (2) repairs are required because of normal wear; (3) the unit has been subject to abuse or involved in an accident; (4) misuse is evident, such as that caused by an application that unit is not intended to perform.

The MANUFACTURER reserves the right to modify, alter, or otherwise improve any product or part.

The purchaser is responsible for the performance of regular maintenance services as specified in the operator manual applicable to the unit. Untimely and/or improper care and replacement of normal maintenance items (eg.: filters, belts, drive chains, blades, knives, lubricants) may void Warranty. Use of non genuine Red Roo parts may void Warranty.

THERE IS NO OTHER EXPRESS WARRANTY. IMPLIED WARRANTIES, INCLUDING THOSE OF MERCHANTABILITY AND FITNESS FOR A PARTICULAR PURPOSE ARE LIMITED TO 14 DAYS FROM PURCHASE, AND TO THE EXTENT PERMITTED BY LAW ANY AND ALL IMPLIED WARRANTIES ARE EXCLUDED. LIABILITY FOR CONSEQUENTIAL DAMAGES UNDER ANY AND ALL WARRANTIES ARE EXCLUDED TO THE EXTENT EXCLUSION IS PERMITTED BY LAW. RED ROO GROUP OF COMPANIES DOES NOT AUTHORISE ANY PERSON OR ENTITY TO CREATE FOR IT ANY OTHER OBLIGATION OR LIABILITY IN CONNECTION WITH ITS PRODUCTS OR SERVICES. Some states do not allow limitations on how long an implied warranty lasts, and some states do not allow the exclusion of limitation of incidental or consequential damages, so the above limitation exclusion may not apply to you. This warranty gives you specific legal rights and you may also have other rights which vary from state to state."

Red Roo Sales & Service Company, P/L
James A. Kerr III
Managing Director

Warranty Period

All Equipment	Consumer Use* 365 Days	Commercial Use* 90 Days
---------------	---------------------------	----------------------------

* For the purposes of this warranty policy, "consumer use" shall mean personal residential household use by the original retail consumer. "Commercial use" shall mean all other uses, including use for commercial, income producing or hire purposes. Once a unit has experienced commercial use, it shall thereafter be considered as a commercial use unit for purposes of this warranty policy.

Proper registration of your Red Roo equipment is required to obtain warranty service. It is the responsibility of the original purchaser to register equipment within 10 days of purchase.

