

# CORDLESS SCARIFIER UV001G

## REPAIR MANUAL



# 1 CONTENTS

1	CONTENTS .....	2
2	CAUTION .....	3
3	NECESSARY REPAIRING TOOLS .....	3
4	LUBRICANT AND ADHESIVE APPLICATION .....	4
5	TIGHTENING TORQUE SPECIFICATIONS .....	4
6	REPAIR .....	5
6-1	Grass catcher section .....	5
6-1-1	Disassembling .....	5
6-1-2	Assembling .....	5
6-2	Blade section .....	6
6-2-1	Disassembling .....	6
6-2-2	Assembling .....	7
6-3	Switch box section and handle section .....	8
6-3-1	Disassembling .....	8
6-3-2	Assembling .....	11
6-4	Cowling section .....	14
6-4-1	Disassembling .....	14
6-4-2	Assembling .....	19
6-5	Motor section .....	25
6-5-1	Disassembling .....	25
6-5-2	Assembling .....	31
6-6	Deck section and Wheel section .....	37
6-6-1	Disassembling .....	37
6-6-2	Assembling .....	39
7	CUIT DIAGRAM .....	42
8	WIRING DIAGRAM .....	43
8-1	Power supply cord unit section .....	43
8-2	Lever box section .....	43
8-3	Motor housing section .....	44
8-4	Terminal unit section .....	44
8-5	Deck section .....	45
9	TROUBLESHOOTING .....	46
9-1	Note for Repairing .....	46
9-2	Flowchart for Troubleshooting .....	47

## 2 CAUTION

Repair the machine in accordance with "Instruction manual" or "Safety instructions".

Follow the instructions described below in advance before repairing:

- Wear gloves.
- In order to avoid wrong reassembly, draw or write down where and how the parts are assembled, and what the parts are. It is also recommended to have boxes ready to keep disassembled parts by group.
- Handle the disassembled parts carefully. Clean and wash them properly.
- Remove Batteries, except when they are necessary to check the operation of the machine.

## 3 NECESSARY REPAIRING TOOLS

Code No.	Description	Use for
1R045	Gear puller large	removing Motor housing and Rotor
1R131	Bearing puller for 1R089 12-15	pulling out Ball bearing 6001DDW
1R263	Bearing pry bar	removing Bearing cover
1R267	Spring pin extractor 2.5	removing/assembling Spring pin 2.5-16
1R269	Bearing puller small	removing Ball bearing 608DDW
1R350	Ring 60-78-30	pushing out Shaft 17 and Ball bearing 6003LLU
1R461	Grip for spring pin extractor	removing/assembling Spring pin 2.5-16
1R463-07	Ring 8-608-628	press-fitting Ball bearing 608DDW
1R479	Shockless hammer (Small)	removing Pulley holder and Stator
1R495	Slotted screwdriver (Small)	<ul style="list-style-type: none"> <li>• removing Switch unit, Strain relief, Sleeve, Plate nut M8, Lead unit</li> <li>• removing/assembling Stop ring E-5 and Rod 6</li> </ul>

#### 4 LUBRICANT AND ADHESIVE APPLICATION

Description	Amount
Makita grease FA No.2	a little
Fig. 1	

#### 5 TIGHTENING TORQUE SPECIFICATIONS

Parts to fasten	Fastener	Q'ty	Tightening torque [N·m]
↔ Cowling	Tapping screw 4x20	9	1.0 - 1.3
↔ Plate		2	
↔ Terminal housing F		2	
↔ Terminal housing R		2	
Motor housing ↔ Baffle plate		2	
Switch box R ↔ Switch box L		6	
Lever box R ↔ Lever box L		4	
Motor housing ↔ Pulley holder	Tapping screw 5x20	4	1.5 - 2.0
Deck ↔ Shaft holder		3	
		2	
Clamp ↔ Handle lower	Pan head screw M4x35	1	0.6 - 1.0
Rotor ↔ Pulley 20	Hex nut M8-13	1	11 - 15

## 6 REPAIR

### 6-1 Grass catcher section

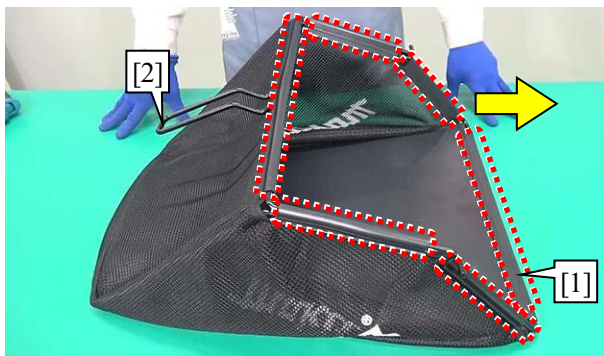
#### 6-1-1 Disassembling

Fig. 2



- 1 Open Rear flap [2] with Handle section [1] raised upward, then lift up and remove Grass catcher section [3].

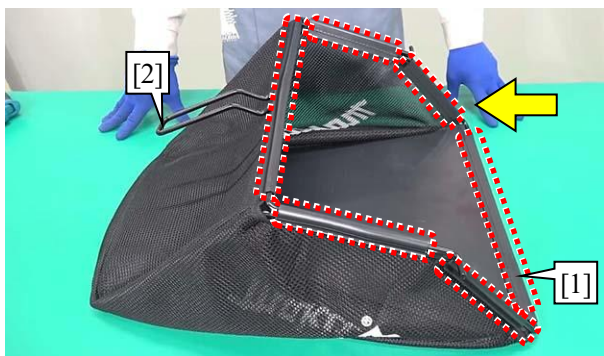
Fig. 3



- 2 Release the resin hook portions (6 positions) of Grass catcher [1], then remove Grass catcher bracket [2] from Grass catcher [1].

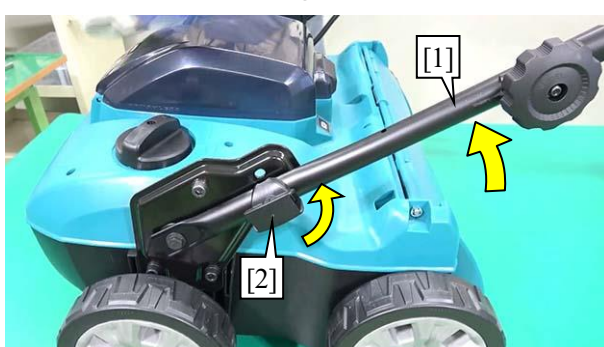
#### 6-1-2 Assembling

Fig. 4



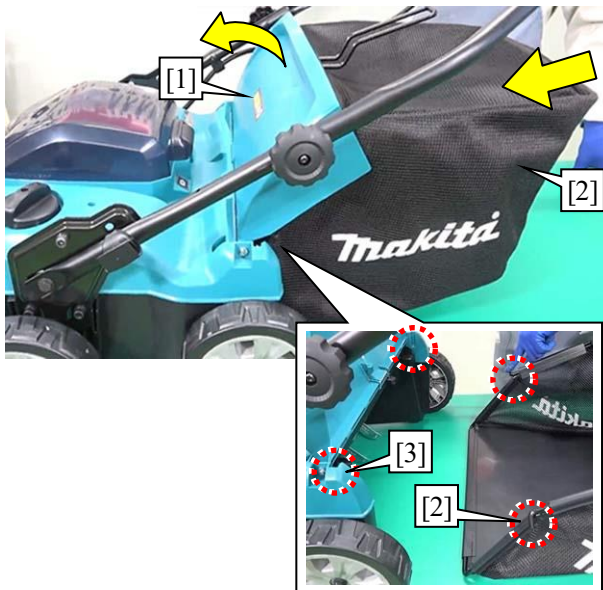
- 1 Assemble Grass catcher bracket [2] to Grass catcher [1], then assemble the resin hook portions (6 positions) of Grass catcher [1].

Fig. 5



- When Handle section is lowered.
- 2 Flip up Handle section [1], then fix Handle section [1] by turning Knob [2] 90°.

Fig. 6



- 3 Flip up Rear flap [1], then assemble Grass catcher [2].

**Tips**

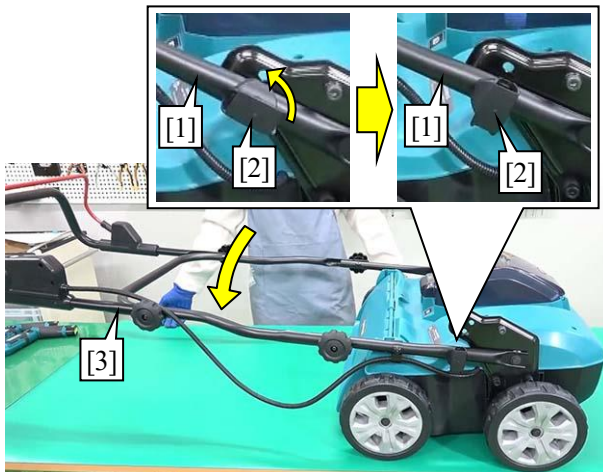
Assemble Grass catcher [2] by inserting its hooks into the slits of Cowling [3].

- 4 Lower Rear flap [1].

## 6-2 Blade section

### 6-2-1 Disassembling

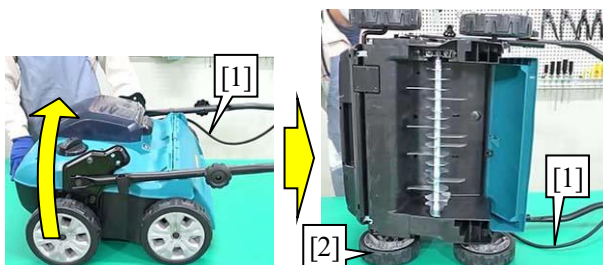
Fig. 7



- Preparation before disassembling Blade.

- 1 Pull Knobs [2] on the left and right side of Handle lower [1] to release the lock by turning them 90°, then lower Handle section [3].

Fig. 8



- Preparation before disassembling Blade.

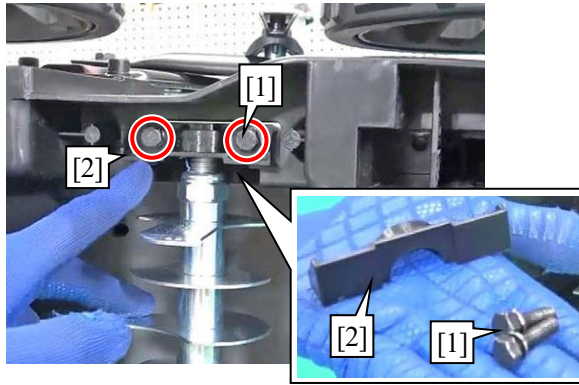
- 2 Stand the machine on its side.

**Tips**

- Stand the machine so that Power supply cord unit [1] faces downward.
- Stand the machine while supporting it with Tire section [2].

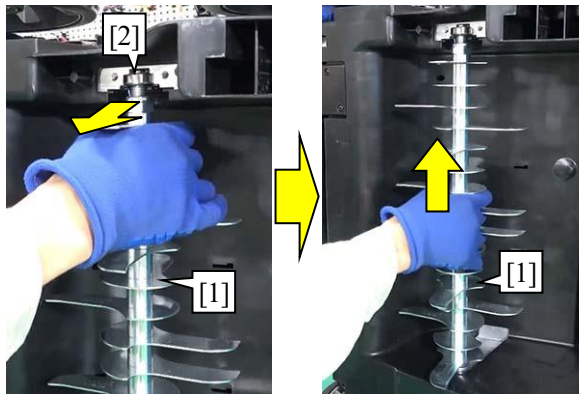


Fig. 9



- 3 Remove Hex bolts M6x20 [1] (2 pcs), then remove Blade under bracket [2].

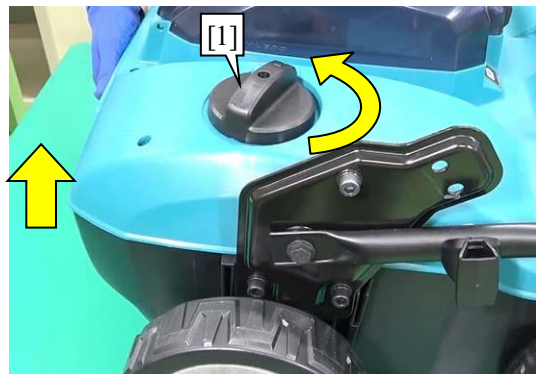
Fig. 10



- 4 Pull Bearing section [2] of Vertical cutter [1] toward you, then lift it up to remove Vertical cutter [1].

## 6-2-2 Assembling

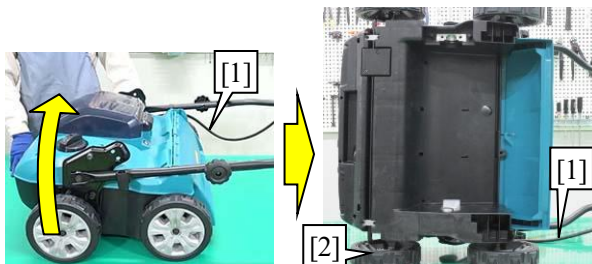
Fig. 11



■ Preparation before assembling Blade.

- 1 Turn Dial 75 [1] counterclockwise to set the height of Blade to the highest position.

Fig. 12



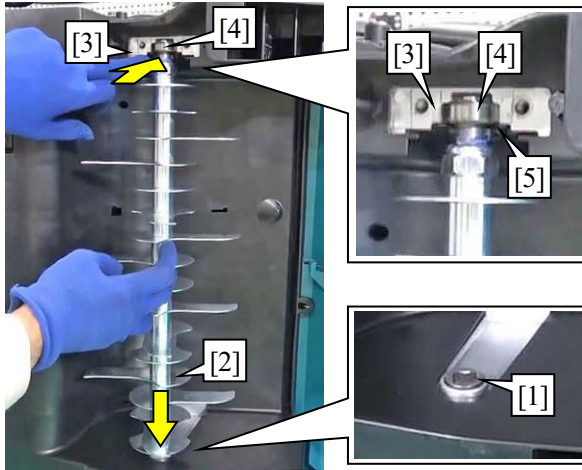
■ Preparation before assembling Blade.

- 2 Stand the machine on its side.

### Tips

- Stand the machine so that Power supply cord unit [1] side faces downward.
- Stand the machine while supporting it with Tires section [2].

Fig. 13

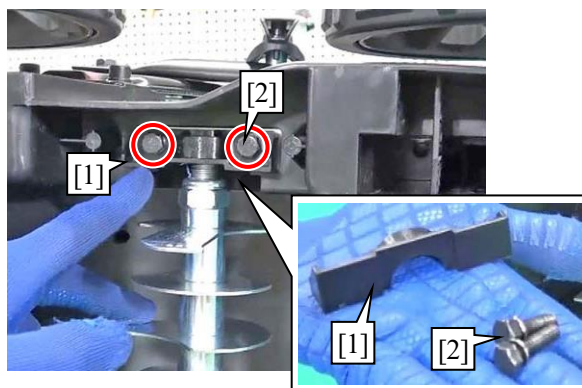


- 3 Insert Vertical cutter [2] into the square hole of Deck [1], then assemble Bearing section [4] of Vertical cutter [2] into Shaft holder [3].

**Note**

Check that Bearing section [4] of Vertical cutter [2] is assembled on Bearing retainer [5].

Fig. 14

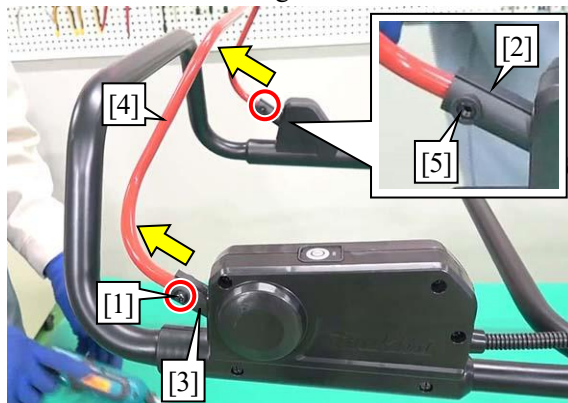


- 4 Assemble Blade under bracket [1], then tighten Hex bolts M6x20 [2] (2 pcs) with a 10mm Socket bit and an impact driver.

### 6-3 Switch box section and handle section

#### 6-3-1 Disassembling

Fig. 15



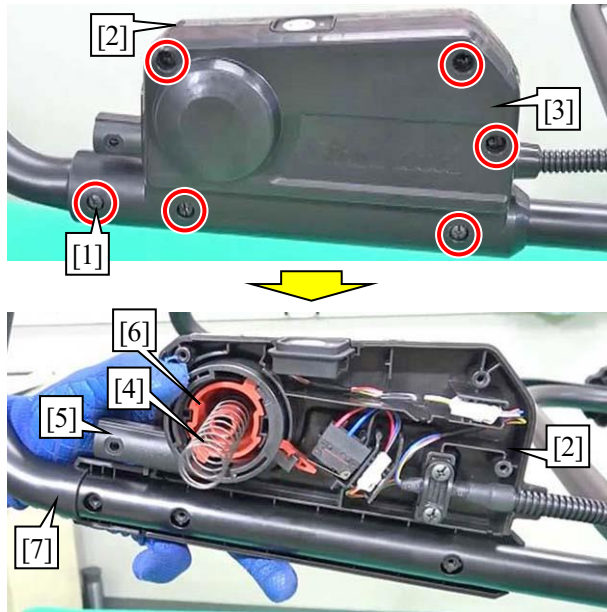
- 1 Remove P.H.screws M4x20 with WR [1] (2 pcs), then remove Switch lever [4] from Switch lever support L [2] and Switch lever support R [3].

**Note**

Be careful that Hex nuts M4 [5] (2 pcs) do not fall off from Switch lever support L [2] and Switch lever support R [3].



Fig. 16



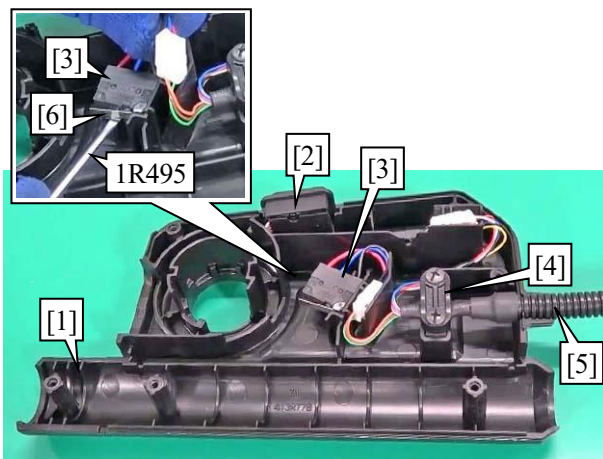
- 2 Remove Tapping screws 4x20 [1] (6 pcs), then remove Switch box R [3] from Switch box L [2].

Note

Remove the last one of Tapping screw 4x20 [1] while holding Switch box L [2] and Switch box R [3] to prevent parts from popping out due to the tension of Compression spring 15 [4].

- 3 Remove the following parts from Switch box L [2]:
  - Compression spring 15 [4]
  - Switch lever support R [5]
  - Lock off button [6]
- 4 Remove Switch box L [2] from Handle upper [7].

Fig. 17

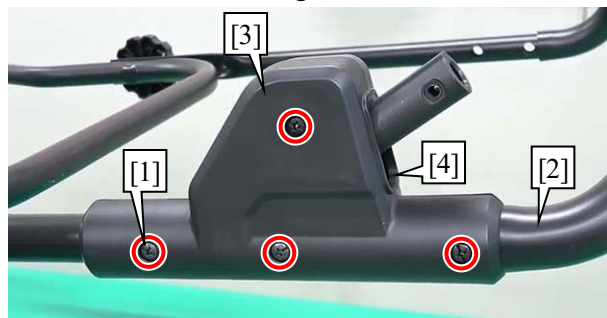


- 5 Remove the following parts from Switch box L [1]:
  - Switch circuit [2]
  - Switch unit [3]
  - Strain relief [4]
  - Power supply cord unit [5]

Note

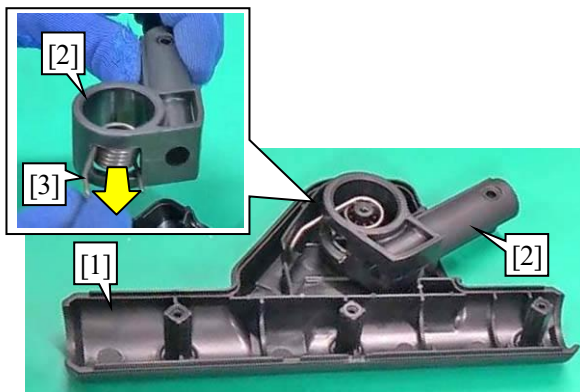
• When removing Switch unit [3], lift up and remove the resin portion of Switch unit [3] with 1R495.  
• Be careful not to lift up Actuator [6] because it will be damaged if a lateral force is applied.

Fig. 18



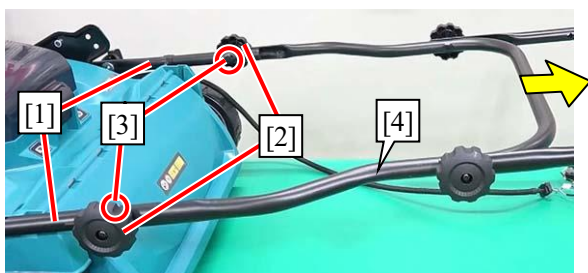
- 6 Remove Tapping screws 4x20 [1] (4 pcs), then remove Lever box L [3] and Lever box R [4] from Handle upper [2].

Fig. 19



- 7 Remove Switch lever support L [2] from Lever box R [1].
- 8 Remove Torsion spring 12 [3] from Switch lever support L [2].

Fig. 20

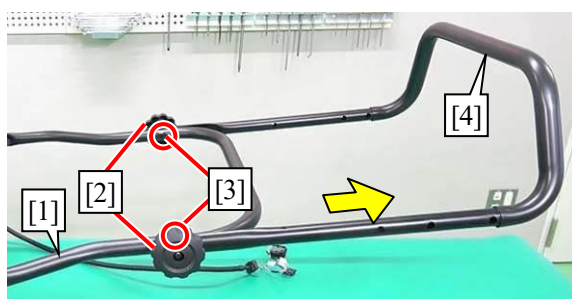


- 9 Remove Thumb nuts M8 [2] (2 pcs) from Handle lowers [1] (2 pcs), then remove Flat head bolts M8x50 [3] (2 pcs) and Handle middle [4].

Note

- Remove Flat head bolt M8x50 [3] by screwing it out while pulling it, because a part of the shank has a non-thread portion as fall prevention bolt.
- Be careful not to fall off Handle middle [4].

Fig. 21

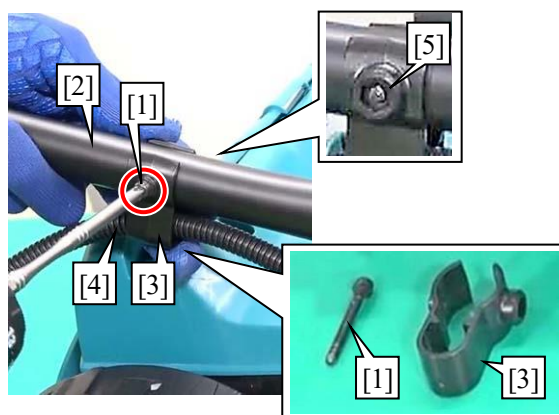


- When disassembling Handle middle and Handle upper
- 10 Remove Thumb nuts M8 [2] (2 pcs) from Handle middle [1], then remove Flat head bolts M8x50 [3] (2 pcs) and Handle upper [4].

Note

- Remove Flat head bolt M8x50 [3] by screwing it out while pulling it, because a part of the shank has a non-thread portion as fall prevention bolt.
- Be careful not to fall off Handle upper [4].

Fig. 22



- 11 Remove Pan head screw M4x35 [1], then remove Clamp [3] from Handle lower [2].
- 12 Remove Power supply cord unit [4] from Clamp [3].

Note

- When removing Pan head screw M4x35 [1], hold Hex nut M4 [5] so that it does not fall off.
- In case Clamp [3] deteriorates and the internal Hex nut M4 [5] falls off, replace Clamp [3].

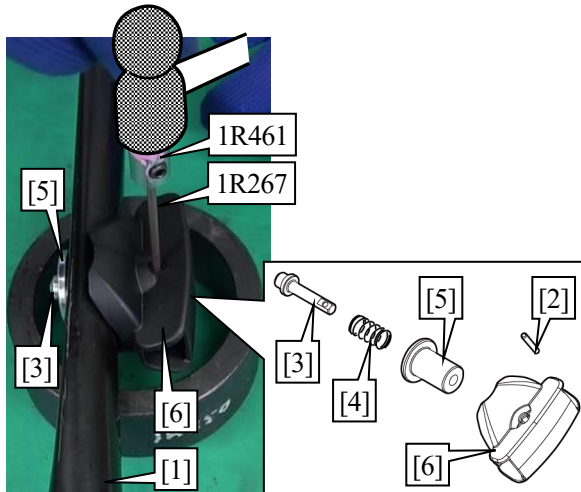
Fig. 23



**13** Remove Hex bolt M8 [1] with Socket bit 13 and an impact driver, then remove Handle lower [2].

**14** Remove Handle lower [2] on the opposite side in the same way.

Fig. 24



**15** Support Handles lower [1] (2 pcs) with an appropriate Ring jig, then punch out Spring pins 2.5-16 [2] (2 pcs) with 1R267, 1R461 and an iron hammer, and then remove the following parts:

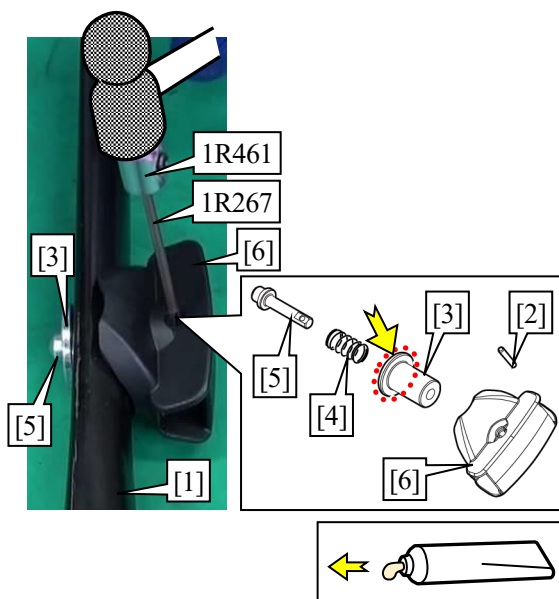
- Lock pins [3] (2 pcs)
- Compression springs 8 [4] (2 pcs)
- Lock holders [5] (2 pcs)
- Knobs [6] (2 pcs)

**Note**

While holding Knobs [6] (2 pcs) and Lock pins [3] (2 pcs) to prevent Lock pins [3] (2 pcs) from popping out, remove Spring pins 2.5-16 [2] (2 pcs).

## 6-3-2 Assembling

Fig. 25



**1** Assemble the following parts to Handle lower [1] (2 pcs), then assemble Spring pins 2.5-16 [2] (2 pcs) with 1R267, 1R461 and an iron hammer.

- Lock holders [3] (2 pcs)
- Compression springs 8 [4] (2 pcs)
- Lock pins [5] (2 pcs)
- Knobs [6] (2 pcs)

**Note**

- While holding and pressing Lock pins [5] (2 pcs), assemble Knobs [6] (2 pcs) by aligning their flats.
- Check the operation of Lock pins [5] (2 pcs) by turning Knobs [6] (2 pcs).
- Apply the specified grease to Lock holders [3] (2 pcs).



Fig. 26

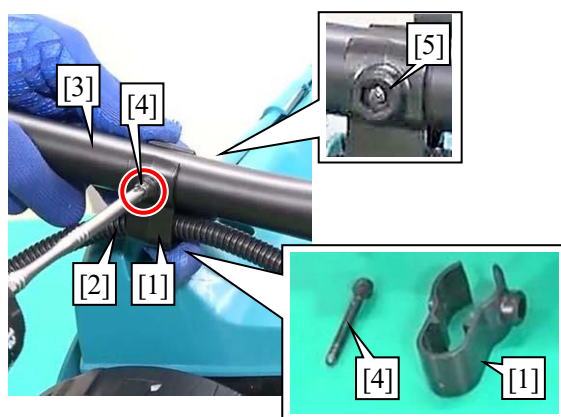


- 2 Assemble Handle lower [2] to Handle bracket R [1], then tighten Hex bolt M8 [3].
- 3 Assemble the opposite side of Handle lower [2] in the same way.

**Tips**

Tighten Hex bolt M8 [3] manually, then tighten it with Socket bit 13 [4] and an impact driver.

Fig. 27

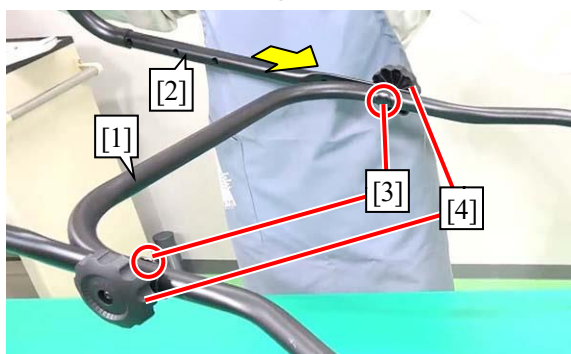


- 4 Pass Power supply cord unit [2] through Clamp [1], then assemble Clamp [1] to Handle lower [3], and then tighten Pan head screw M4x35 [4].

**Note**

- Be careful Hex nut M4 [5] in Clamp [1] does not fall off.
- Assemble Clamp [1] so that Hex nut M4 [5] in Clamp [1] faces toward the machine side.

Fig. 28



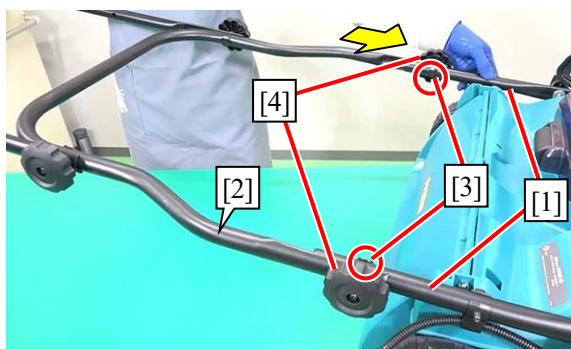
■ When disassembling Handle middle and Handle upper

- 5 Assemble Handle upper [2] to Handle middle [1], then assemble Flat head bolts M8x50 [3] (2 pcs) from the inside, and then tighten Thumb nuts M8 [4] (2 pcs) from the outside.

**Tips**

- Tighten Thumb nut M8 [4] while pressing it to Handle upper [2].
- Assemble Flat head bolt M8x50 [3] so that its saddle shape head fits to the concave of Handle middle [1].

Fig. 29

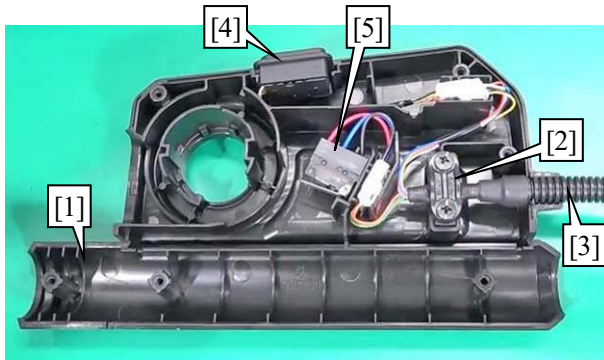


- 6 Assemble Handle middle [2] to Handle lowers [1] (2 pcs), then assemble Flat head bolts M8x50 [3] (2 pcs) from the inside, and then tighten Thumb nuts M8 [4] (2 pcs) from the outside.

**Tips**

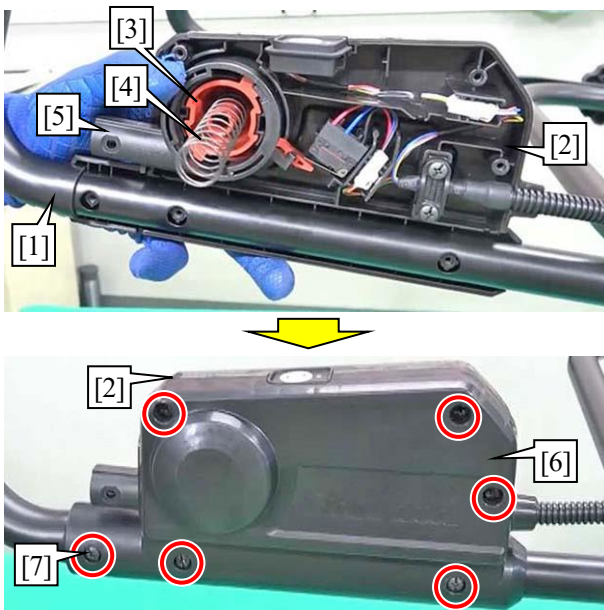
- Tighten Thumb nut M8 [4] while pressing it to Handle middle [2].
- Assemble Flat head bolt M8x50 [3] so that its saddle shape head fits to the concave of Handle lower [1].

Fig. 30



- 7** Assemble the following parts to Switch box L [1]:
- Strain relief [2]
  - Power supply cord unit [3]
  - Switch circuit [4]
  - Switch unit [5]

Fig. 31

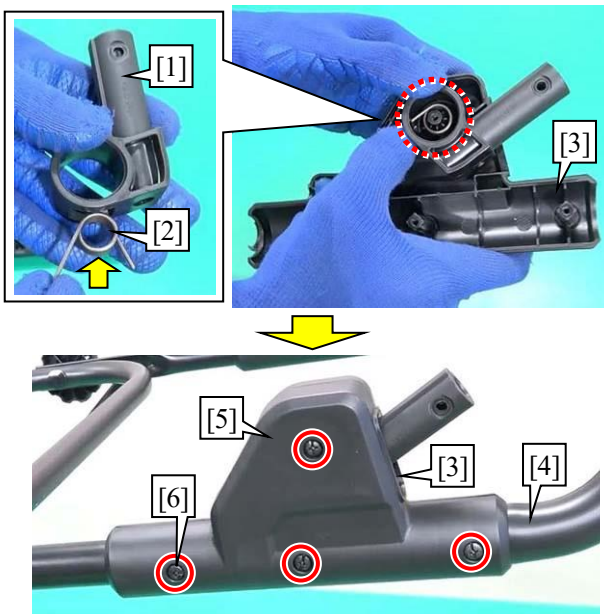


- 8** Assemble Switch box L [2] to Handle upper [1], then assemble the following parts:
- Lock off button [3]
  - Compression spring 15 [4]
  - Switch lever support R [5]
- 9** Assemble Switch box R [6] to Switch box L [2], then tighten Tapping screws 4x20 [7] (6 pcs).

**Note**

The first Tapping screw 4x20 [7] must be tightened while holding Switch box L [2] and Switch box R [6] by hand to prevent them from opening by the tension of Compression spring 15 [4].

Fig. 32



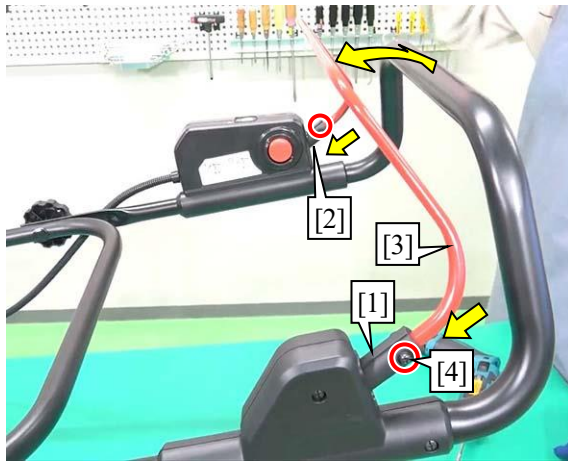
- 10** Assemble Torsion spring 12 [2] to Switch lever support L [1], then assemble them to Lever box R [3].
- 11** Assemble Lever box R [3] and Lever box L [5] to Handle upper [4] with Tapping screws 4x20 [6] (4 pcs).

**Note**

In case assembling Switch lever support L [1] to Lever box R [3], check that Torsion spring 12 [2] is hooked to the screw boss of Lever box R [3].



Fig. 33



- 12 Assemble Switch lever [3] to Switch lever support L [1] and Switch lever support R [2] with P.H.screws M4x20 with WR [4] (2 pcs).

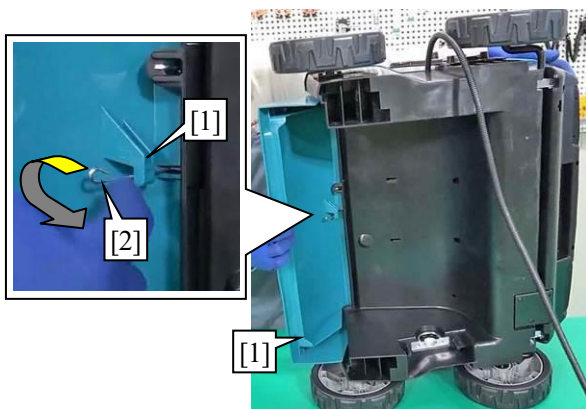
Note

Check that Switch lever [3] works properly.

## 6-4 Cowling section

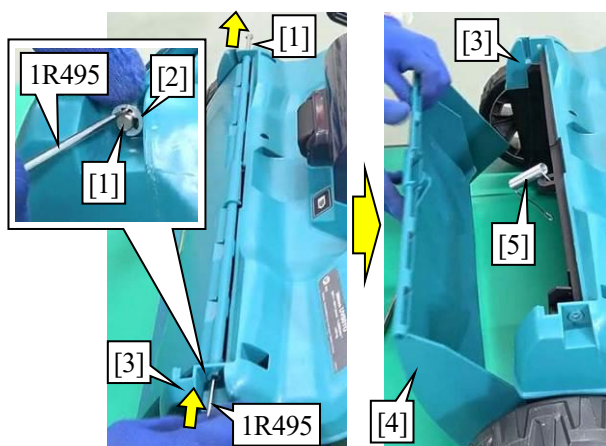
### 6-4-1 Disassembling

Fig. 34



- 1 Stand the machine on its side, then remove the leg of Torsion spring 8 [2] from Rear flap [1].

Fig. 35

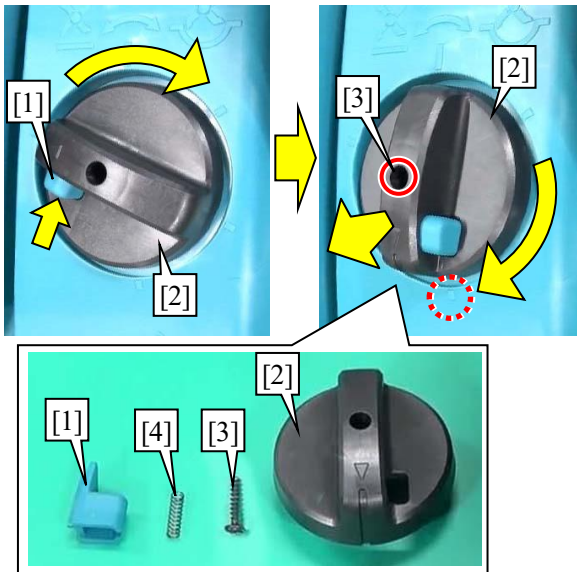


- 2 Remove Stop ring E-5 [2] from Rod 6 [1] with 1R495.
- 3 Push out Rod 6 [1] from Cowling [3] with 1R495, then remove Rear flap [4] and Torsion spring 8 [5].

Tips

Remove Stop ring E-5 [2] on one side only.

Fig. 36

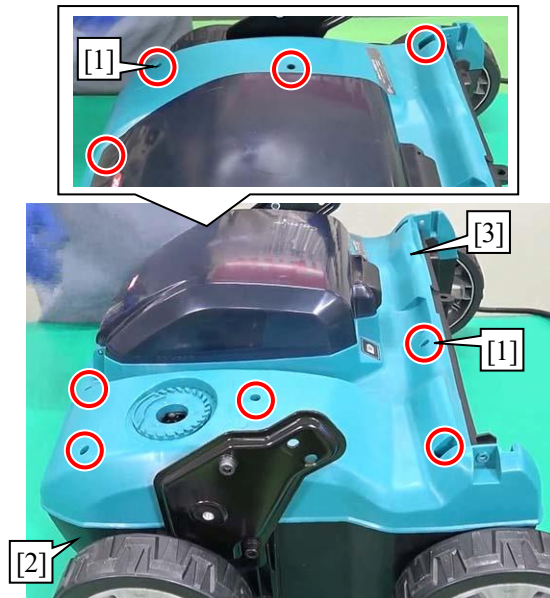


- 4 While pressing Lock off button [1], turn Dial 75 [2] clockwise to set the height of Blade to the lowest position.
- 5 Remove Tapping screw 4x20 [3], then remove Dial 75 [2].
- 6 Remove Lock off button [1] and Compression spring 5 [4] from Dial 75 [2].

**Tips**

In case Compression spring 5 [4] is hard to remove, remove it while turning it.

Fig. 37

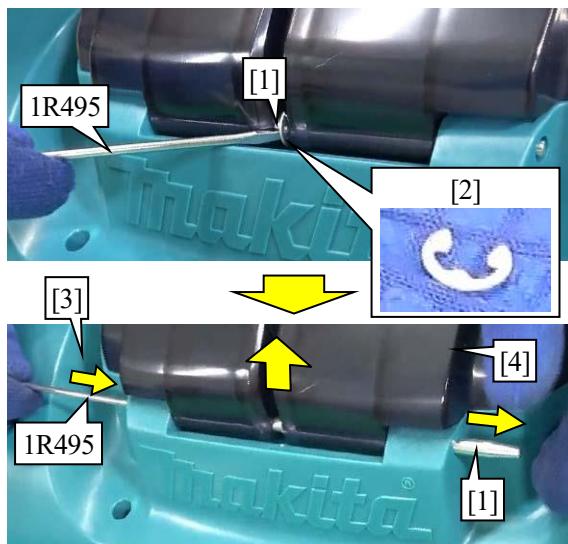


- 7 Remove Tapping screws 4x20 [1] (9 pcs), then remove Cowling [3] from Deck section [2].

**Tips**

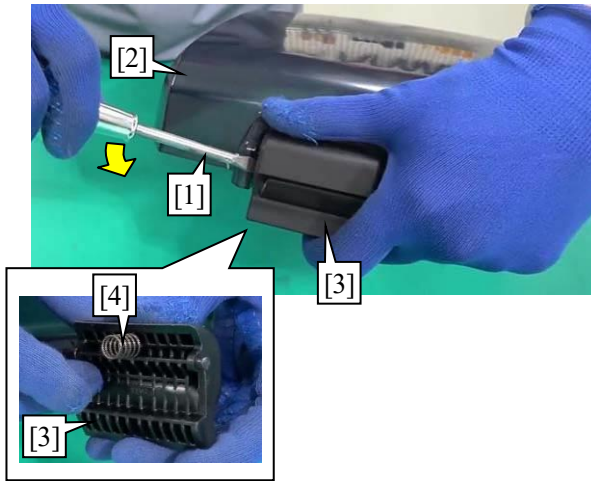
Remove Cowling [3] by lifting it upward so that the whole portions become level.

Fig. 38



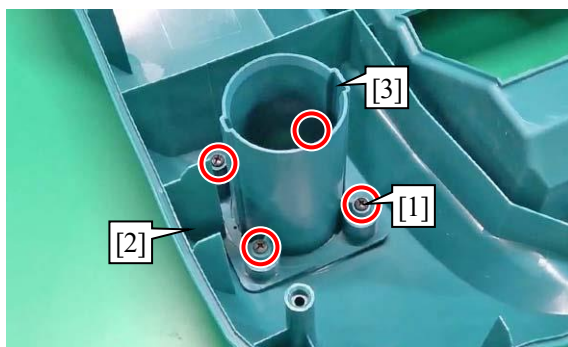
- 8 Remove Stop ring E-5 [2] from Rod 6 [1] with 1R495.
- 9 Push out Rod 6 [1] from Cowling [3] with 1R495, then remove Battery cover [4].

Fig. 39



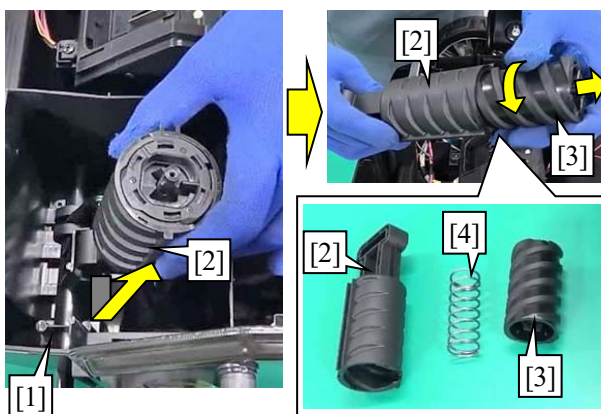
- 10** Remove Lock lever [3] and Compression spring [4] from Battery cover [2] with a slotted screwdriver [1].

Fig. 40



- 11** Remove Tapping screws 4x20 [1] (4 pcs), then remove Holder [3] from Cowling [2].

Fig. 41



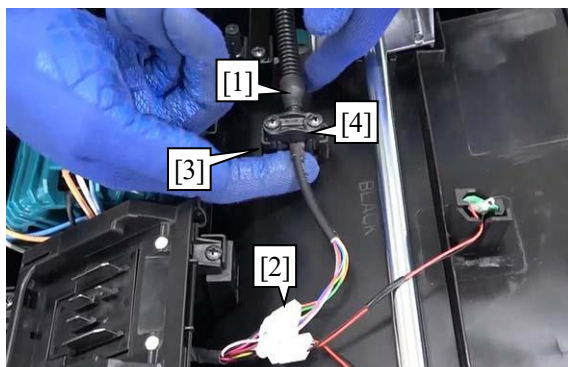
- 12** Remove Adjust screw holder [2] from Deck section [1].

- 13** Remove Adjust screw [3] and Compression spring [4] from Adjust screw holder [2].

**Tips**

- Remove Adjust screw holder [2] by sliding it outward.
- Remove Adjust screw [3] by turning it counterclockwise.

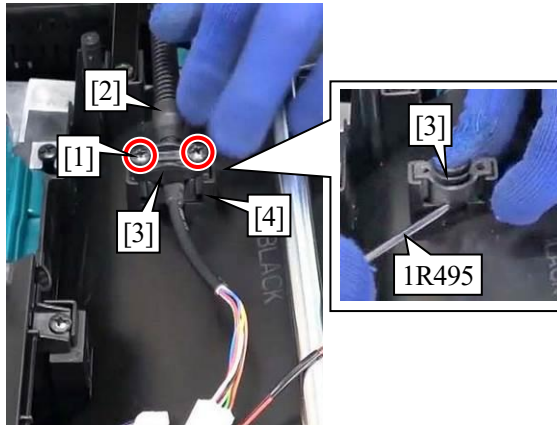
Fig. 42



- 14** Disconnect Connector [2] of Power supply cord unit [1], then remove the unit of Power supply cord unit [1] and Strain relief [4] from Deck section [3].



Fig. 43



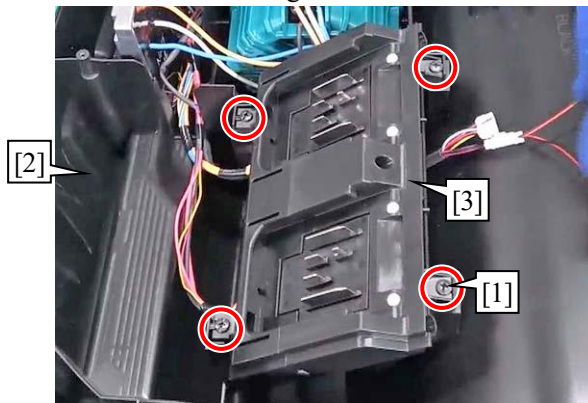
■ When disassembling Power supply cord unit

- 15 Remove Tapping screws 4x20 [1] (2 pcs), then remove Strain relief [3] from Power supply cord unit [2].

Note

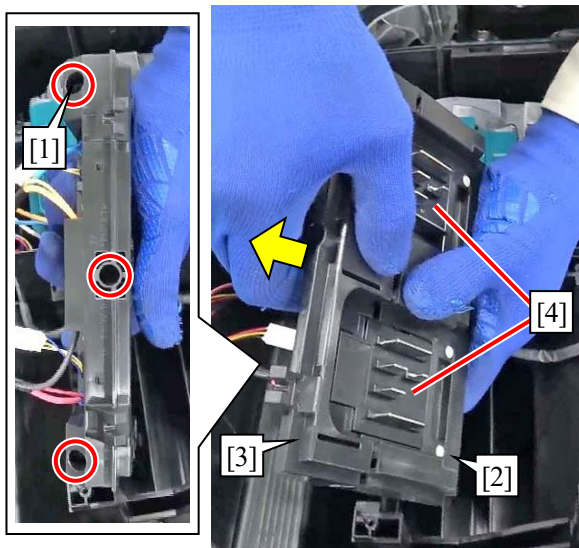
- Be sure to remove Tapping screw 4x20 [1] with Strain relief [3] assembled to Deck section [4].
- In case the lower side of Strain relief [3] is hard to remove, lift it up with 1R495.

Fig. 44



- 16 Remove Tapping screws 4x20 [1] (4 pcs), then remove Terminal housing section [3] from Deck section [2].

Fig. 45

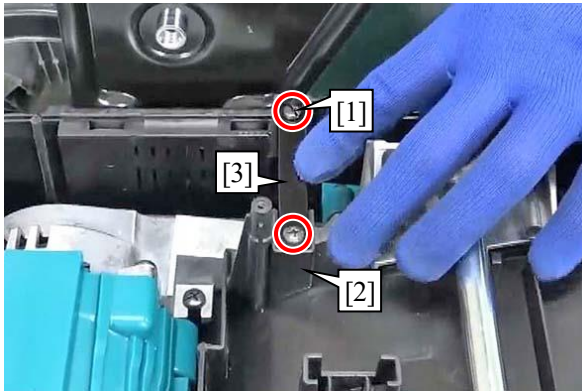


- 17 Remove Tapping screws 4x20 [1] (3 pcs), then remove Terminal housing F [3] and Terminal units [4] (2 pcs) from Terminal housing R [2].

Note

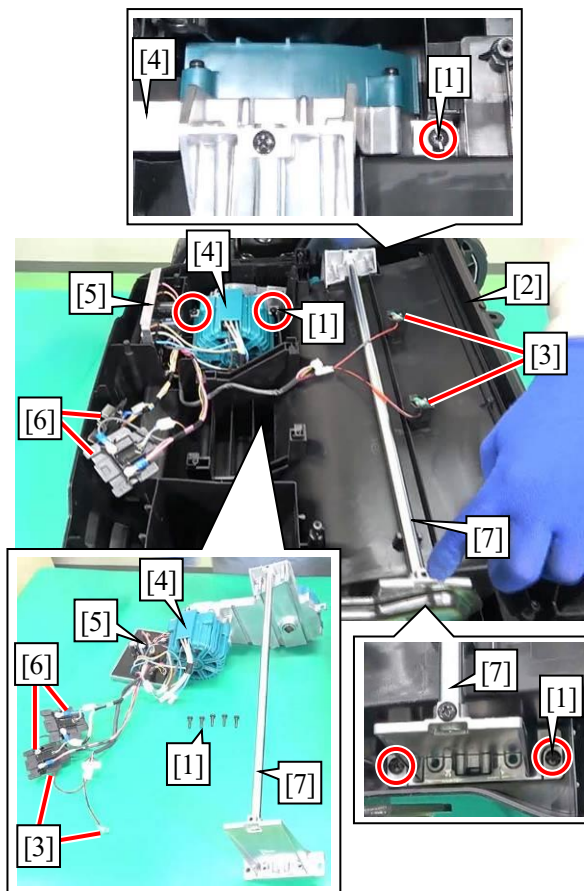
Replace Terminal housing R [2] and Terminal housing F [3] as a set.

Fig. 46



18 Remove Tapping screws 4x20 [1] (2 pcs), then remove Plate [3] from Deck section [2].

Fig. 47



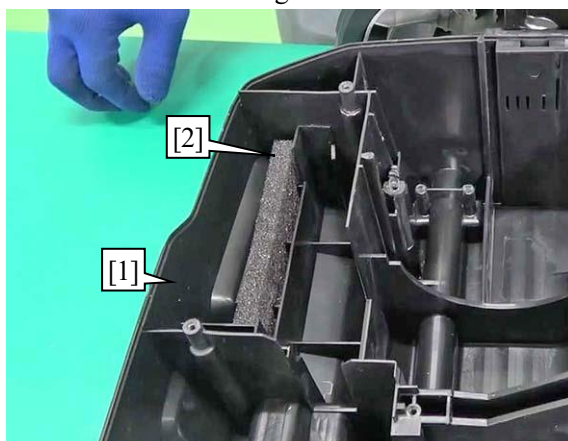
19 Remove Tapping screws 5x20 [1] (5 pcs), then remove the following parts as a unit from Deck section [2]:

- LED circuits [3] (2 pcs)
- Motor section [4]
- Controller [5]
- Terminal units [6] (2 pcs)
- Shaft section [7]

Note

Lift up and remove the unit so that the whole portions become level to prevent Shaft portion from twisting.

Fig. 48



20 Remove Sponge [2] from Deck section [1].

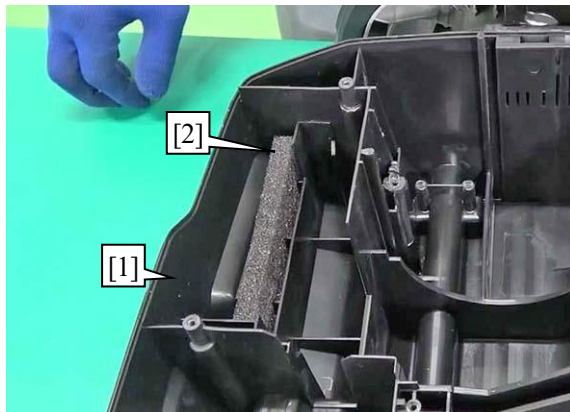
Note

In case Sponge [2] deteriorates, replace it.



## 6-4-2 Assembling

Fig. 49

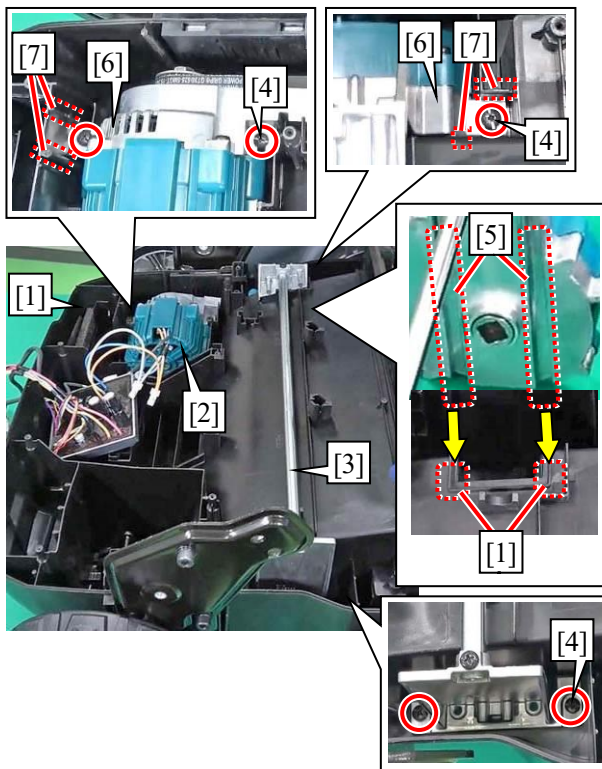


- 1 Assemble Sponge [2] to Deck section [1].

### Tips

In case Sponge [2] is dirty, clean it with an air duster or the like before assembling it.

Fig. 50

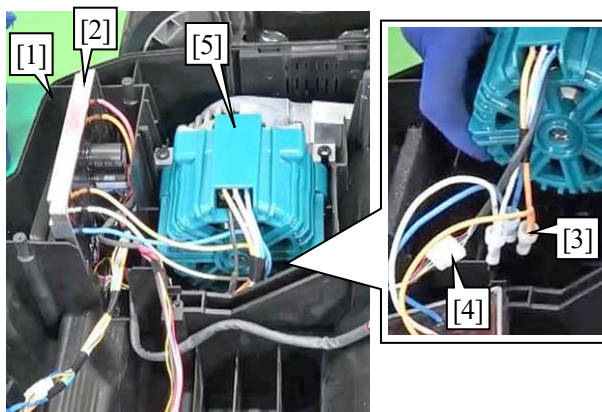


- 2 Assemble Motor section [2] and Shaft section [3] as a unit to Deck section [1], then tighten Tapping screws 5x20 [4] (5 pcs).

### Tips

- Align the grooves (2 positions) of Pulley holder [5] with the ribs of Deck section [1], then assemble Motor section [2] and Shaft section [3] in the horizontal position.
- Assemble Pulley holder [6] so that its both ends fit to the ribs [7] of Deck.

Fig. 51

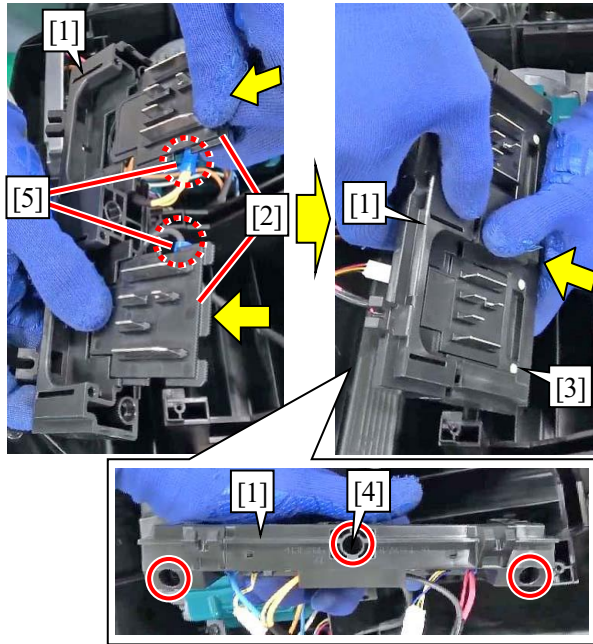


- 3 Assemble Controller [2] to Deck section [1], then put Lead wires of Closed end splices [3] (3 pcs) and Connector [4] in place.

### Tips

- Assemble Controller [2] with the thin lead wires facing downward.
- Put Lead wires of Closed end splices [3] (3 pcs) and Connector [4] in the gap between Deck section [1] and Motor section [5].

Fig. 52



- 4 Assemble Terminal units [2] (2 pcs) and Terminal housing R [3] to Terminal housing F [1], then tighten Tapping screws 4x20 [4] (3 pcs).

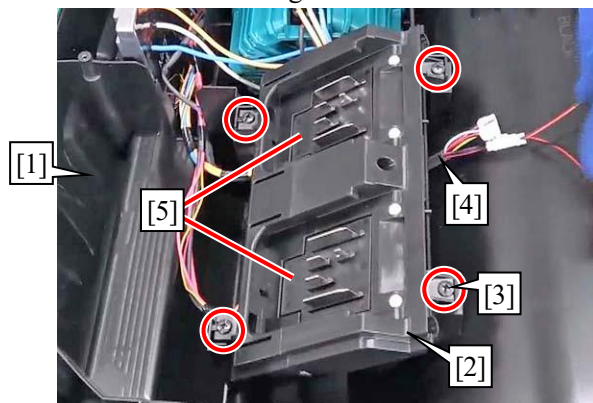
**Tips**

Assemble Terminal unit [2] so that the lateral terminal portions [5] face toward the inside.

**Note**

Be careful not to pinch the lead wires of Terminal unit [2] (2 pcs) before tightening Tapping screws 4x20 [4] (3 pcs).

Fig. 53

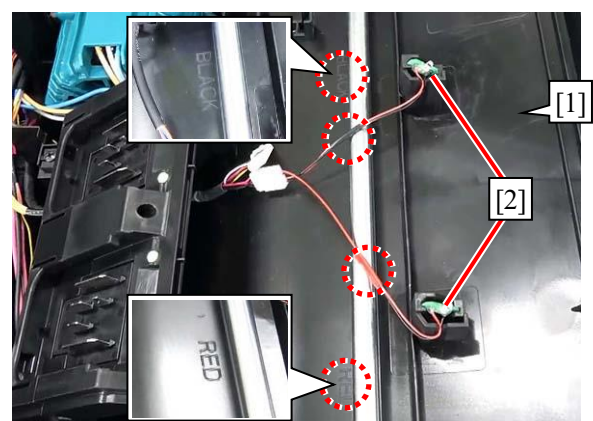


- 5 Assemble Terminal housing section [2] to Deck section [1], then tighten Tapping screws 4x20 [3] (4 pcs).

**Note**

- Route LED circuit lead wires under Terminal housing section [2] and assemble them.
- Be careful not to forget to reuse Serial number label to the new Terminal unit [5] in case of replacing Terminal unit [5].

Fig. 54

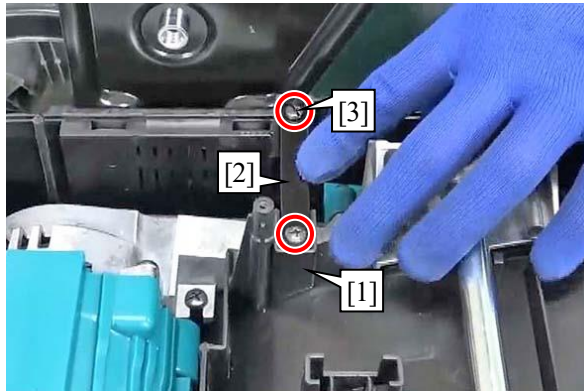


- 6 Assemble LED circuits [2] (2 pcs) to Deck section [1].

**Tips**

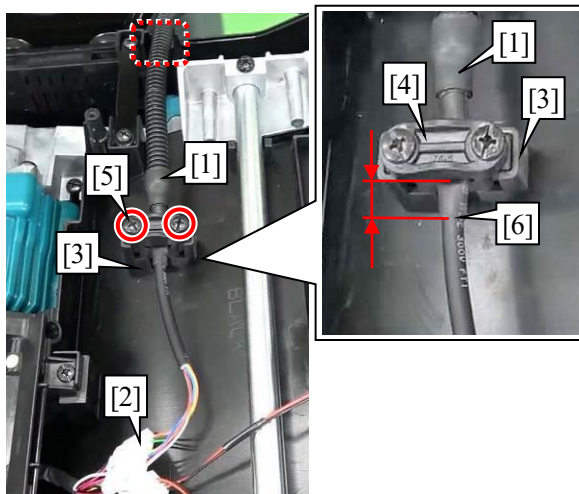
Match the "RED" and "BLACK" marks on Deck section [1] with the tape colors wrapped around LED circuit lead wires [2].

Fig. 55



- 7 Assemble Plate [2] to Deck section [1] with Tapping screws 4x20 [3] (2 pcs).

Fig. 56

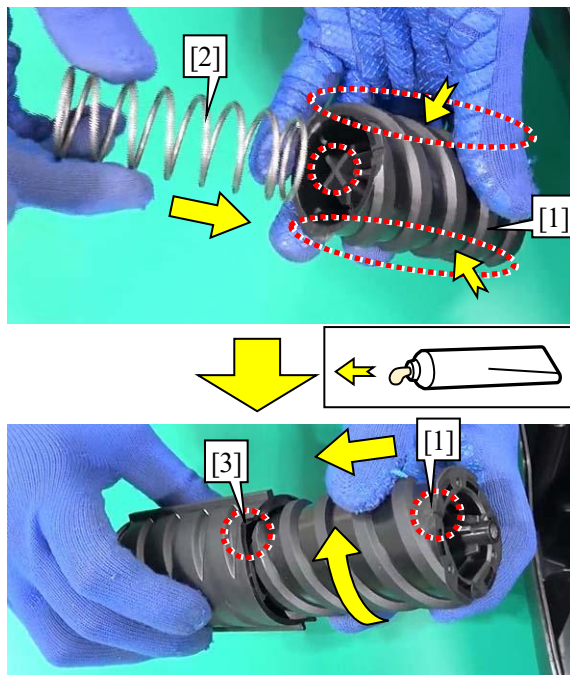


- 8 Connect Connector [2] of Power supply cord unit [1].
- 9 Assemble Power supply cord unit [1] and Strain relief [4] to Deck section [3], then tighten Tapping screws 4x20 [5] (2 pcs).

Note

- Assemble Power supply cord unit [1] so that the top end of sheath section [6] protrudes 3mm to 8mm from Strain relief [4].
- Assembling Strain relief [4] with it attached to Deck section [3].

Fig. 57



- 10 Assemble Compression spring 23 [2] to the cross-shaped protrusion of Adjust screw [1], then assemble them to Adjust screw holder [3].

Tips

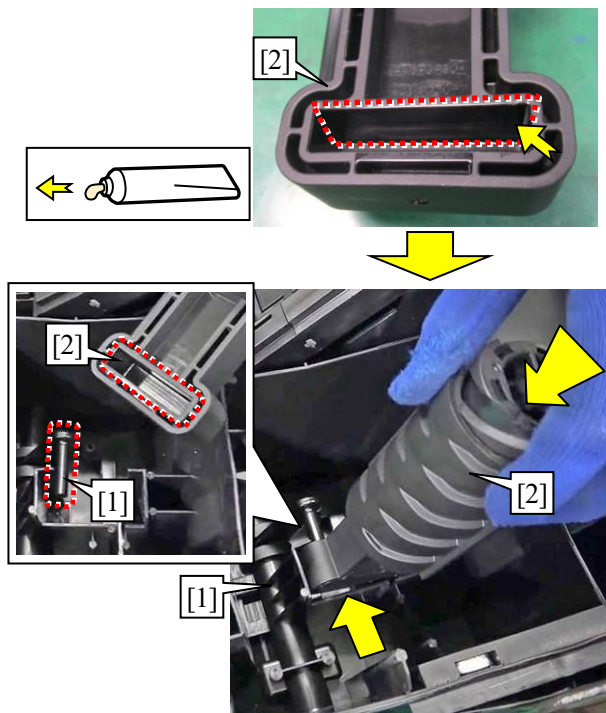
Align the notch of Adjust screw holder [3] with the groove of Adjust screw [1], then assemble them by turning Adjust screw [1] clockwise.

Note

Apply the specified grease to Adjust screw [1].



Fig. 58



**11** Assemble Adjust screw holder [2] to Deck section [1].

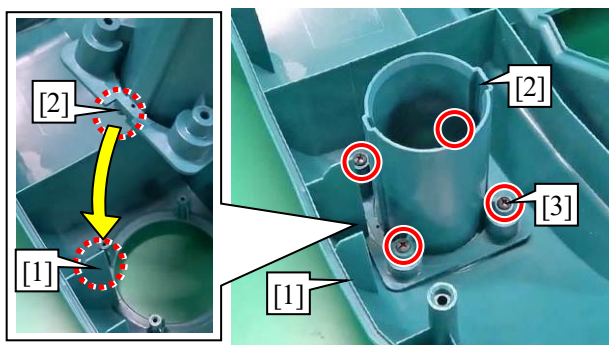
**Tips**

Align the pin of Deck section [1] with the groove of Adjust screw holder [2].

**Note**

Apply the specified grease to the inside of groove of Adjust screw holder [2].

Fig. 59

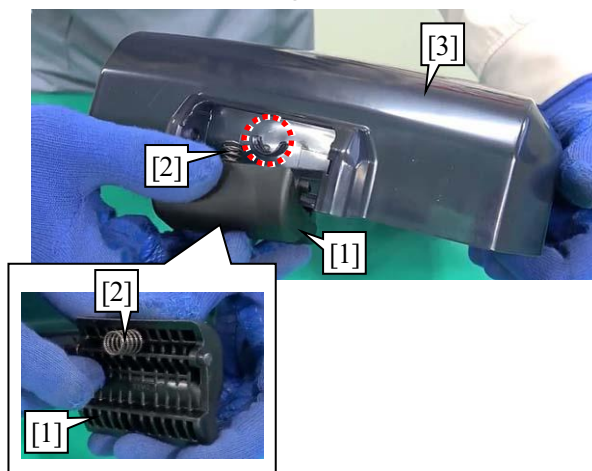


**12** Assemble Holder [2] to Cowling [1] with Tapping screws 4x20 [3] (4 pcs).

**Tips**

Align the ribs of Cowling [1] with the notches of Holder [2], then assemble them.

Fig. 60



**13** Assemble Compression spring 7 [2] to Lock lever [1], then assemble Lock lever [1] to Battery cover [3].

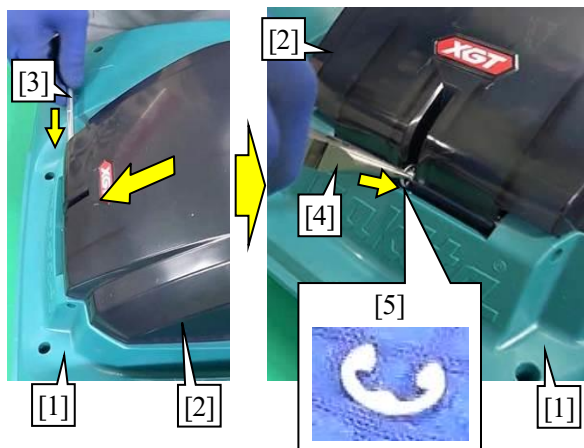
**Tips**

Assemble Compression spring 7 [2] to the semicircular portion of Battery cover [3].

**Note**

Check that Lock lever [1] works properly.

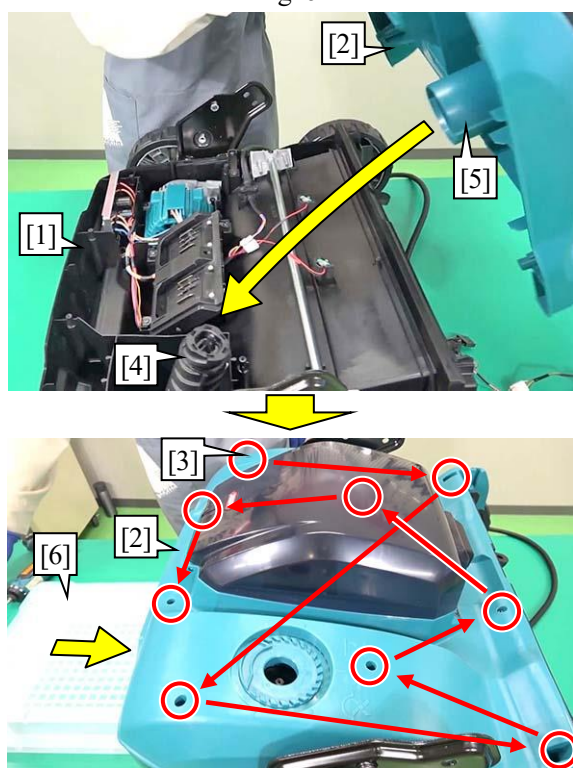
Fig. 61



**14** Assemble Battery cover [2] to Cowling [1], then insert Rod 6 [3] into them.

**15** Assemble Stop ring E-5 [5] with long-nose pliers [4].

Fig. 62



**16** Assemble Cowling [2] to Deck section [1], then tighten Tapping screws 4x20 [3] (9 pcs).

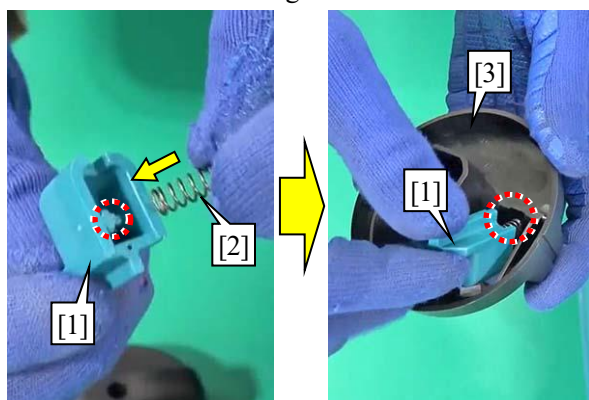
**Tips**

- Align Adjust screw holder [4] with Holder [5], then assemble them.
- Tighten Tapping screws 4x20 [3] from the outside (4 positions) of Cowling [2], then tighten the inside (5 positions), because the end of Cowling [2] tends to lift up.

**Note**

- Support the top portion of Deck section [1] with a box [6] or wood, then assemble Cowling [2] with Adjust screw is lowered most.
- Check that Cowling [2] is assembled without any gap, then tighten Tapping screw 4x20 [3].
- Tighten Tapping screw 4x20 [3] in order from the upper left corner, then remove a box [6] or a wood after tightening.

Fig. 63



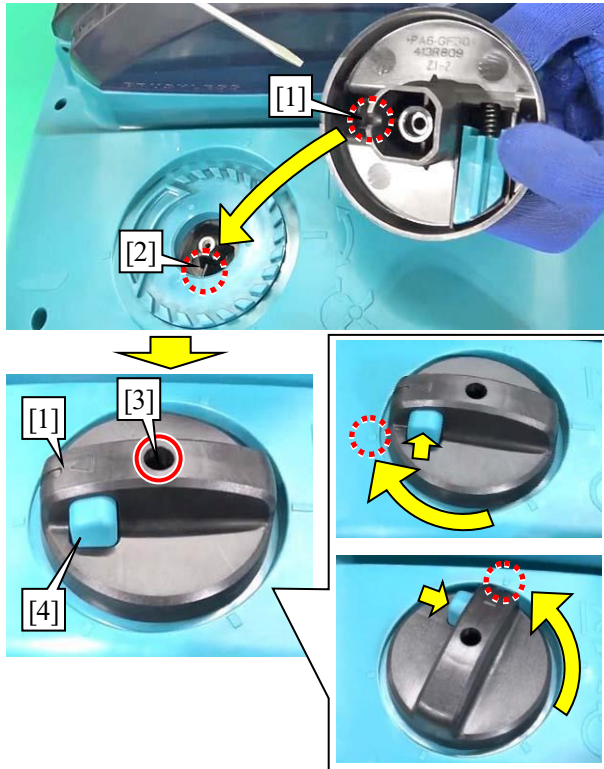
**17** Assemble Compression spring 5 [2] to Lock off button [1], then assemble them to Dial 75 [3].

**Tips**

- Assemble Compression spring 5 [2] to the cross-shaped protrusion of Lock off button [1].
- In case Compression spring 5 [2] is hard to assemble, rotate it to assemble.
- Align the groove of Dial 75 [3] with Compression spring 5 [2], then assemble them.



Fig. 64

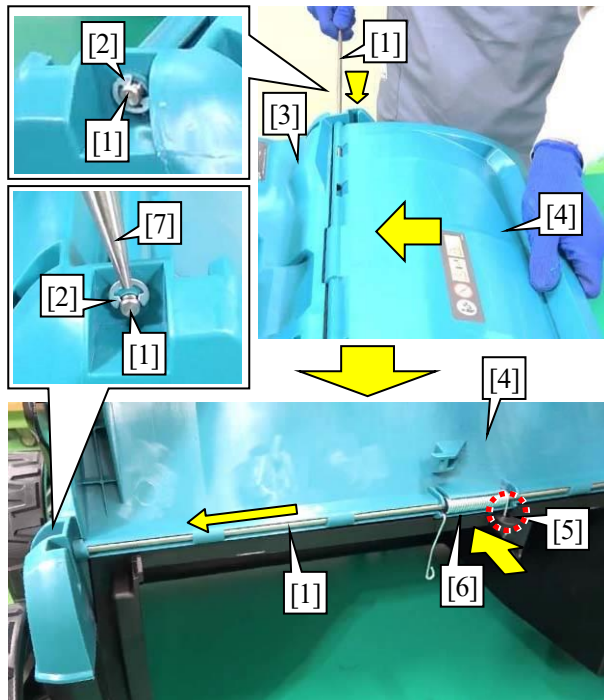


- 18** Align the slit of Dial 75 [1] with the rib of Adjust screw [2] to assemble them, then tighten Tapping screw 4x20 [3].

**Note**

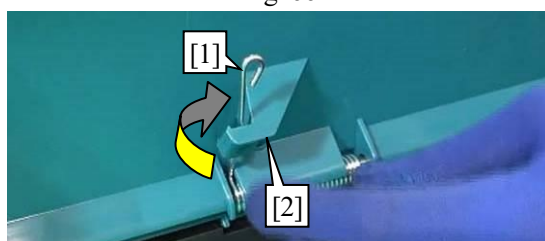
While pressing Lock off button [4], check the position of mark is correct when the machine is lowered most by turning Dial 75 [1] clockwise, then check the position of mark is correct when the machine is raised most by turning Dial 75 [1] counterclockwise.

Fig. 65



- 19** Assemble Stop ring E-5 [2] to one side of Rod 6 [1].
- 20** Assemble Rear flap [4] to Cowling [3], then insert Rod 6 [1] halfway.
- 21** Insert the shorter leg of Torsion spring 8 [6] into the hole of Deck [5], then assemble Torsion spring 8 [6] to Rear flap [4].
- 22** Insert the whole of Rods 6 [1], then assemble Stop ring E-5 [2] to the other side of Rod 6 [1] with long-nose pliers [7].

Fig. 66

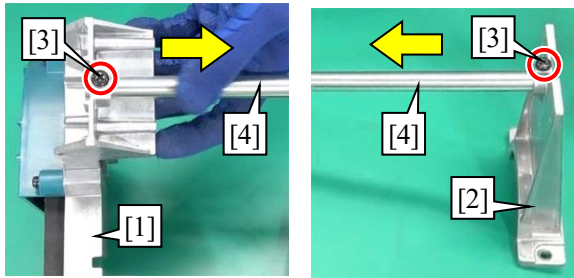


- 23** Assemble the longer leg of Torsion spring 8 [1] to Rear flap [2].

## 6-5 Motor section

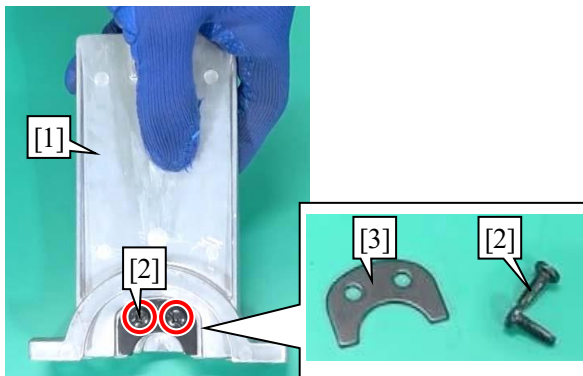
### 6-5-1 Disassembling

Fig. 67



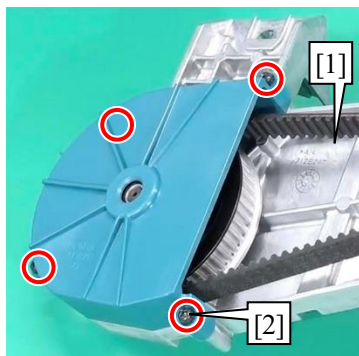
- 1 Remove + Pan head screws M5 [3] (2 pcs) from Motor section [1] and Shaft holder [2], then remove Shaft 12 [4].

Fig. 68



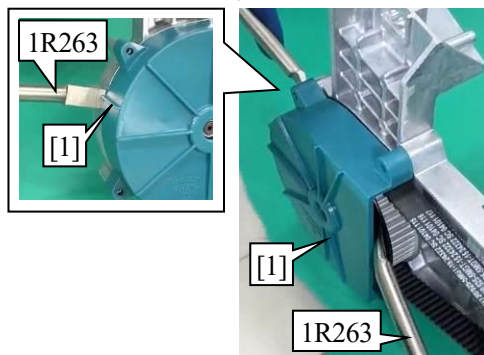
- 2 Remove Tapping screws bind CT 4x12 [2] (2 pcs) from Shaft holder [1], then remove Bearing retainer [3].

Fig. 69



- 3 Remove P.H.screws M4x16 with WR [2] (4 pcs) from Motor section [1].

Fig. 70

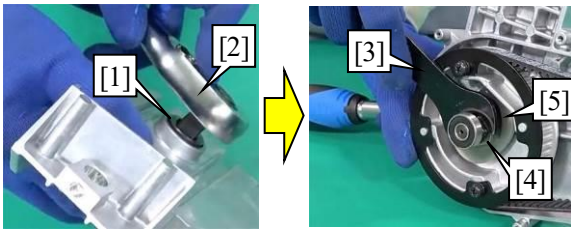


- 4 Remove Bearing cover [1] with 1R263 (2 pcs).

#### Tips

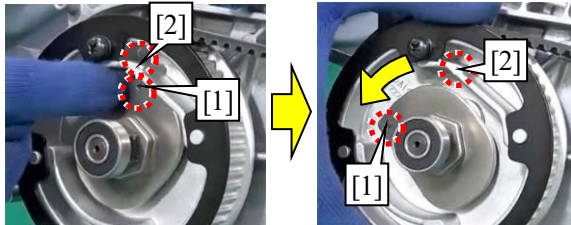
Set 1R263 (2 pcs) to the rib position of Bearing cover [1] and Pulley side on opposite side, then remove Bearing cover [1].

Fig. 71



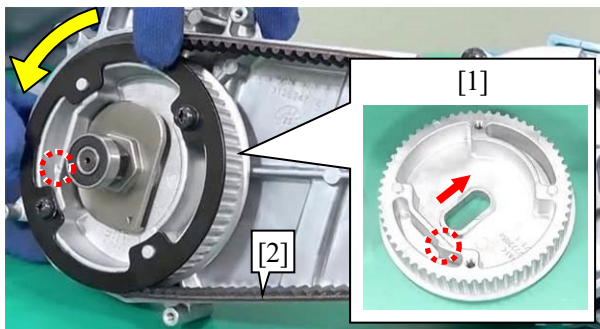
- 5 Set a 1/2-inch ratchet handle [2] on Shaft 17 [1] to prevent rotating.
- 6 Slightly loosen Hex nut M10 [4] with Wrench 17 [3] to make Eccentric disk [5] free.

Fig. 72



- 7 Turn and shift Eccentric disk [1] from the position where the top end of the arrow of Eccentric disk [1] is aligned with the top end of the arrow of Pulley 60 [2].

Fig. 73

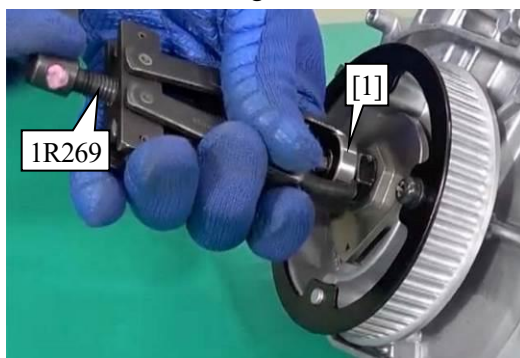


- 8 Turn Pulley 60 [1] to turn the arrow position outward, then loosen Synchro belt 15-525 [2], and then remove Synchro belt 15-525 [2].

**Tips**

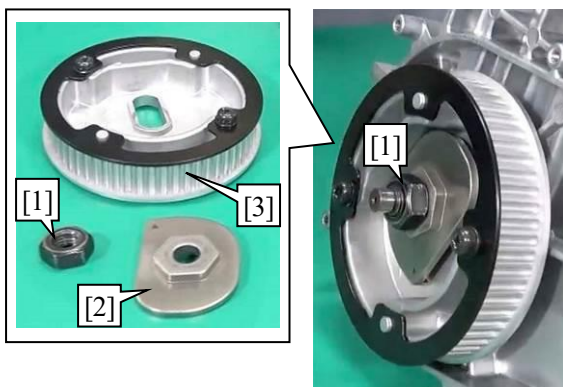
The direction of the arrow and the oblong hole direction of Pulley 60 [1] are aligned with each other, so turning Pulley 60 [1] turns the long hole direction from vertical to horizontal, and then moving it toward the inside allows Synchro belt 15-525 [2] to be loosened.

Fig. 74



- 9 Remove Ball bearing 608DDW [1] with 1R269.

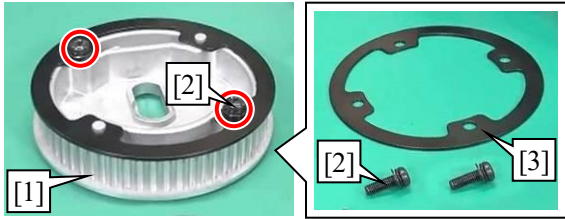
Fig. 75



- 10 Remove Hex nut M10 [1], then remove Eccentric disk [2] and Pulley 60 [3].

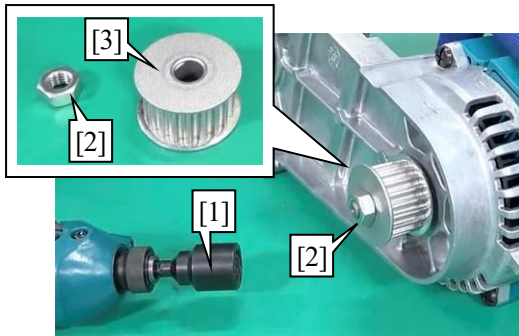


Fig. 76



- 11 Remove Pan head screws M5x16 [2] (2 pcs) from Pulley 60 [1], then remove Pulley plate 30 [3].

Fig. 77

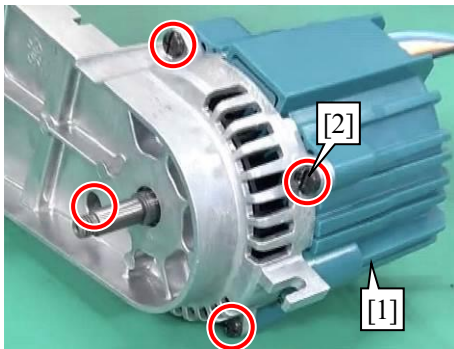


- 12 Remove Hex nut M8-13 [2] by turning it clockwise with Socket bit 13 [1] and an impact driver, then remove Pulley 20 [3].

Note

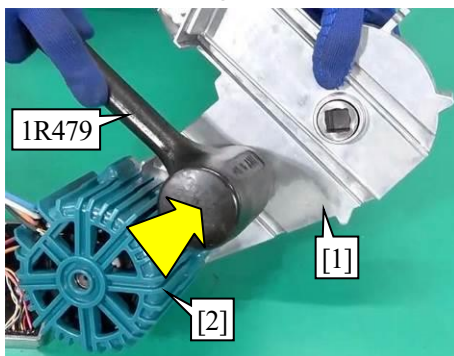
Be careful with the turning direction of Hex nut M8-13 [2] because it is left-handed.

Fig. 78



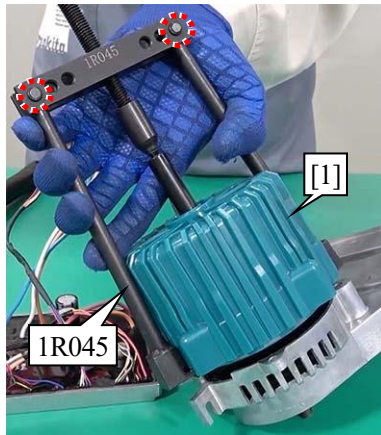
- 13 Remove Tapping screws 5x20 [2] (4 pcs) from Motor housing [1].

Fig. 79



- 14 Lift up Motor housing [2] by tapping Pulley holder [1] with 1R479.

Fig. 80

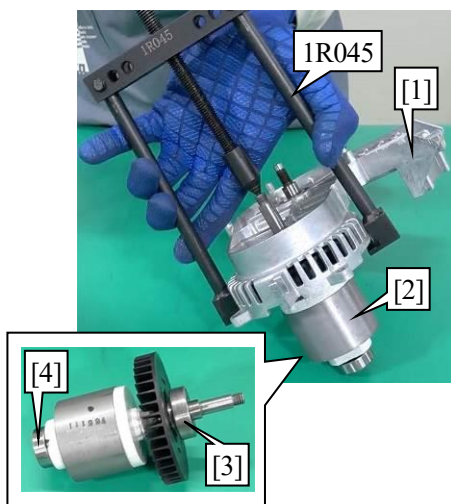


**15** Remove Motor housing [1] with 1R045 and an appropriate Pin jig.

**Tips**

- Set each jaw of 1R045 to each outside hole among three holes.
- Pull out Motor housing [1] firmly by tightening 1R045 until Rotor is separated because it has strong magnetic force.

Fig. 81

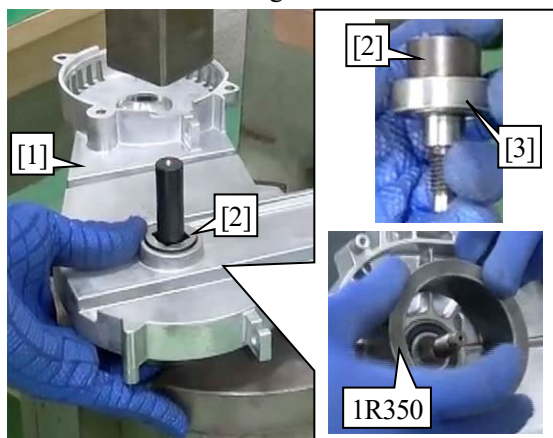


**16** Remove Rotor [2] from Pulley holder [1] with 1R045.

**Note**

Replace Ball bearing 6201DDW [3] and Ball bearing 6000DDW [4] on the front side and the rear side of Rotor [2] if necessary.

Fig. 82



**17** Support Pulley holder [1] with 1R350, then push out Shaft 17 [2] and Ball bearing 6003LLU [3] with Arbor press and an appropriate Pin jig.

**Tips**

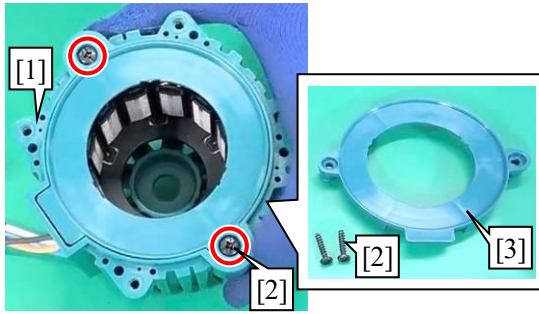
Support Pulley holder [1] so that its balance does not collapse, then hold it so that it does not fall off when pushed out, and then push out Shaft 17 [2] and Ball bearing 6003LLU [3].

**Note**

- Be careful not to fall off Shaft 17 [2] and Ball bearing 6003LLU [3].
- Replace Ball bearing 6003LLU [3] if necessary.

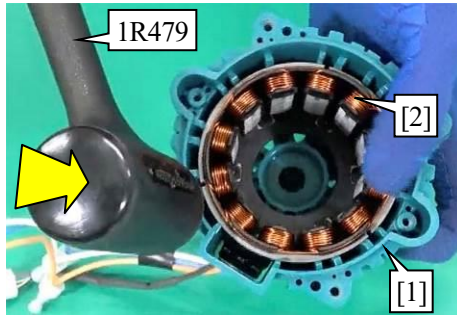


Fig. 83



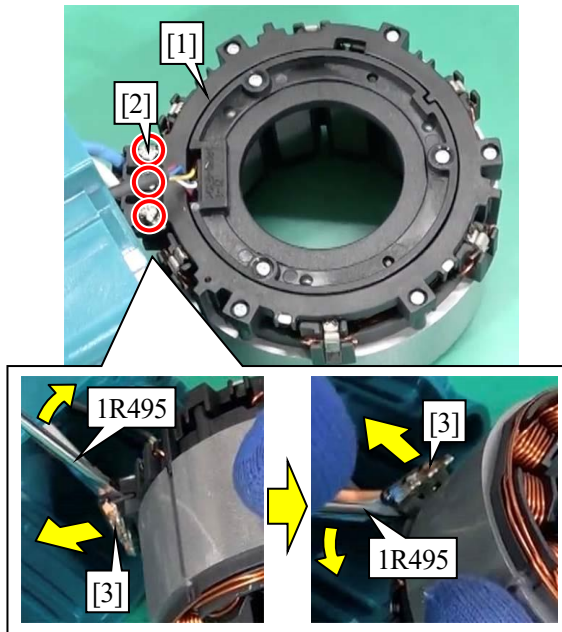
18 Remove Tapping screws 4x20 [2] (2 pcs) from Motor housing [1], then remove Baffle plate [3].

Fig. 84



19 Remove Stator [2] by tapping Motor housing [1] with 1R479.

Fig. 85

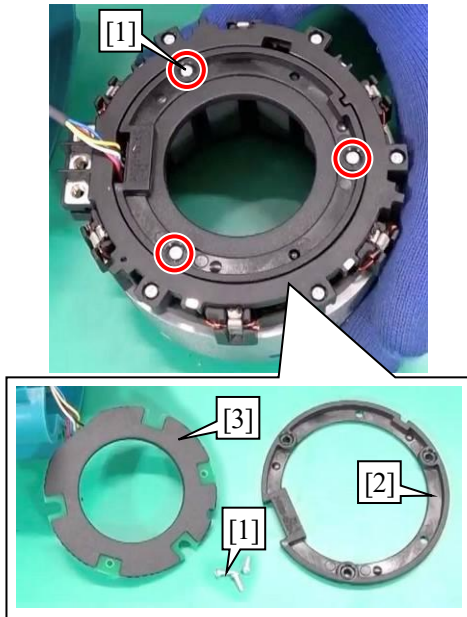


20 Remove Pan head screws M3x6 [2] (3 pcs) from Stator [1], then remove Lead unit [3] with 1R495.

**Tips**

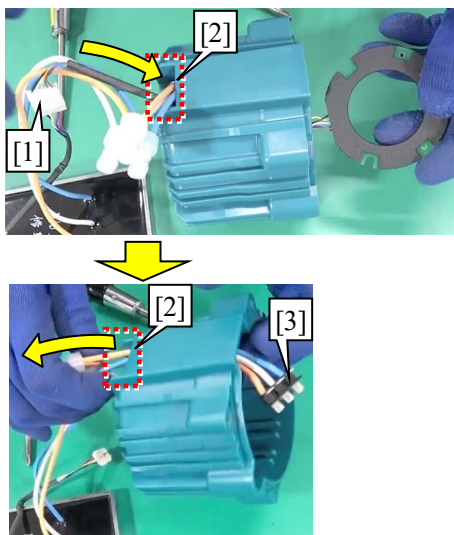
Lead unit [3] has tabs on the back side. Therefore, lift up the lower side of both ends with 1R495 and remove Lead unit [3] outward.

Fig. 86



- 21** Remove Tapping screws PT 2x6 [1] (3 pcs) with a No.1 Phillips screwdriver, then remove Stopper [2] and Controller B [3].

Fig. 87

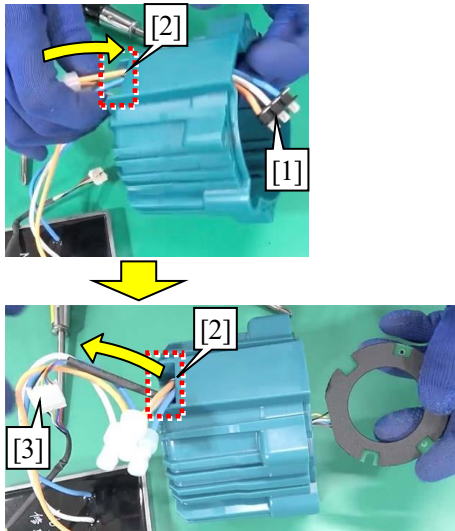


- 22** Disconnect Connector of Controller B [1], then remove it through the groove of Motor housing [2].
- 23** Remove Lead unit [3] through the groove of Motor housing [2].

## 6-5-2 Assembling

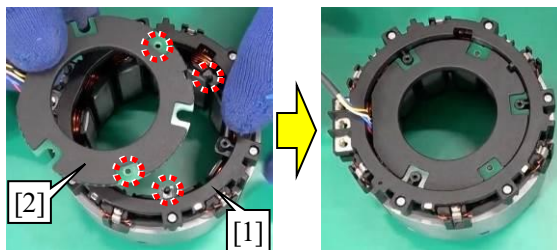
- 1 Assemble the electrical parts in accordance with Circuit diagram and Wiring diagram.

Fig. 88



- 2 Pass Lead unit [1] through the groove of Motor housing [2].
- 3 Pass Connector of Controller B [3] through the groove of Motor housing [2], then connect Connector of Controller B [3].

Fig. 89

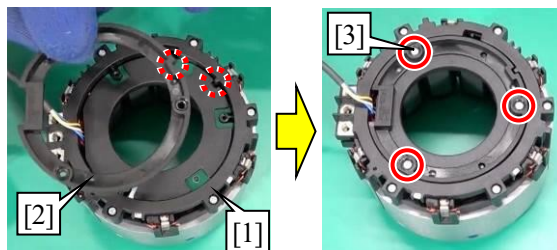


- 4 Assemble Controller B [2] to Stator [1].

**Tips**

With the green side of Controller B [2] facing upward, assemble Controller B [2] to Stator [1] by aligning the two pins of Stator [1] with the two holes of Controller B [2].

Fig. 90

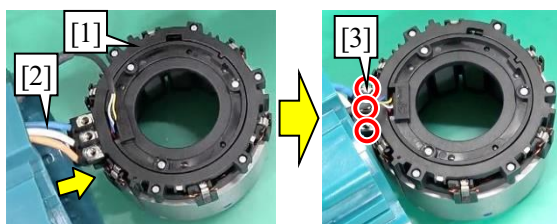


- 5 Assemble Stopper [2] to Stator [1], then tighten Tapping screws PT 2x6 [3] (3 pcs) with a No.1 Phillips screwdriver.

**Tips**

- Align the protrusion of Stator [1] with the notch of Stopper [2], then assemble them.
- Assemble Stopper [2] with its flat side facing downward.

Fig. 91

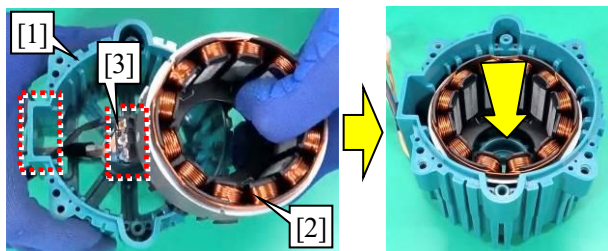


- 6 Assemble Lead unit [2] to Stator [1] with Pan head screws M3x6 [3] (3 pcs).

**Tips**

Assemble Lead unit [2] with the metal facing upward.

Fig. 92

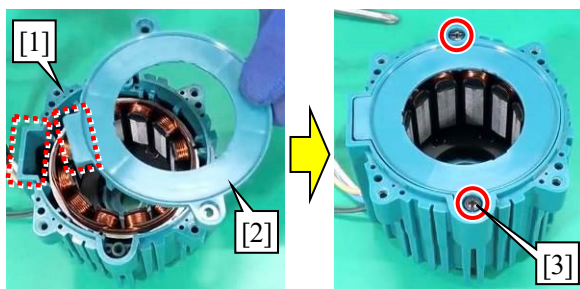


7 Assemble Stator [2] to Motor housing [1].

**Tips**

Face the stopper side of Stator [2] downward, then align the position of the square groove of Motor housing [1] with Lead unit [3], and then insert Stator [2] into the bottom.

Fig. 93

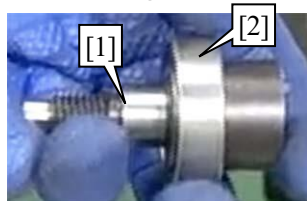


8 Assemble Baffle plate [2] to Motor housing [1] with Tapping screws 4x20 [3] (2 pcs).

**Tips**

Face the pin side of Baffle plate [2] toward Stator side, then assemble Baffle plate [2] by aligning its square shape with the groove of Motor housing [1].

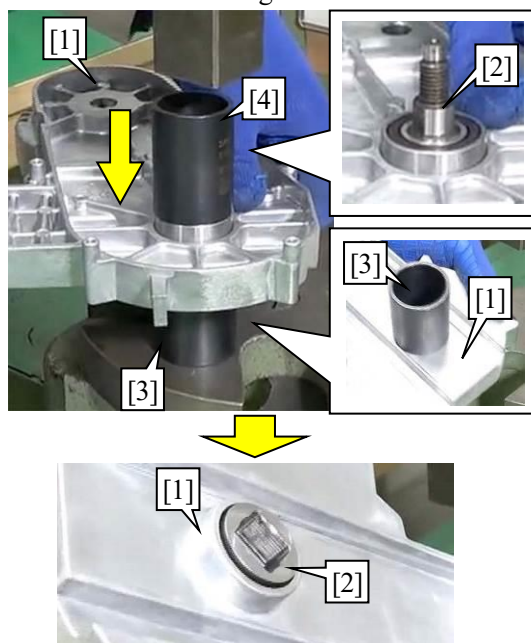
Fig. 94



■ In case of removing Ball bearing 6003LLU

9 Assemble Ball bearing 6003LLU [2] to Shaft 17 [1].

Fig. 95



10 Assemble Shaft 17 [2] to Pulley holder [1].

11 Support Pulley holder [1] with an appropriate Pipe jig [3], then press-fit Shaft 17 [2] with an appropriate Pipe jig [4].

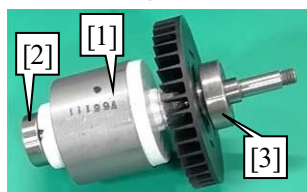
**Tips**

Assemble Shaft 17 [2] so that its square groove protrudes to the outside of Pulley holder [1].

**Note**

- Support the flat side of Pulley holder [1] with an appropriate Pipe jig [3], then check that it does not touch the ribs on both sides.
- After press-fitting, check that Shaft 17 [2] slightly protrudes from Pulley holder [1].

Fig. 96



■ In case of removing Ball bearing 6000 DDW and 6201DDW

12 Assemble Ball bearing 6000DDW [2] and Ball bearing 6201DDW [3] to Rotor [1].

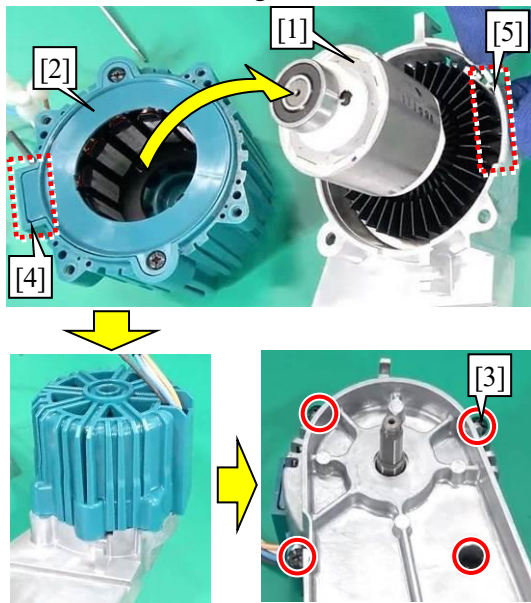


Fig. 97



13 Press-fit Rotor [2] into Pulley holder [1].

Fig. 98

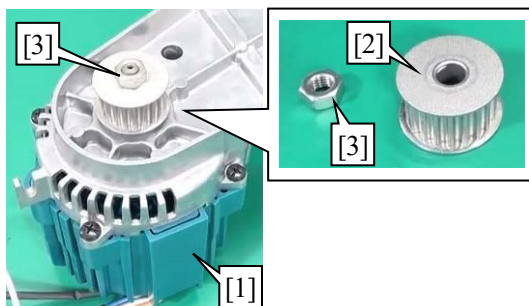


14 Assemble Stator [2] to Rotor [1], then tighten Tapping screws 5x20 [3] (4 pcs).

**Tips**

- In case Stator [2] is assembled to Rotor [1], the screw holes tends to deviate. Therefore, align the screw holes.
- Align the square shape of Motor housing [4] with the wide groove of Pulley holder [5], then assemble them.

Fig. 99



15 Assemble Pulley 20 [2] to Motor section [1], then temporarily tighten Hex nut M8-13 [3] by turning it counterclockwise.

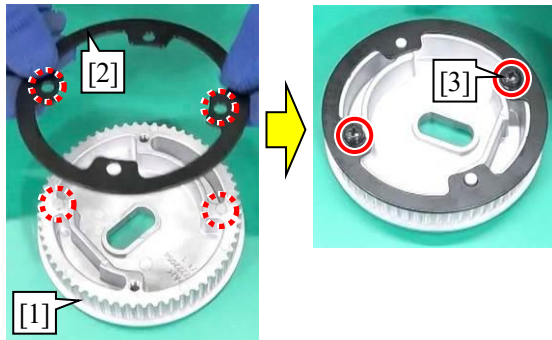
**Tips**

Tighten Hex nut M8-13 [3] firmly after assembling Synchro belt.

**Note**

- Be careful with the turning direction of Hex nut M8-13 [3] because it is left-handed.
- Assemble Pulley 20 [2] so that the side marked with the part number faces downward.

Fig. 100

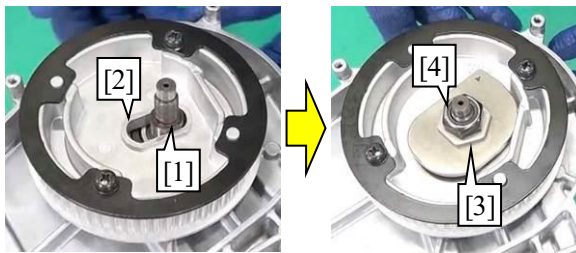


- 16** Assemble Pulley plate 30 [2] to Pulley 60 [1], then tighten Pan head screws M5x16 [3] (2 pcs).

**Tips**

Align the four holes of Pulley plate 30 [2] so that diagonal two holes on Pulley plate 30 fit to the pins of Pulley 60 [1] and the other two holes fit the holes of Pulley 60.

Fig. 101



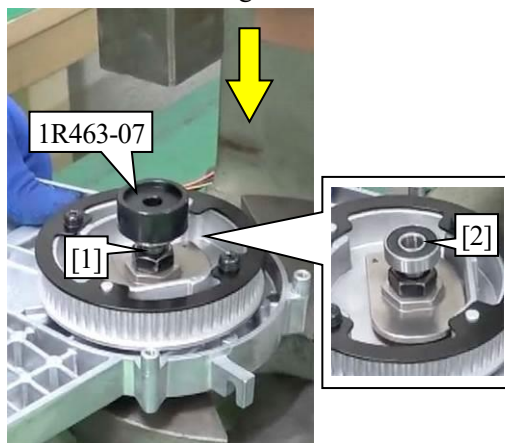
- 17** Align the flats of Shaft 17 [1] with the flats of long hole on Pulley 60 [2], then assemble them.

- 18** Assemble Eccentric disk [3], then temporarily tighten Hex nut M10 [4].

**Note**

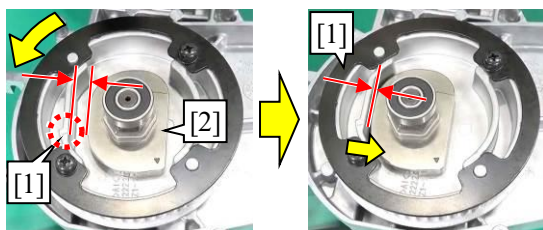
Assemble Eccentric disk [3] with the hex-shaped side facing upward.

Fig. 102



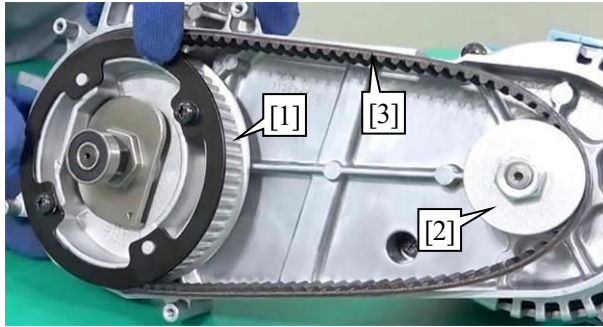
- 19** Assemble Ball bearing 608DDW [2] to Shaft 17 [1], then press-fit Ball bearing 608DDW [2] with 1R463-07.

Fig. 103



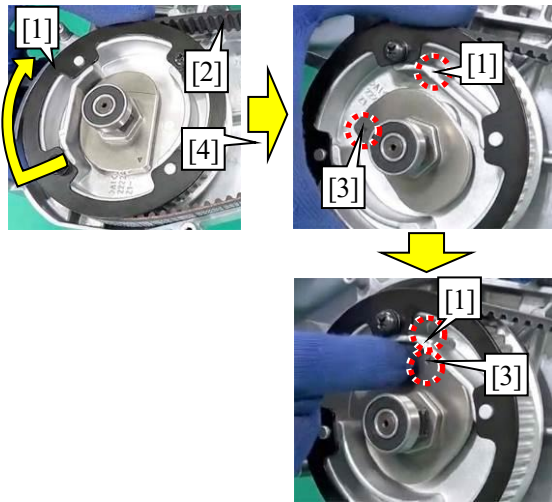
- 20** Turn Pulley 60 [1] until the arrow points outward.
- 21** Move Pulley 60 [1] to the inside so that there is no gap with Eccentric disk [2], then set Synchro belt 15-525 to the maximum loosening position.

Fig. 104



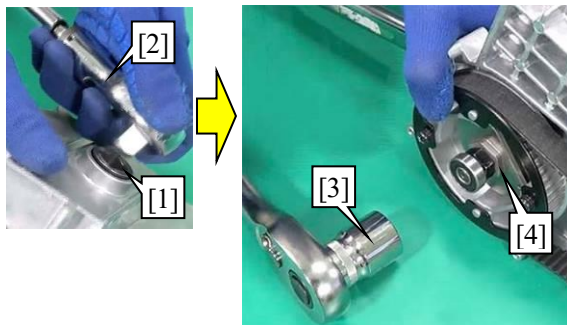
- 22** Assemble Synchro belt 15-525 [3] to Pulley 60 [1] and Pulley 20 [2].

Fig. 105



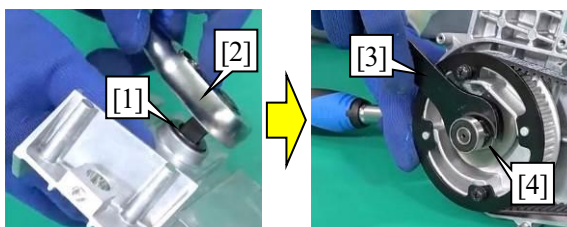
- 23** While pulling Pulley 60 [1] outward, turn Synchro belt 15-525 [2] to the position where it is pulled.
- 24** Turn Eccentric disk [3] until the top of the arrow on Pulley 60 [1] fits the top of the arrow on Eccentric disk [3].

Fig. 106



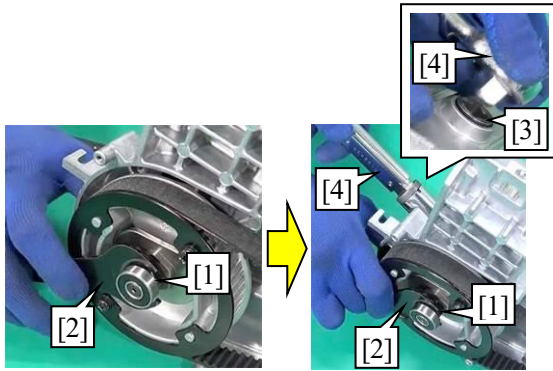
- 25** Set a 1/2-inch torque wrench [2] to Shaft 17 [1] to prevent co-rotation, then tighten Eccentric disk [4] with Hex socket 22 [3] and Ratchet handle.

Fig. 107



- 26** Set a 1/2-inch Ratchet handle [2] to Shaft 17 [1] to prevent rotating, then temporarily tighten Hex nut M10 [4] with Wrench 17 [3].

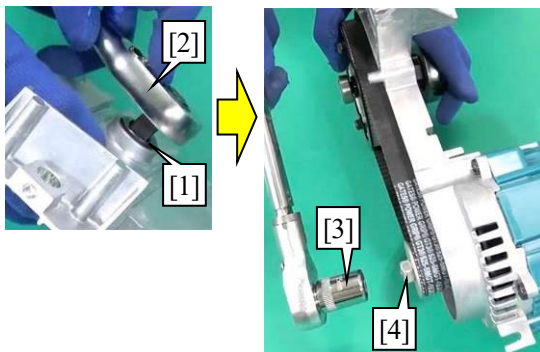
Fig. 108



**27** Set Wrench 17 [2] to Hex nut M10 [1], then place them on a workbench to fix them.

**28** Set a 1/2-inch Torque wrench [4] to Shaft 17 [3], then tighten Hex nut M10 [1] to the specified torque by turning Shaft 17 [3].

Fig. 109

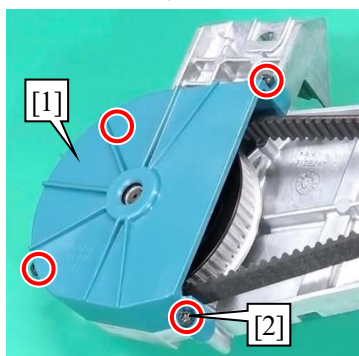


**29** Set a 1/2-inch Ratchet handle [2] to Shaft 17 [1] to prevent rotating, then tighten Hex nut M8-13 [4] to the specified torque with Hex socket 13 [3] and Ratchet handle.

**Note**

While holding Motor section firmly from the top so that it does not come off, tighten Hex nut M8-13 [4].

Fig. 110

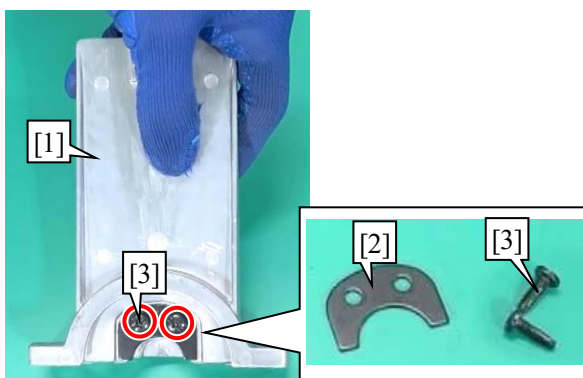


**30** Assemble Bearing cover [1] with P.H.screws M4x16 with WR [2] (4 pcs).

**Tips**

- Because the bearing section is press-fit, hold and assemble Bearing cover from the top.
- In case Bearing cover is hard to assemble by hand, use Arbor press.

Fig. 111



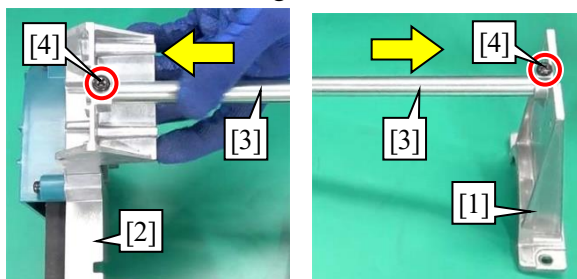
**31** Assemble Bearing retainer [2] to Shaft holder [1] with Tapping screws bind CT4x12 [3] (2 pcs).

**Note**

First tighten the screws with a manual screwdriver to prevent the screw holes from being crushed, then check that the screw threads are aligned, and then tighten with a power tool.



Fig. 112



- 32 Insert Shaft 12 [3] into Shaft holder [1] and Pulley holder [2], then tighten + Pan head screws M5 [4] (2 pcs).

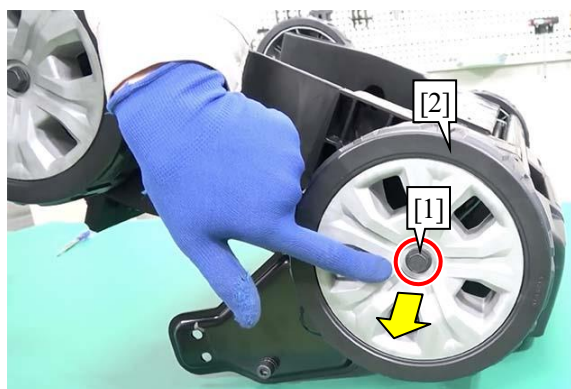
**Note**

Insert Shaft 12 [3] into the bottom so that the orientation of the shape of holes of Shaft holder [1] and Pulley holder [2] are aligned.

## 6-6 Deck section and Wheel section

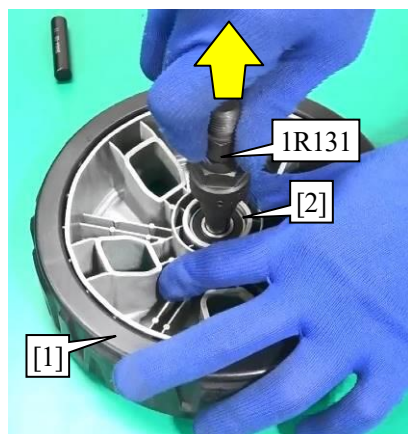
### 6-6-1 Disassembling

Fig. 113



- 1 Turn the machine upside down, then remove Hex flange head bolts M8x12 [1] (4 pcs) from Front shaft and Rear shaft, and then remove Tires 180 [2] (4 pcs).

Fig. 114



- 2 Pull out Ball bearing 6001DDW [2] from Tire 180 [1] with 1R131.

**Tips**

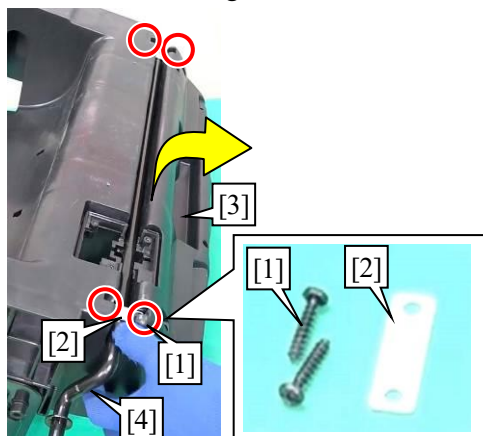
- Replace Ball bearing 6001DDW [2] in Tire 180 [1] if necessary.
- In case it is hard to pull out Ball bearing 6001DDW [2], insert an appropriate Pin jig into the opposite hole of Tire 180 [1], then remove Ball bearing 6001DDW [2] by tapping the hole with a plastic hammer.

Fig. 115



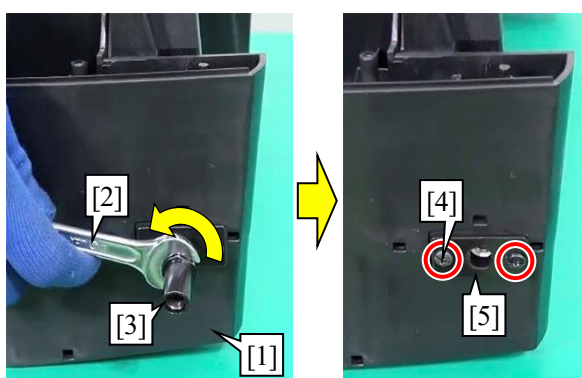
- 3 Remove Tapping screws 4x20 [1] (3 pcs), then remove Under cover [2].

Fig. 116



- 4 Remove Tapping screws 4x20 [1] (4 pcs), then remove Plates [2] (2 pcs).
- 5 Remove Front shaft [4] from Deck [3].

Fig. 117

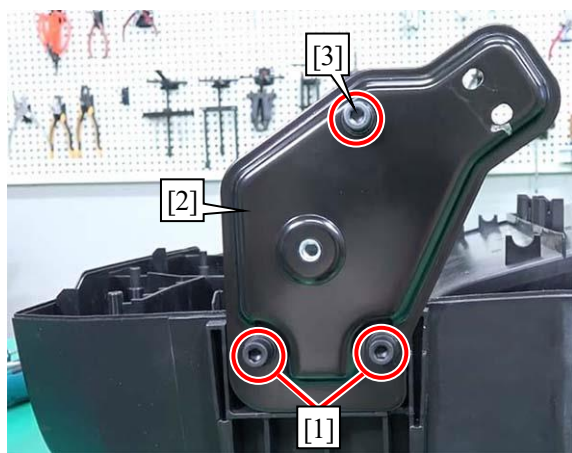


- 6 Turn Deck [1] toward upward, then hook Wrench 13 [2] on the flats of Rear shaft [3], and then remove it by turning it counterclockwise.

Note
Remove Rear shaft [3] before removing Tapping screws 4x20 [4] (2 pcs).

- 7 Remove Tapping screws 4x20 [4] (2 pcs), then remove Rear shaft holder [5].
- 8 Remove the opposite side of Rear shaft [3] and Rear shaft holder [5] in the same way.

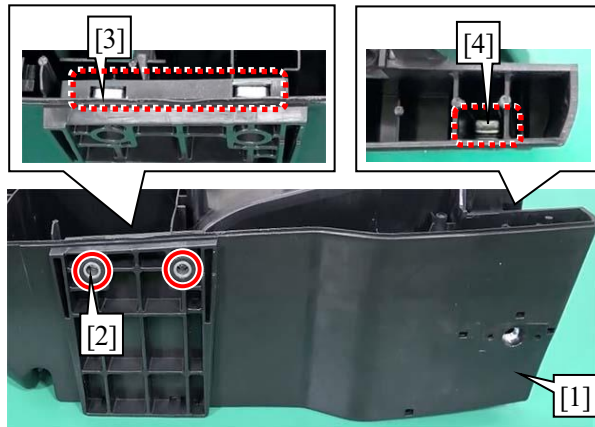
Fig. 118



- 9 Remove H.S.H. bolts M8x25 with WR [1] (2 pcs), then remove Handle bracket L [2].
- 10 Remove Handle bracket R on the opposite side in the same way.

Note
Be careful not to forget to reuse H.S.H. bolt M8x12 with WR [3] when replacing Handle bracket L and Handle bracket R [2].

Fig. 119



**11** Remove Sleeves [2] (2 pcs), Plate nuts M8 [3] (2 pcs) and Plate nut M10 [4] on Front shaft side from Deck [1] with 1R495.

**12** Remove the opposite side in the same way.

**Tips**

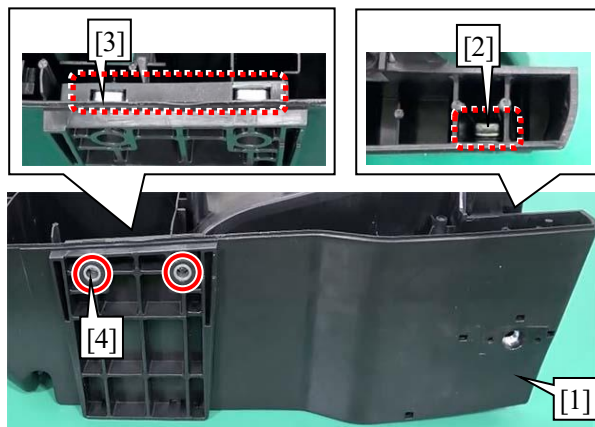
- Plate nut M10 [4] can be removed easily by turning Deck [1] upside down.
- Slightly raise Plate nut M8 [3] with 1R495, then turn Deck [1] upside down, and then remove it by tapping it with a plastic hammer from the lower side of Deck [1].

**Note**

Replace Sleeve [2], Plate nut M8 [3] and Plate nut M10 [4] if necessary.

**6-6-2 Assembling**

Fig. 120



**1** Assemble Plate nut M10 [2] to the center hole of Rear shaft side of Deck [1], Plate nuts M8 [3] (2 pcs) to the hole of the upper surface of Front shaft side, and Sleeves [4] (2 pcs) to the hole of the side.

**2** Assemble the opposite side in the same way.

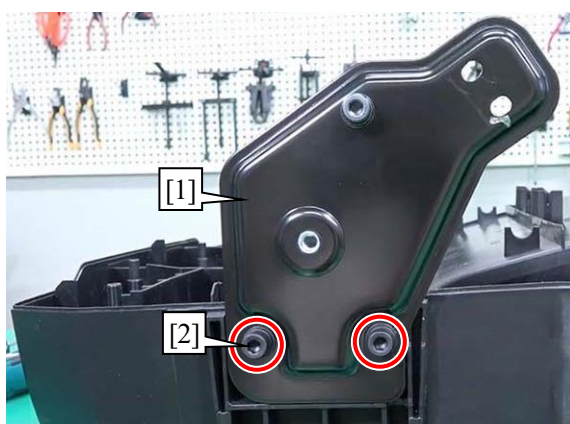
**Tips**

Insert Plate nut M8 [3] into the bottom with 1R495.

**Note**

Be careful not to confuse Plate nut M10 [2] and Plate nut M8 [3].

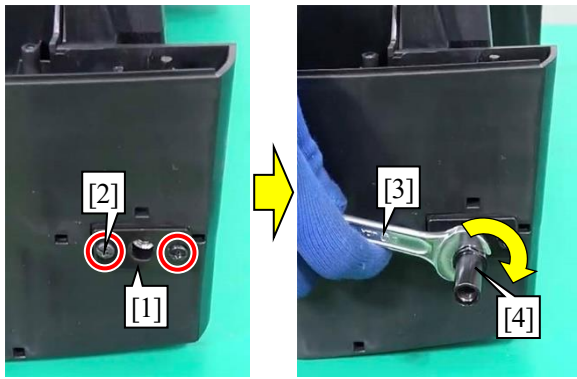
Fig. 121



**3** Assemble Handle bracket L [1] with H.S.H. bolts M8x25 with WR [2] (2 pcs).

**4** Assemble Handle bracket R in the same way for the opposite side.

Fig. 122

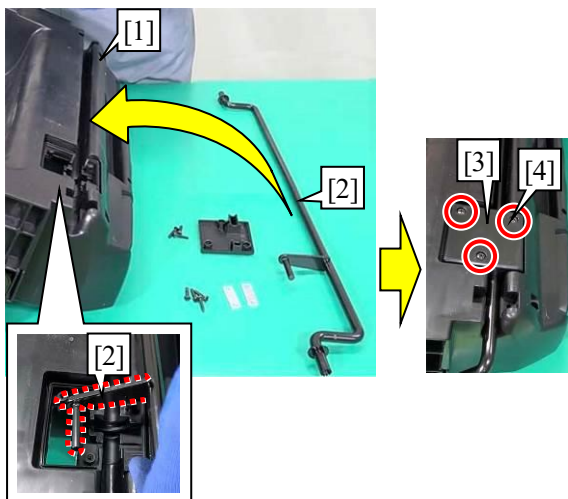


- 5 Assemble Rear shaft holder [1] with Tapping screws 4x20 [2] (2 pcs).
- 6 Hook Wrench 13 [3] on the flats of Rear shaft [4], then tighten it by turning it clockwise.
- 7 Assemble the opposite side of Rear shaft holder [1] and Rear shaft [4] in the same way.

Note

Assemble Rear shaft holder [1] so that its non-protruded side faces outside.

Fig. 123

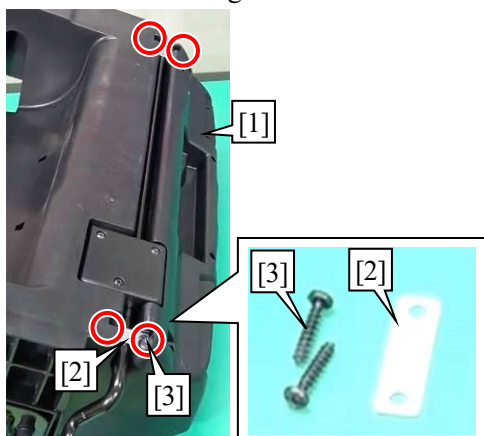


- 8 Assemble Front shaft [2] with Deck [1] facing downward.
- 9 Assemble Under cover [3] with Tapping screws 4x20 [4] (3 pcs).

Note

Assemble Front shaft [2] so that its arm fits into the hole of Deck [1].

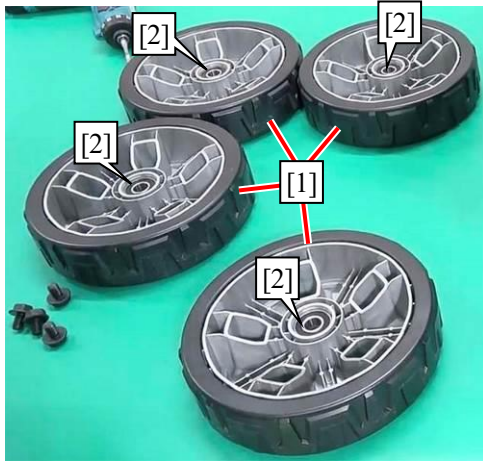
Fig. 124



- 10 Assemble Plates [2] (2 pcs) to Deck [1] with Tapping screws 4x20 [3] (4 pcs).



Fig. 125



- 11 Assemble Ball bearings 6001DDW [2] (4 pcs) to Tires 180 [1] (4 pcs).

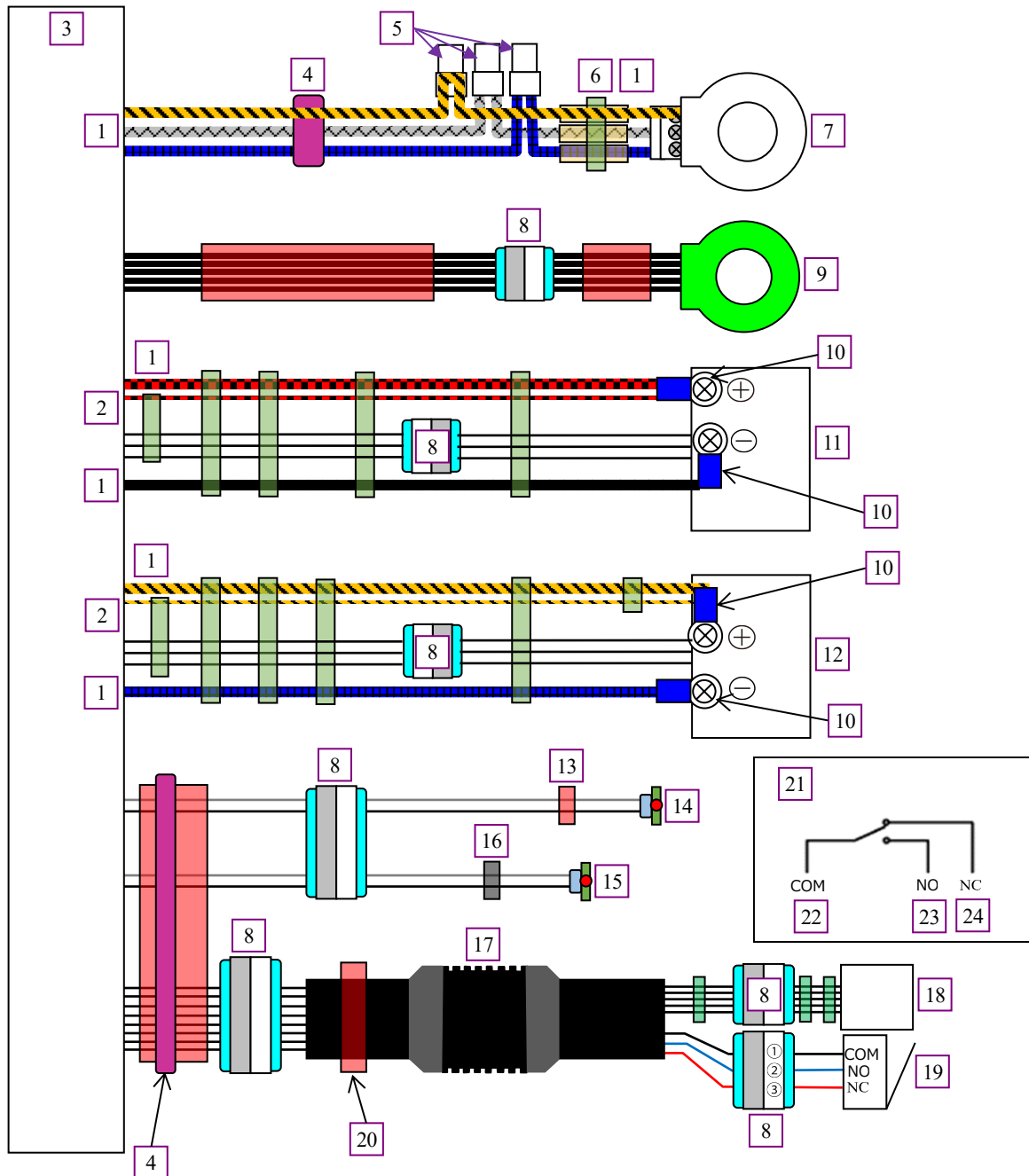
Fig. 126



- 12 Assemble Tires 180 [1] (4 pcs) to Front shaft and Rear shaft with Hex flange head bolts M8x12 [2] (4 pcs).

## 7 CUIT DIAGRAM

Fig. 127

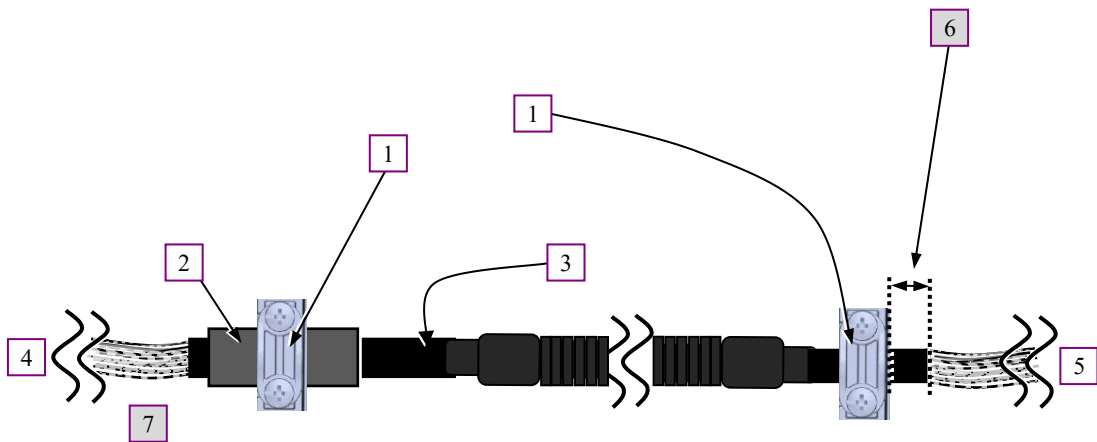


1	AWG14	13	Tape (Red)
2	AWG22	14	LED A (Left side viewed from the rear side of machine)
3	Controller	15	LED B (Right side viewed from the rear side of machine)
4	Line filter (if used)	16	Tape (Black)
5	Closed end splice	17	Power supply cord unit
6	Lead unit	18	Switch circuit
7	Stator	19	Switch unit
8	Connector	20	Tube for assembling of Strain relief
9	Controller B	21	Circuit diagram of Switch
10	Insulated terminal (M3)	22	Black
11	Terminal unit A (Left side viewed from the rear side of machine)	23	Blue
12	Terminal unit B (Right side viewed from the rear side of machine)	24	Red

## 8 WIRING DIAGRAM

### 8-1 Power supply cord unit section

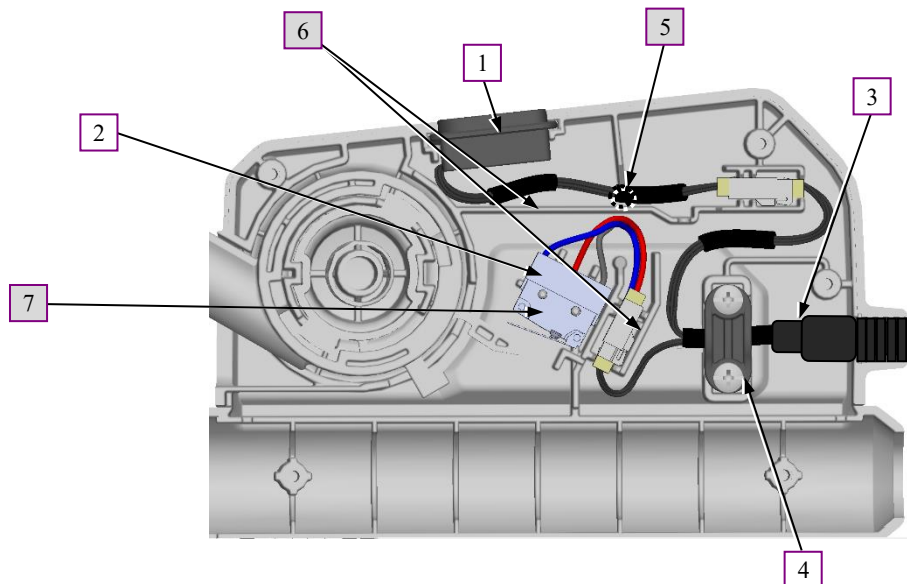
Fig.128



1	Strain relief	4	Deck side
2	Tube	5	Handle side
3	Power supply cord unit		
6	Assemble Strain relief at Handle side so that the sheath of Power supply cord unit protrudes 3-8mm from the end of Strain relief.		
7	Assemble Strain relief at Deck side so that it completely clamps Tube.		

### 8-2 Lever box section

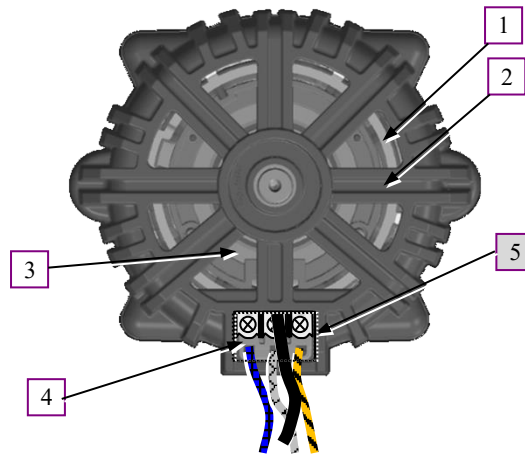
Fig.129



1	Switch circuit	3	Power supply cord unit
2	Switch unit	4	Strain relief
5	Fix Switch circuit lead wires in this groove.		
6	Be careful not to put Lead wires on these ribs.		
7	Assemble Switch unit so that its black lead wire comes to Strain relief side.		

### 8-3 Motor housing section

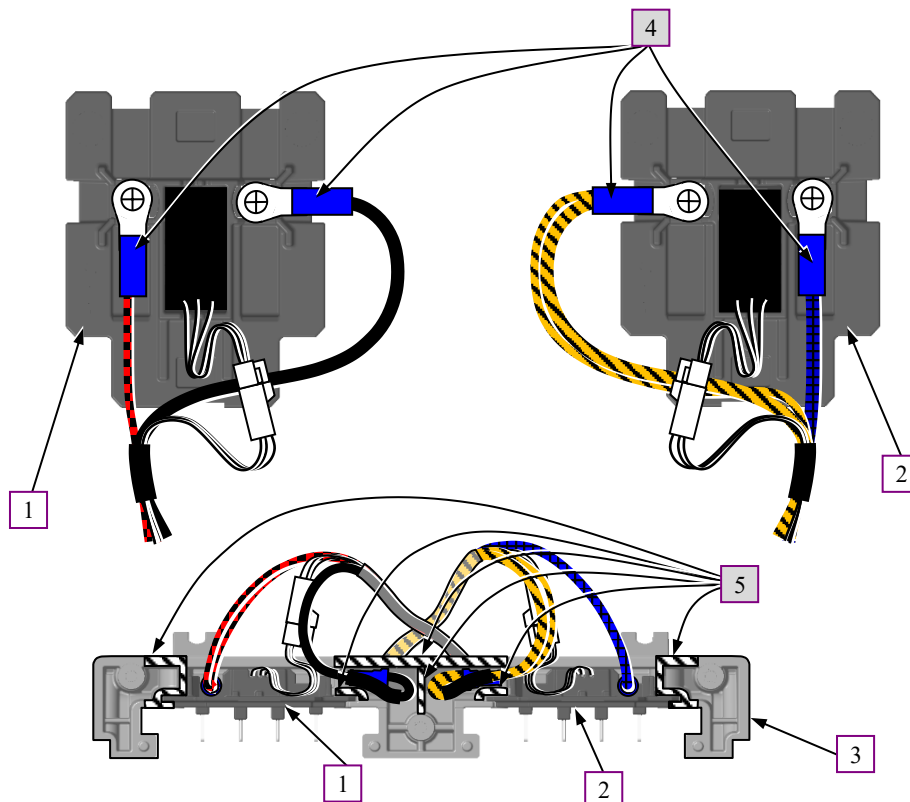
Fig.130



1	Stator	3	Controller B
2	Motor housing	4	Lead unit
5	Pass Lead unit lead wires for Stator and Controller B lead wires through this opening of Motor housing.		

### 8-4 Terminal unit section

Fig.131

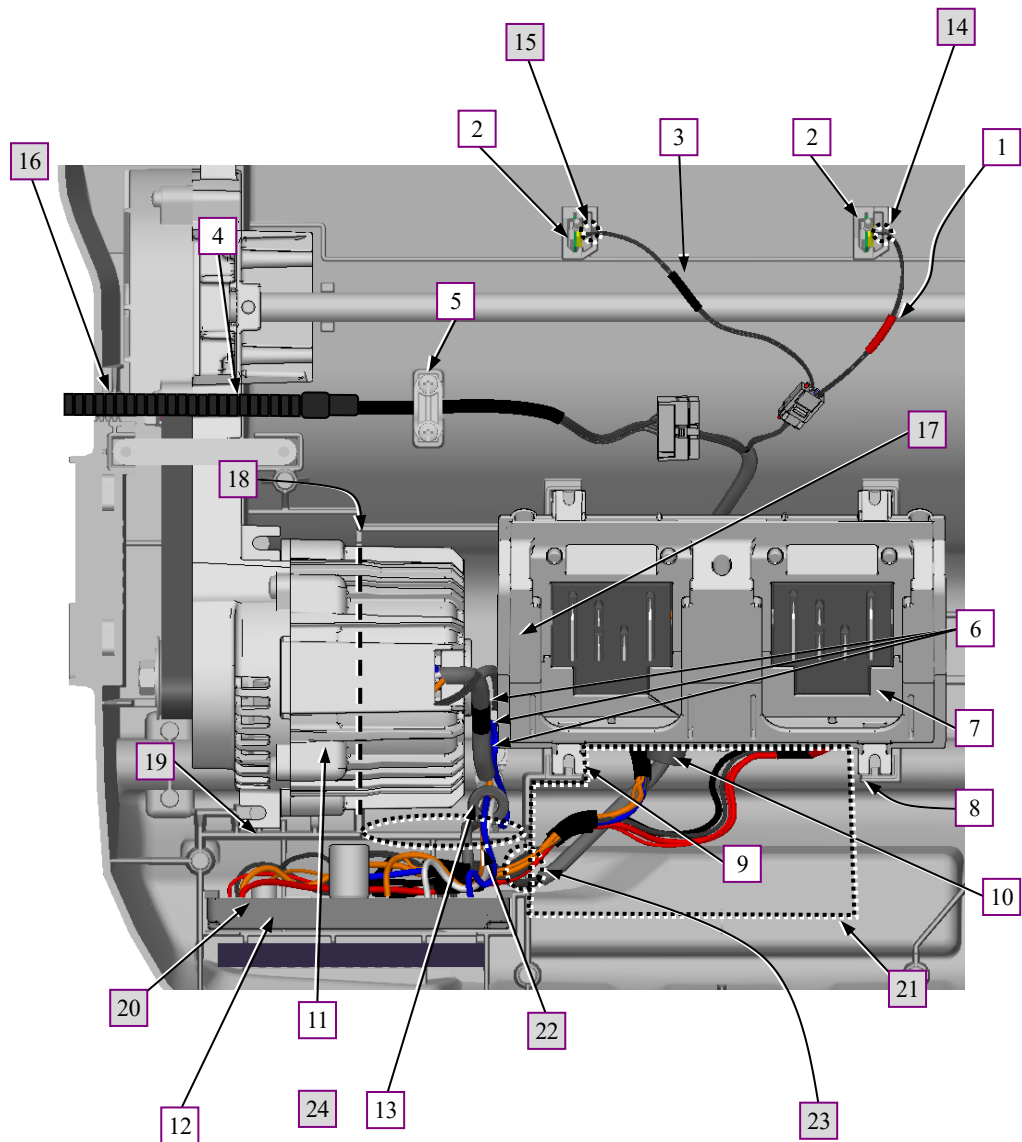


1	Terminal unit A	3	Terminal housing R
2	Terminal unit B		
4	Connect Insulated terminals to Terminal units so that their lead wires come out as shown.		
5	Be careful not put Lead wires for Terminal unit A/ Terminal unit B on these ribs.		



## 8-5 Deck section

Fig.132



1	Tape (Red)	8	Rib B
2	LED circuit	9	Rib A
3	Tape (Black)	10	Line filter A (if used)
4	Power supply cord unit	11	Motor housing
5	Strain relief	12	Controller
6	Closed end splice	13	Line filter B (if used)
7	Terminal housing		
14	Fix LED circuit lead wire with Tape (Red) in this groove.		
15	Fix LED circuit lead wire with Tape (Black) in this groove.		
16	Be careful not to slacken Power supply cord unit between this groove and Strain relief.		
17	Be careful not to put Lead wires and Terminals on Terminal housing.		
18	Be careful not to put lead wires and Terminals on Motor housing on the left side of this dotted line.		
19	Be careful not to put Lead wires on this rib.		
20	Assemble Controller so that its thin lead wires come to the inner wall side of Deck.		
21	Place Line filter A in this space or the lower side of Terminal housing.		
22	Fix Controller lead wires for Stator in this groove.		
23	Route the following lead wires in this groove/ between Rib A and Rib B: <ul style="list-style-type: none"> <li>• Controller lead wires for LED circuit</li> <li>• Controller lead wires for Power supply cord unit</li> <li>• Controller lead wires for Terminal unit</li> </ul>		
24	Pass the thick Controller lead wires (Orange, White, Blue) for Stator through Line filter B.		

## 9 TROUBLESHOOTING

Whenever you find any trouble in your machine, first, see this list to check the machine for solution.

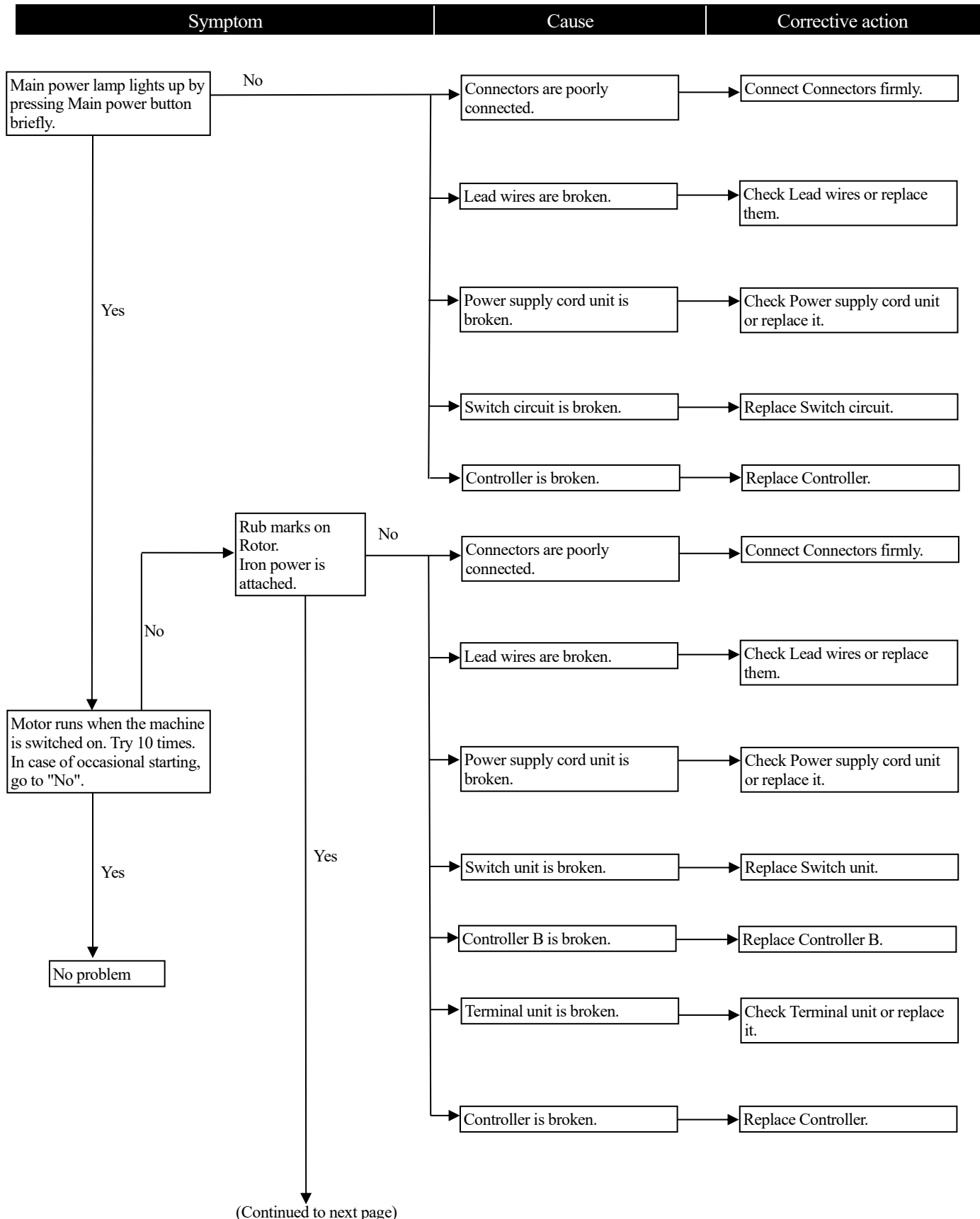
### 9-1 Note for Repairing

The content may vary depending on the model.

- 1 Use a full charged batteries.
- 2 When Housing is disassembled, check the conditions of the electrical parts (Connectors, Lead wires, Switches, etc.), Rotor, Stator, Gear section, etc.
- 3 Be sure to test the machine 10 times to correctly diagnose functions such as Switch etc.

## 9-2 Flowchart for Troubleshooting

Check the items in the following flowchart in order from the top to bottom. Description of the item is referred to CIRCUIT DIAGRAM. After corrective action, return to the start of Troubleshooting and re-check again.



(Continued from previous page)

