

INSTRUCTION MANUAL

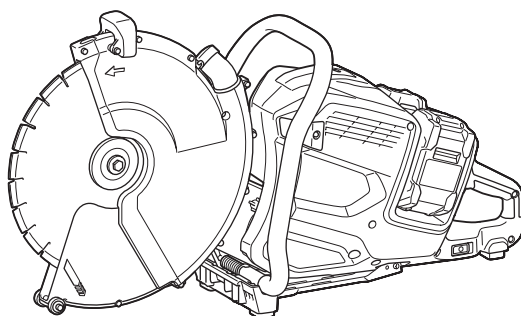

Cordless Power Cutter

CE002G



Read before use.

SPECIFICATIONS

Model:	CE002G
Wheel diameter	350 - 355 mm
Max. wheel thickness	4.0 mm
Max. cutting depth	127 mm
Rated speed	4,200 min ⁻¹
Rated voltage	D.C. 72 V - 80 V max
Recommended air volume of the vacuum cleaner	Equal to or more than 1.8 m ³ /min
Overall length	825 mm
Net weight	13.1 - 15.1 kg

- Due to our continuing program of research and development, the specifications herein are subject to change without notice.
- Specifications may differ from country to country.
- The weight may differ depending on the attachment(s), including the battery cartridge. The lightest and heaviest combinations, according to EPTA-Procedure 01/2014, are shown in the table.

Applicable battery cartridge and charger





Battery cartridge	BL4040 / BL4050F* / BL4080F* *: Recommended battery
Charger	DC40RA / DC40RB / DC40RC

- Some of the battery cartridges and chargers listed above may not be available depending on your region of residence.

⚠ WARNING: Only use the battery cartridges and chargers listed above. Use of any other battery cartridges and chargers may cause injury and/or fire.

Symbols

The followings show the symbols which may be used for the equipment. Be sure that you understand their meaning before use.

	Read instruction manual.
	Wear safety glasses.
	Do not use abrasive cut-off wheel. Only diamond wheel is applicable.
	Do not cut metal.
	Do not feed water.



Only for EU countries

Due to the presence of hazardous components in the equipment, waste electrical and electronic equipment, accumulators and batteries may have a negative impact on the environment and human health.

Do not dispose of electrical and electronic appliances or batteries with household waste!

In accordance with the European Directive on waste electrical and electronic equipment and on accumulators and batteries and waste accumulators and batteries, as well as their adaptation to national law, waste electrical equipment, batteries and accumulators should be stored separately and delivered to a separate collection point for municipal waste, operating in accordance with the regulations on environmental protection.

This is indicated by the symbol of the crossed-out wheeled bin placed on the equipment.

Intended use

The tool is intended for cutting in masonry materials with a diamond wheel.

Noise

The typical A-weighted noise level determined according to EN60745-2-22:

Sound pressure level (L_{pA}) : 106 dB(A)

Sound power level (L_{WA}) : 117 dB (A)

Uncertainty (K) : 3 dB(A)

NOTE: The declared noise emission value(s) has been measured in accordance with a standard test method and may be used for comparing one tool with another.

NOTE: The declared noise emission value(s) may also be used in a preliminary assessment of exposure.

⚠ WARNING: Wear ear protection.

⚠ WARNING: The noise emission during actual use of the power tool can differ from the declared value(s) depending on the ways in which the tool is used especially what kind of workpiece is processed.

⚠ WARNING: Be sure to identify safety measures to protect the operator that are based on an estimation of exposure in the actual conditions of use (taking account of all parts of the operating cycle such as the times when the tool is switched off and when it is running idle in addition to the trigger time).

Vibration

Work mode: concrete cutting

Left hand		Right hand		Applicable standard
$a_{h,W}$ (m/s ²)	Uncertainty K (m/s ²)	$a_{h,W}$ (m/s ²)	Uncertainty K (m/s ²)	
≤ 2.5	1.5	≤ 2.5	1.5	EN60745-2-22

NOTE: The declared vibration total value(s) has been measured in accordance with a standard test method and may be used for comparing one tool with another.

NOTE: The declared vibration total value(s) may also be used in a preliminary assessment of exposure.

⚠ WARNING: The vibration emission during actual use of the power tool can differ from the declared value(s) depending on the ways in which the tool is used especially what kind of workpiece is processed.

⚠ WARNING: Be sure to identify safety measures to protect the operator that are based on an estimation of exposure in the actual conditions of use (taking account of all parts of the operating cycle such as the times when the tool is switched off and when it is running idle in addition to the trigger time).

Declarations of Conformity

For European countries only

The Declarations of conformity are included in Annex A to this instruction manual.

SAFETY WARNINGS

General power tool safety warnings

⚠ WARNING Read all safety warnings, instructions, illustrations and specifications provided with this power tool. Failure to follow all instructions listed below may result in electric shock, fire and/or serious injury.

Save all warnings and instructions for future reference.

The term "power tool" in the warnings refers to your mains-operated (corded) power tool or battery-operated (cordless) power tool.

Work area safety

1. **Keep work area clean and well lit.** Cluttered or dark areas invite accidents.
2. **Do not operate power tools in explosive atmospheres, such as in the presence of flammable liquids, gases or dust.** Power tools create sparks which may ignite the dust or fumes.
3. **Keep children and bystanders away while operating a power tool.** Distractions can cause you to lose control.

Electrical safety

1. **Power tool plugs must match the outlet. Never modify the plug in any way. Do not use any adapter plugs with earthed (grounded) power tools.** Unmodified plugs and matching outlets will reduce risk of electric shock.
2. **Avoid body contact with earthed or grounded surfaces, such as pipes, radiators, ranges and refrigerators.** There is an increased risk of electric shock if your body is earthed or grounded.
3. **Do not expose power tools to rain or wet conditions.** Water entering a power tool will increase the risk of electric shock.

4. **Do not abuse the cord. Never use the cord for carrying, pulling or unplugging the power tool. Keep cord away from heat, oil, sharp edges or moving parts.** Damaged or entangled cords increase the risk of electric shock.
5. **When operating a power tool outdoors, use an extension cord suitable for outdoor use.** Use of a cord suitable for outdoor use reduces the risk of electric shock.
6. **If operating a power tool in a damp location is unavoidable, use a residual current device (RCD) protected supply.** Use of an RCD reduces the risk of electric shock.
7. **Power tools can produce electromagnetic fields (EMF) that are not harmful to the user.** However, users of pacemakers and other similar medical devices should contact the maker of their device and/or doctor for advice before operating this power tool.

Personal safety

1. **Stay alert, watch what you are doing and use common sense when operating a power tool. Do not use a power tool while you are tired or under the influence of drugs, alcohol or medication.** A moment of inattention while operating power tools may result in serious personal injury.
2. **Use personal protective equipment. Always wear eye protection.** Protective equipment such as a dust mask, non-skid safety shoes, hard hat or hearing protection used for appropriate conditions will reduce personal injuries.
3. **Prevent unintentional starting. Ensure the switch is in the off-position before connecting to power source and/or battery pack, picking up or carrying the tool.** Carrying power tools with your finger on the switch or energising power tools that have the switch on invites accidents.
4. **Remove any adjusting key or wrench before turning the power tool on.** A wrench or a key left attached to a rotating part of the power tool may result in personal injury.
5. **Do not overreach. Keep proper footing and balance at all times.** This enables better control of the power tool in unexpected situations.
6. **Dress properly. Do not wear loose clothing or jewellery. Keep your hair and clothing away from moving parts.** Loose clothes, jewellery or long hair can be caught in moving parts.
7. **If devices are provided for the connection of dust extraction and collection facilities, ensure these are connected and properly used.** Use of dust collection can reduce dust-related hazards.
8. **Do not let familiarity gained from frequent use of tools allow you to become complacent and ignore tool safety principles.** A careless action can cause severe injury within a fraction of a second.
9. **Always wear protective goggles to protect your eyes from injury when using power tools. The goggles must comply with ANSI Z87.1 in the USA, EN 166 in Europe, or AS/NZS 1336 in Australia/New Zealand. In Australia/New Zealand, it is legally required to wear a face shield to protect your face, too.**

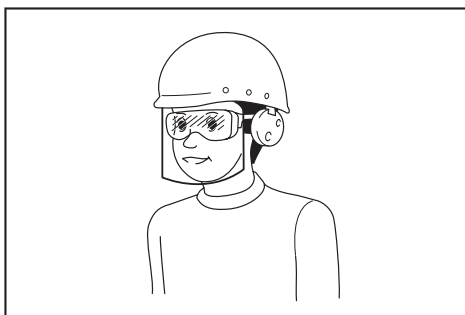

It is an employer's responsibility to enforce the use of appropriate safety protective equipments by the tool operators and by other persons in the immediate working area.

Power tool use and care

1. **Do not force the power tool. Use the correct power tool for your application.** The correct power tool will do the job better and safer at the rate for which it was designed.
2. **Do not use the power tool if the switch does not turn it on and off.** Any power tool that cannot be controlled with the switch is dangerous and must be repaired.
3. **Disconnect the plug from the power source and/or remove the battery pack, if detachable, from the power tool before making any adjustments, changing accessories, or storing power tools.** Such preventive safety measures reduce the risk of starting the power tool accidentally.
4. **Store idle power tools out of the reach of children and do not allow persons unfamiliar with the power tool or these instructions to operate the power tool.** Power tools are dangerous in the hands of untrained users.
5. **Maintain power tools and accessories. Check for misalignment or binding of moving parts, breakage of parts and any other condition that may affect the power tool's operation. If damaged, have the power tool repaired before use.** Many accidents are caused by poorly maintained power tools.
6. **Keep cutting tools sharp and clean.** Properly maintained cutting tools with sharp cutting edges are less likely to bind and are easier to control.
7. **Use the power tool, accessories and tool bits etc. in accordance with these instructions, taking into account the working conditions and the work to be performed.** Use of the power tool for operations different from those intended could result in a hazardous situation.
8. **Keep handles and grasping surfaces dry, clean and free from oil and grease.** Slippery handles and grasping surfaces do not allow for safe handling and control of the tool in unexpected situations.
9. **When using the tool, do not wear cloth work gloves which may be entangled.** The entanglement of cloth work gloves in the moving parts may result in personal injury.

Battery tool use and care

1. **Recharge only with the charger specified by the manufacturer.** A charger that is suitable for one type of battery pack may create a risk of fire when used with another battery pack.
2. **Use power tools only with specifically designed battery packs.** Use of any other battery packs may create a risk of injury and fire.
3. **When battery pack is not in use, keep it away from other metal objects, like paper clips, coins, keys, nails, screws or other small metal objects, that can make a connection from one terminal to another.** Shorting the battery terminals together may cause burns or a fire.
4. **Under abusive conditions, liquid may be ejected from the battery; avoid contact. If contact accidentally occurs, flush with water. If liquid contacts eyes, additionally seek medical help.** Liquid ejected from the battery may cause irritation or burns.
5. **Do not use a battery pack or tool that is damaged or modified.** Damaged or modified batteries may exhibit unpredictable behaviour resulting in fire, explosion or risk of injury.
6. **Do not expose a battery pack or tool to fire or excessive temperature.** Exposure to fire or temperature above 130 °C may cause explosion.
7. **Follow all charging instructions and do not charge the battery pack or tool outside the temperature range specified in the instructions.** Charging improperly or at temperatures outside the specified range may damage the battery and increase the risk of fire.

Service

1. **Have your power tool serviced by a qualified repair person using only identical replacement parts.** This will ensure that the safety of the power tool is maintained.
2. **Never service damaged battery packs.** Service of battery packs should only be performed by the manufacturer or authorized service providers.
3. **Follow instruction for lubricating and changing accessories.**

Cordless power cutter safety warnings

Cut-off machine safety warnings

1. **The guard provided with the tool must be securely attached to the power tool and positioned for maximum safety, so the least amount of wheel is exposed towards the operator. Position yourself and bystanders away from the plane of the rotating wheel.** The guard helps to protect operator from broken wheel fragments and accidental contact with wheel.
2. **Use only diamond cut-off wheels for your power tool.** Just because an accessory can be attached to your power tool, it does not assure safe operation.
3. **The rated speed of the accessory must be at least equal to the maximum speed marked on the power tool.** Accessories running faster than their rated speed can break and fly apart.
4. **Wheels must be used only for recommended applications. For example: do not grind with the side of cut-off wheel.** Cut-off wheels are intended for peripheral grinding, side forces applied to these wheels may cause them to shatter.
5. **Always use undamaged wheel flanges that are of correct diameter for your selected wheel.** Proper wheel flanges support the wheel thus reducing the possibility of wheel breakage.
6. **The outside diameter and the thickness of your accessory must be within the capacity rating of your power tool.** Incorrectly sized accessories cannot be adequately guarded or controlled.
7. **The arbour size of wheels and flanges must properly fit the spindle of the power tool.** Wheels and flanges with arbour holes that do not match the mounting hardware of the power tool will run out of balance, vibrate excessively and may cause loss of control.
8. **Do not use damaged wheels. Before each use, inspect the wheels for chips and cracks. If power tool or wheel is dropped, inspect for damage or install an undamaged wheel. After inspecting and installing the wheel, position yourself and bystanders away from the plane of the rotating wheel and run the power tool at maximum no load speed for one minute.** Damaged wheels will normally break apart during this test time.
9. **Wear personal protective equipment. Depending on application, use face shield, safety goggles or safety glasses. As appropriate, wear dust mask, hearing protectors, gloves and shop apron capable of stopping small abrasive or workpiece fragments.** The eye protection must be capable of stopping flying debris generated by various operations. The dust mask or respirator must be capable of filtering particles generated by your operation. Prolonged exposure to high intensity noise may cause hearing loss.
10. **Keep bystanders a safe distance away from work area. Anyone entering the work area must wear personal protective equipment.** Fragments of workpiece or of a broken wheel may fly away and cause injury beyond immediate area of operation.
11. **Hold the power tool by insulated gripping surfaces only, when performing an operation where the cutting accessory may contact hidden wiring.** Cutting accessory contacting a "live" wire may make exposed metal parts of the power tool "live" and could give the operator an electric shock.
12. **Never lay the power tool down until the accessory has come to a complete stop.** The spinning wheel may grab the surface and pull the power tool out of your control.
13. **Do not run the power tool while carrying it at your side.** Accidental contact with the spinning accessory could snag your clothing, pulling the accessory into your body.
14. **Regularly clean the power tool's air vents.** The motor's fan will draw the dust inside the housing and excessive accumulation of powdered metal may cause electrical hazards.

15. **Do not operate the power tool near flammable materials.** Sparks could ignite these materials.
16. **Do not use accessories that require liquid coolants.** Using water or other liquid coolants may result in electrocution or shock.

Kickback and related warnings

Kickback is a sudden reaction to a pinched or snagged rotating wheel. Pinching or snagging causes rapid stalling of the rotating wheel which in turn causes the uncontrolled power tool to be forced in the direction opposite of the wheel's rotation at the point of the binding.

For example, if a wheel is snagged or pinched by the workpiece, the edge of the wheel that is entering into the pinch point can dig into the surface of the material causing the wheel to climb out or kick out. The wheel may either jump toward or away from the operator, depending on direction of the wheel's movement at the point of pinching. Wheels may also break under these conditions.

Kickback is the result of power tool misuse and/or incorrect operating procedures or conditions and can be avoided by taking proper precautions as given below.

1. **Maintain a firm grip on the power tool and position your body and arm to allow you to resist kickback forces. Always use auxiliary handle, if provided, for maximum control over kickback or torque reaction during start-up.** The operator can control torque reactions or kickback forces, if proper precautions are taken.
2. **Never place your hand near the rotating accessory.** Accessory may kickback over your hand.
3. **Do not position your body in line with the rotating wheel.** Kickback will propel the tool in direction opposite to the wheel's movement at the point of snagging.
4. **Use special care when working corners, sharp edges etc. Avoid bouncing and snagging the accessory.** Corners, sharp edges or bouncing have a tendency to snag the rotating accessory and cause loss of control or kickback.
5. **Do not attach a saw chain, woodcarving blade, segmented diamond wheel with a peripheral gap greater than 10 mm (3/8") or toothed saw blade.** Such blades create frequent kickback and loss of control.
6. **Do not "jam" the wheel or apply excessive pressure. Do not attempt to make an excessive depth of cut.** Overstressing the wheel increases the loading and susceptibility to twisting or binding of the wheel in the cut and the possibility of kickback or wheel breakage.
7. **When wheel is binding or when interrupting a cut for any reason, switch off the power tool and hold the power tool motionless until the wheel comes to a complete stop. Never attempt to remove the wheel from the cut while the wheel is in motion otherwise kickback may occur.** Investigate and take corrective action to eliminate the cause of wheel binding.
8. **Do not restart the cutting operation in the workpiece. Let the wheel reach full speed and carefully re-enter the cut.** The wheel may bind, walk up or kickback if the power tool is restarted in the workpiece.
9. **Support panels or any oversized workpiece to minimize the risk of wheel pinching and kickback.** Large workpieces tend to sag under their own weight. Supports must be placed under the workpiece near the line of cut and near the edge of the workpiece on both sides of the wheel.
10. **Use extra caution when making a "pocket cut" into existing walls or other blind areas.** The protruding wheel may cut gas or water pipes, electrical wiring or objects that can cause kickback.

Additional Safety Warnings:

1. **Do not use abrasive cut-off wheel.** Otherwise fire and/or excessive heating may cause burn injury.
2. **Do not cut metal object.** Otherwise fire and/or excessive heating may cause burn injury.
3. **Before using a segmented diamond wheel, make sure that the diamond wheel has the peripheral gap between segments of 10 mm (3/8") or less, only with a negative rake angle.**
4. **Never attempt to cut with the tool held upside down in a vise. This can lead to serious accidents, because it is extremely dangerous.**
5. **Some material contains chemicals which may be toxic. Take caution to prevent dust inhalation and skin contact. Follow material supplier safety data.**
6. **Store wheels as per manufacturer recommendations. Improper storage may damage the wheels.**
7. **Always use the wheel suitable for your work and the material to be cut.**
8. **Examine the material to be cut before cutting.** If the material contains explosive or flammable substances, it may cause an explosion or fire.
9. **Do not switch on the tool if a foreign object is jammed between the wheel cover and the wheel.** In this case, uninstall the battery cartridge and remove the foreign object.
10. **Use clamps or similar to support the workpiece whenever possible.**
11. **Always wear hearing protection during operation.**
12. **Do not cut wood materials with this tool.**
13. **The outside diameter and the thickness of the wheel must be within the capacity rating of your power tool.** Incorrectly sized wheels cannot be adequately guarded or controlled.
14. **When operating the power tool, maintain a firm grip with both hands on the power tool and position your body and arm to allow you to resist kickback forces.**
15. **Keep your hands or face away from the rotating wheel.**
16. **Adjust the wheel cover to a position suitable for your work.**
17. **Do not wet the tool with water, rain, mud, and puddle.**
18. **Do not leave the tool unattended outdoors.**
19. **When storing the tool, avoid direct sunlight and rain, and store it in a place where it does not get hot or humid.**
20. **Clean the filter of vacuum cleaner regularly.**

SAVE THESE INSTRUCTIONS.

⚠WARNING: DO NOT let comfort or familiarity with product (gained from repeated use) replace strict adherence to safety rules for the subject product. MISUSE or failure to follow the safety rules stated in this instruction manual may cause serious personal injury.

Important safety instructions for battery cartridge

1. Before using battery cartridge, read all instructions and cautionary markings on (1) battery charger, (2) battery, and (3) product using battery.
2. Do not disassemble or tamper with the battery cartridge. It may result in a fire, excessive heat, or explosion.
3. If operating time has become excessively shorter, stop operating immediately. It may result in a risk of overheating, possible burns and even an explosion.
4. If electrolyte gets into your eyes, rinse them out with clear water and seek medical attention right away. It may result in loss of your eyesight.
5. Do not short the battery cartridge:
 - (1) Do not touch the terminals with any conductive material.
 - (2) Avoid storing battery cartridge in a container with other metal objects such as nails, coins, etc.
 - (3) Do not expose battery cartridge to water or rain.
6. Do not store and use the tool and battery cartridge in locations where the temperature may reach or exceed 50 °C (122 °F).
7. Do not incinerate the battery cartridge even if it is severely damaged or is completely worn out. The battery cartridge can explode in a fire.
8. Do not nail, cut, crush, throw, drop the battery cartridge, or hit against a hard object to the battery cartridge. Such conduct may result in a fire, excessive heat, or explosion.
9. Do not use a damaged battery.
10. The contained lithium-ion batteries are subject to the Dangerous Goods Legislation requirements.

For commercial transports e.g. by third parties, forwarding agents, special requirement on packaging and labeling must be observed.

For preparation of the item being shipped, consulting an expert for hazardous material is required. Please also observe possibly more detailed national regulations.

Tape or mask off open contacts and pack up the battery in such a manner that it cannot move around in the packaging.

11. When disposing the battery cartridge, remove it from the tool and dispose of it in a safe place. Follow your local regulations relating to disposal of battery.
12. Use the batteries only with the products specified by Makita. Installing the batteries to non-compliant products may result in a fire, excessive heat, explosion, or leak of electrolyte.
13. If the tool is not used for a long period of time, the battery must be removed from the tool.
14. During and after use, the battery cartridge may take on heat which can cause burns or low temperature burns. Pay attention to the handling of hot battery cartridges.
15. Do not touch the terminal of the tool immediately after use as it may get hot enough to cause burns.
16. Do not allow chips, dust, or soil stuck into the terminals, holes, and grooves of the battery cartridge. It may cause heating, catching fire, burst and malfunction of the tool or battery cartridge, resulting in burns or personal injury.
17. Unless the tool supports the use near high-voltage electrical power lines, do not use the battery cartridge near high-voltage electrical power lines. It may result in a malfunction or breakdown of the tool or battery cartridge.
18. Keep the battery away from children.

SAVE THESE INSTRUCTIONS.

⚠CAUTION: Only use genuine Makita batteries. Use of non-genuine Makita batteries, or batteries that have been altered, may result in the battery bursting causing fires, personal injury and damage. It will also void the Makita warranty for the Makita tool and charger.

Tips for maintaining maximum battery life

1. Charge the battery cartridge before completely discharged. Always stop tool operation and charge the battery cartridge when you notice less tool power.
2. Never recharge a fully charged battery cartridge. Overcharging shortens the battery service life.
3. Charge the battery cartridge with room temperature at 10 °C - 40 °C (50 °F - 104 °F). Let a hot battery cartridge cool down before charging it.
4. When not using the battery cartridge, remove it from the tool or the charger.
5. Charge the battery cartridge if you do not use it for a long period (more than six months).

Important safety instructions for wireless unit

1. Do not disassemble or tamper with the wireless unit.
2. Keep the wireless unit away from young children. If accidentally swallowed, seek medical attention immediately.
3. Use the wireless unit only with Makita tools.
4. Do not expose the wireless unit to rain or wet conditions.
5. Do not use the wireless unit in places where the temperature exceeds 50 °C (122 °F).
6. Do not operate the wireless unit in places where medical instruments, such as heart pace makers are nearby.
7. Do not operate the wireless unit in places where automated devices are nearby. If operated, automated devices may develop malfunction or error.
8. Do not operate the wireless unit in places under high temperature or places where static electricity or electrical noise could be generated.
9. The wireless unit can produce electromagnetic fields (EMF) but they are not harmful to the user.
10. The wireless unit is an accurate instrument. Be careful not to drop or strike the wireless unit.
11. Avoid touching the terminal of the wireless unit with bare hands or metallic materials.
12. Always remove the battery on the product when installing the wireless unit into it.
13. When opening the lid of the slot, avoid the place where dust and water may come into the slot. Always keep the inlet of the slot clean.
14. Always insert the wireless unit in the correct direction.
15. Do not press the wireless activation button on the wireless unit too hard and/or press the button with an object with a sharp edge.
16. Always close the lid of the slot when operating.
17. Do not remove the wireless unit from the slot while the power is being supplied to the tool. Doing so may cause a malfunction of the wireless unit.
18. Do not remove the sticker on the wireless unit.
19. Do not put any sticker on the wireless unit.
20. Do not leave the wireless unit in a place where static electricity or electrical noise could be generated.
21. Do not leave the wireless unit in a place subject to high heat, such as a car sitting in the sun.
22. Do not leave the wireless unit in a dusty or powdery place or in a place corrosive gas could be generated.
23. Sudden change of the temperature may bedew the wireless unit. Do not use the wireless unit until the dew is completely dried.
24. When cleaning the wireless unit, gently wipe with a dry soft cloth. Do not use benzine, thinner, conductive grease or the like.
25. When storing the wireless unit, keep it in the supplied case or a static-free container.
26. Do not insert any devices other than Makita wireless unit into the slot on the tool.
27. Do not use the tool with the lid of the slot damaged. Water, dust, and dirt come into the slot may cause malfunction.
28. Do not pull and/or twist the lid of the slot more than necessary. Restore the lid if it comes off from the tool.
29. Replace the lid of the slot if it is lost or damaged.

SAVE THESE INSTRUCTIONS.

PARTS DESCRIPTION

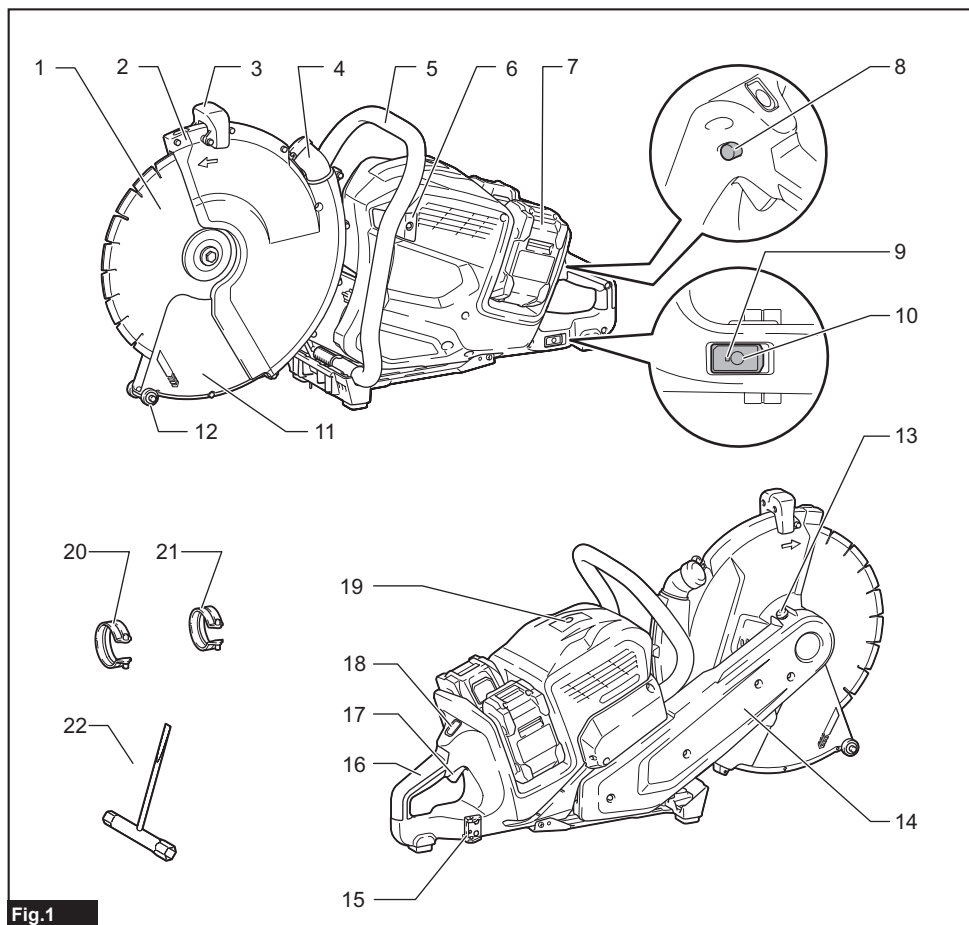

Fig.1

1	Diamond wheel	2	Wheel cover	3	Wheel cover grip	4	Dust nozzle
5	Front grip	6	Lamp	7	Battery cartridge	8	Lock-off button
9	Wireless activation lamp	10	Wireless activation button	11	Lower guard	12	Caster
13	Shaft lock button	14	Cover	15	Clamp holder	16	Handle
17	Switch trigger	18	Lamp button	19	Overload indicator	20	Hose clamp A
21	Hose clamp B	22	Box wrench	-	-	-	-

FUNCTIONAL DESCRIPTION

CAUTION: Always be sure that the tool is switched off and the battery cartridge is removed before adjusting or checking function on the tool.

Installing or removing battery cartridge

CAUTION: Always switch off the tool before installing or removing of the battery cartridge.

CAUTION: Hold the tool and the battery cartridge firmly when installing or removing battery cartridge. Failure to hold the tool and the battery cartridge firmly may cause them to slip off your hands and result in damage to the tool and battery cartridge and a personal injury.

To install the battery cartridge, align the tongue on the battery cartridge with the groove in the housing and slip it into place. Insert it all the way until it locks in place with a little click. If you can see the red indicator as shown in the figure, it is not locked completely.

To remove the battery cartridges, lift the battery cartridge while pushing the button on the front of the cartridge.

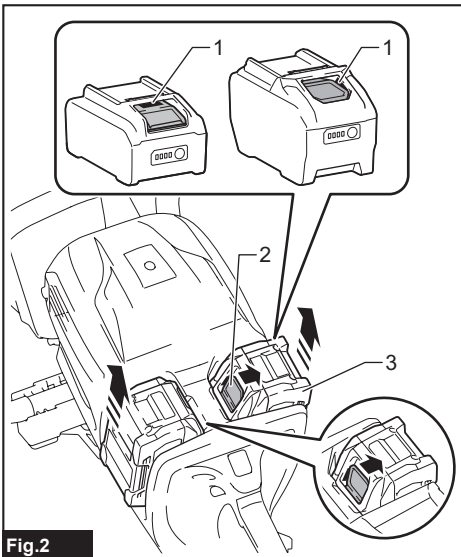

Fig.2

► 1. Red indicator 2. Button 3. Battery cartridge

CAUTION: Always install the battery cartridge fully until the red indicator cannot be seen. If not, it may accidentally fall out of the tool, causing injury to you or someone around you.

CAUTION: Do not install the battery cartridge forcibly. If the cartridge does not slide in easily, it is not being inserted correctly.

NOTE: The tool does not work with only one battery cartridge.

Indicating the remaining battery capacity

Press the check button on the battery cartridge to indicate the remaining battery capacity. The indicator lamps light up for a few seconds.

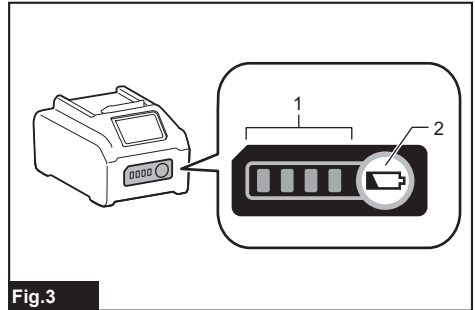

Fig.3

► 1. Indicator lamps 2. Check button

Indicator lamps			Remaining capacity
Lighted	Off	Blinking	
			75% to 100%
			50% to 75%
			25% to 50%
			0% to 25%
			Charge the battery.
			The battery may have malfunctioned.

NOTE: Depending on the conditions of use and the ambient temperature, the indication may differ slightly from the actual capacity.

NOTE: The first (far left) indicator lamp will blink when the battery protection system works.

Tool / battery protection system

The tool is equipped with a tool/battery protection system. This system automatically cuts off power to the motor to extend tool and battery life. The tool will automatically stop during operation if the tool or battery is placed under one of the following conditions.

Overload protection

When the tool/battery is operated in a manner that causes it to draw an abnormally high current, the tool automatically stops. In this situation, turn the tool off and stop the application that caused the tool to become overloaded. Then turn the tool on to restart.

Overheat protection

When the tool/battery is overheated, the tool stops automatically, and the lamp blinks. In this situation, let the tool cool down before turning the tool on again.

Overdischarge protection

When the battery capacity becomes low, the tool stops automatically, and the indicator lamp of battery cartridge blinks. If the tool does not operate even when the switches are operated, remove the batteries from the tool and charge the batteries.

Protections against other causes

Protection system is also designed for other causes that could damage the tool and allows the tool to stop automatically. Take all the following steps to clear the causes, when the tool has been brought to a temporary halt or stop in operation.

1. Turn the tool off, and then turn it on again to restart.
2. Charge the battery(ies) or replace it/them with recharged battery(ies).
3. Let the tool and battery(ies) cool down.

If no improvement can be found by restoring protection system, then contact your local Makita Service Center.

NOTICE: If the tool stops due to a cause not described above, refer to the section for troubleshooting.

Overload alert

If the tool is operated with excessive load, the overload indicator will blink in red. In this situation, reduce the load on the tool. Then, the indicator stops blinking.

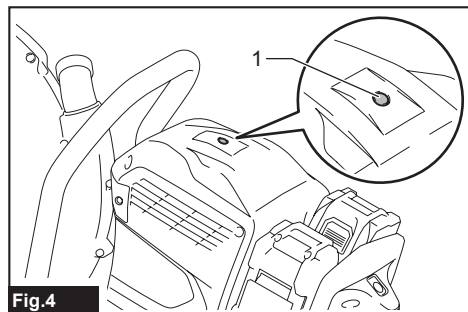

Fig.4
▶ 1. Overload indicator

Switch action

⚠ WARNING: Before installing the battery cartridge into the tool, always check to see that the switch trigger actuates properly and returns to the "OFF" position when released.

⚠ WARNING: NEVER defeat the lock-off button by taping down or some other means. A switch with a negated lock-off button may result in unintentional operation and serious personal injury.

⚠ WARNING: NEVER use the tool if it runs when you simply pull the switch trigger without pressing the lock-off button. A switch in need of repair may result in unintentional operation and serious personal injury. Return tool to a Makita service center for proper repairs BEFORE further usage.

To prevent the switch trigger from being accidentally pulled, a lock-off button is provided. To start the tool, depress the lock-off button and pull the switch trigger. Release the switch trigger to stop.

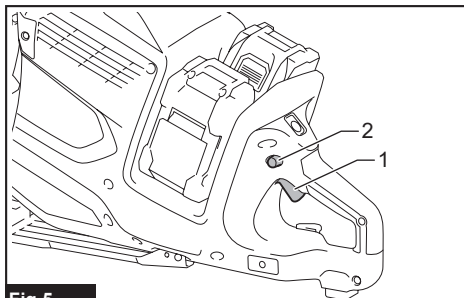

Fig.5
▶ 1. Switch trigger 2. Lock-off button

NOTICE: Do not pull the switch trigger hard without pressing in the lock-off button. This can cause switch breakage.

Lighting the lamp

⚠ CAUTION: Do not look in the light or see the source of light directly.

To turn on the lamp, press the lamp button. To turn off, press the lamp button again.

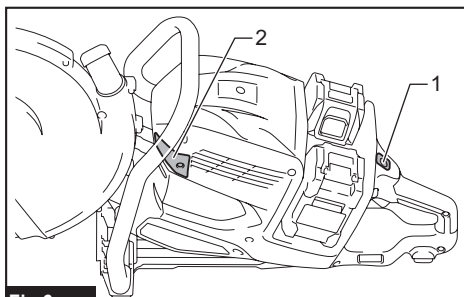

Fig.6
▶ 1. Lamp button 2. Lamp

NOTE: The lamp will automatically be turned off if there is no operation with the tool for one minute.

Adjusting the wheel cover

Hold the wheel cover grip and adjust the position of the wheel cover suitable for your work.

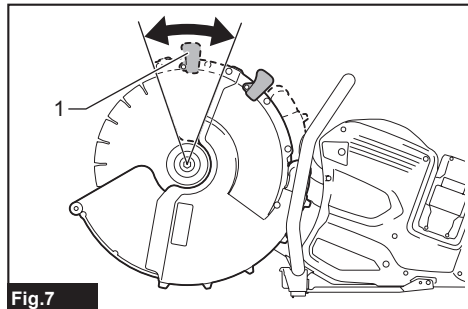

Fig.7

▶ 1. Wheel cover grip

Active feedback sensing technology

The tool electronically detects situations where the wheel may be at risk to be bound. In the situation, the tool is automatically shut off to prevent further rotation of the spindle (it does not prevent kickback).

To restart the tool, switch off the tool first, remove the cause of sudden drop in the rotation speed, and then turn the tool on.

Electric brake

Electric brake is activated after the tool is switched off. The brake does not work when the power supply is shut down, such as the battery is removed accidentally, with the switch still on.

ASSEMBLY

CAUTION: Always be sure that the tool is switched off and the battery cartridge is removed before carrying out any work on the tool.

Installing or removing diamond wheel

CAUTION: Use only the Makita wrench to install or remove the wheel.

CAUTION: When installing the wheel, be sure to tighten the bolt securely.

CAUTION: Do not press the shaft lock button when the wheel is rotating.

To remove the wheel, press the shaft lock button and rotate the wheel until the wheel cannot revolve. While the shaft lock is fully locked, turn the hex bolt counter-clockwise using the box wrench. Then remove the hex bolt, flange, wheel, ring, and flange in order.

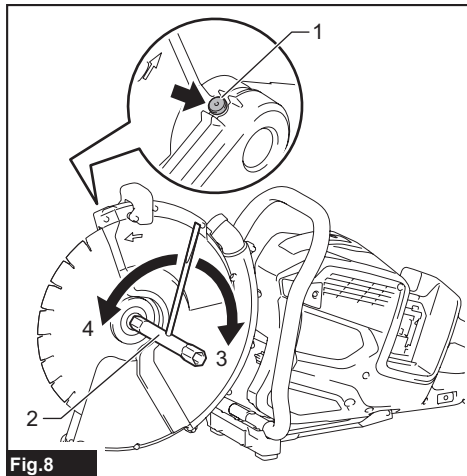

Fig.8

▶ 1. Shaft lock button 2. Box wrench 3. Tighten
4. Loosen

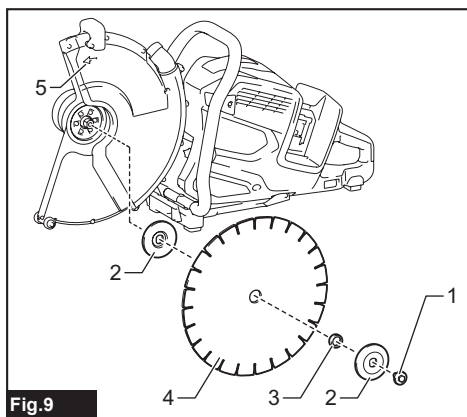

Fig.9

▶ 1. Hex bolt 2. Flange 3. Ring 4. Diamond wheel
5. Arrow (rotation direction of the wheel)

To install the wheel, follow the removal procedure in reverse.

BE SURE TO TIGHTEN THE HEX BOLT SECURELY.

CAUTION: Always install the wheel so that the arrow on it points in the same direction as the arrow on the wheel cover. Otherwise the wheel rotates in reverse, it may cause personal injury.

CAUTION: Only use the wheel that are marked with a speed equal or higher than the speed marked on the tool.

NOTE: When installing the wheel, be sure to attach the flanges so that the flat side of flange faces the wheel, and attach the ring that matches the inner diameter of the wheel.

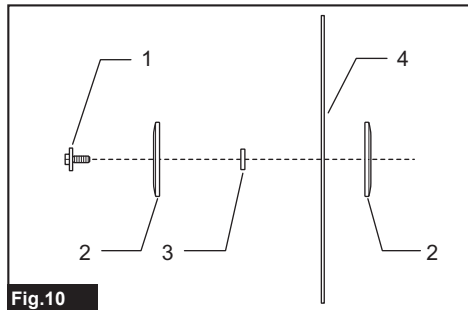

Fig.10

► 1. Hex bolt 2. Flange 3. Ring 4. Diamond wheel

Connecting a vacuum cleaner

NOTICE: Always close the cap when not connecting a vacuum cleaner.

When you wish to perform clean cutting operation, connect a Makita vacuum cleaner to your tool.

Open the cap and connect a hose of the vacuum cleaner.

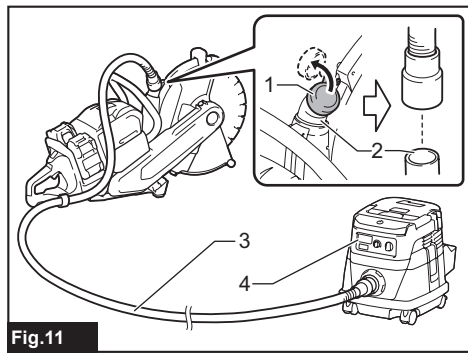

Fig.11

► 1. Cap 2. Dust nozzle 3. Hose 4. Vacuum cleaner

You can change the angle of the dust nozzle as shown in the figure.

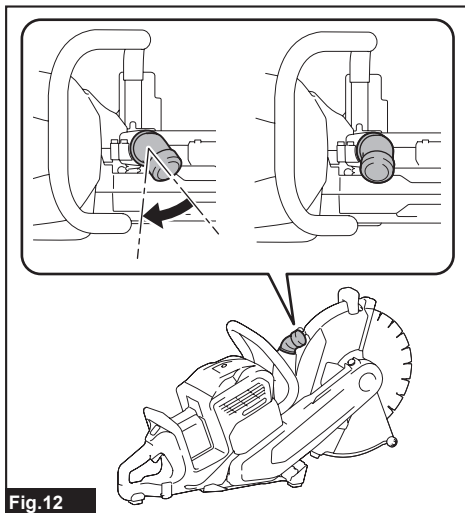

Fig.12

Hose clamp

NOTICE: Always remove the hose clamp from the tool when not in use.

NOTICE: Do not open or close the hose clamp excessively. Otherwise the hose clamp may be broken.

For easy handling of the hose of vacuum cleaner, hose clamp can be attached

1. Attach the hose clamp A or hose clamp B on the hose.

Type	Applicable outer diameter of hose
Hose clamp A	ø 40 mm - ø 46 mm (ø 1-9/16" - ø 1-13/16")
Hose clamp B	ø 35 mm - ø 40 mm (ø 1-3/8" - ø 1-9/16")

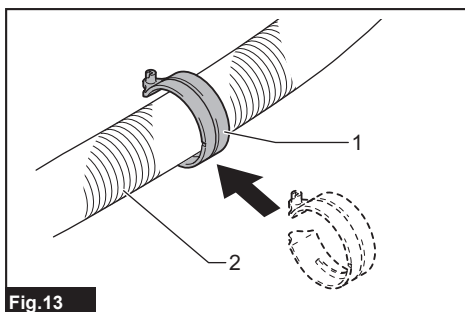

Fig.13

► 1. Hose clamp A / Hose clamp B 2. Hose

2. Insert the pins of hose clamp into the holes of clamp holder.

Make sure the two pins are fit in the holes.

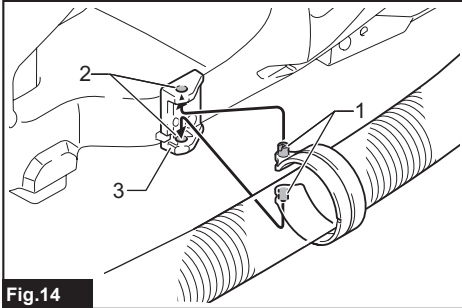

Fig.14

- 1. Pin 2. Hole 3. Clamp holder

3. To remove the hose clamp, follow the installation procedure in reverse.

Box wrench storage

When not in use, store the box wrench as shown in the figure to keep it from being lost.

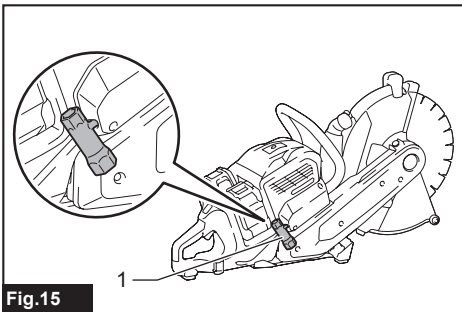

Fig.15

- 1. Box wrench

OPERATION

Checking the lower guard function

Remove the battery cartridge.

Retract the lower guard manually to the end and release it. The lower guard is properly functioning if;

- it is retracted without any hindrance and;
- it automatically returns to the original position.

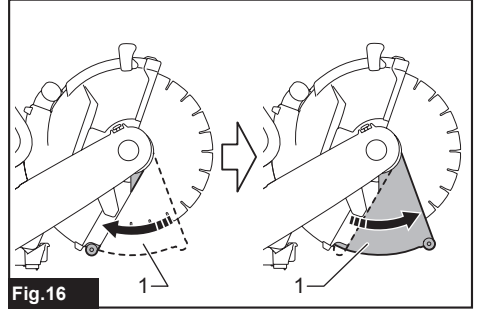

Fig.16

- 1. Lower guard

If the lower guard is not functioning properly, check if dust is accumulated inside of the wheel cover. Some dust may be removed by retracting and returning the lower guard several times.

If the lower guard is not functioning properly even after removing dust, have your machine serviced at a Makita service center.

Notification about the abnormal noise

NOTICE: Do not use distorted or old diamond wheel. Otherwise malfunction, abnormal noise, or breakage may occur.

Even if the diamond wheel is new and without distortion, the diamond wheel may make abnormal noise such as metal friction when the tool is running at low speed. This is not malfunction of the tool.

Some kind of diamond wheel may make abnormal noise when the tool running at low speed. It is because the diamond wheel and the wheel cover are positioned very close for efficient dust collection.

Run the tool at full speed and operate proper cutting. The abnormal noise will be relieved.

Cutting operation

⚠ CAUTION: Be sure to hold the workpiece firmly down on a stable bench or table during operation.

⚠ CAUTION: Do not twist or force the tool in the cut, or the motor may be overloaded or the workpiece may break.

⚠ CAUTION: During operation, do not bring the tool higher than your shoulder height.

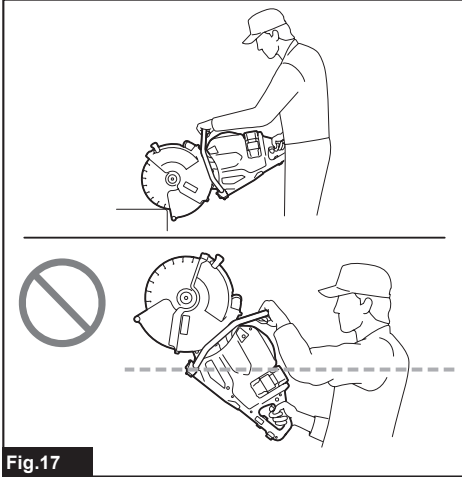

Fig.17

1. Hold the tool firmly. Grasp the handle with your right hand and the front grip with your left hand. To prevent electric shock by accidental cutting of an electric cable, always hold the front grip by the designated portion as shown in the figure.

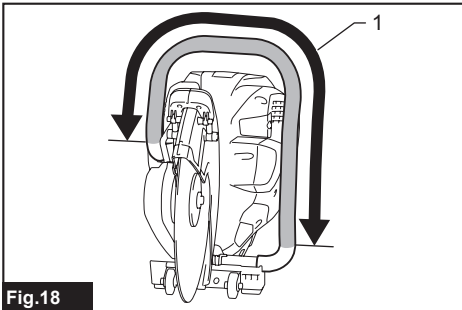

Fig.18

► 1. Part to hold

2. Switch on the tool without the diamond wheel making any contact and wait until the diamond wheel attains full speed.

3. Gently insert the diamond wheel straight into the workpiece, and slide the tool backward smoothly until the cutting is completed.

- Keep cutting line straight and sliding speed uniform.

- Slide the tool in the direction of the arrow on the lower guard.

If you move the tool forward (If you slide the tool in the opposite direction of the arrow), the dust collection efficiency will significantly decrease.

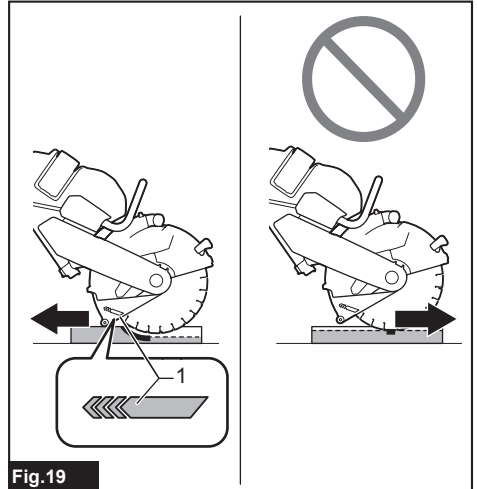

Fig.19

► 1. Arrow

- Keep applying the lower guard to the workpiece. If there is a clearance gap between the lower guard and the workpiece, dust will leak and the dust collection efficiency will decrease.

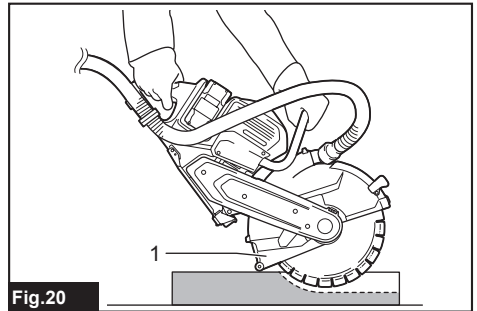

Fig.20

► 1. Lower guard

NOTE: When the battery cartridge temperature is low, the tool may not work to its full capacity. At this time, for example, use the tool for a light-duty cut for a while until the battery cartridge warms up as high as room temperature. Then, the tool can work to its full capacity.

NOTE: If the cutting action of the diamond wheel begins to diminish, dress the cutting edge of the wheel using an old discarded coarse grit bench grinder wheel or concrete block. Dress by pressing lightly on the outer edge of the diamond wheel.

WIRELESS ACTIVATION FUNCTION

Optional accessory

NOTICE: Install the optional dust cover and accessories before using this function.

What you can do with the wireless activation function

The wireless activation function enables clean and comfortable operation. By connecting a supported vacuum cleaner to the tool, you can run the vacuum cleaner automatically along with the switch operation of the tool.

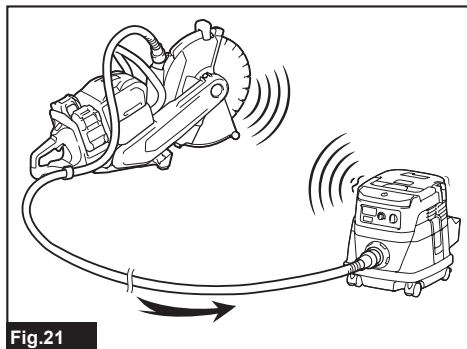

To use the wireless activation function, prepare following items:

- A wireless unit (optional accessory)
- A vacuum cleaner which supports the wireless activation function

The overview of the wireless activation function setting is as follows. Refer to each section for detail procedures.

1. Installing the wireless unit
2. Tool registration for the vacuum cleaner
3. Starting the wireless activation function

Installing the wireless unit

Optional accessory

CAUTION: Place the tool on a flat and stable surface when installing the wireless unit.

NOTICE: Clean the dust and dirt on the tool before installing the wireless unit. Dust or dirt may cause malfunction if it comes into the slot of the wireless unit.

NOTICE: To prevent the malfunction caused by static, touch a static discharging material, such as a metal part of the tool, before picking up the wireless unit.

NOTICE: When installing the wireless unit, always be sure that the wireless unit is inserted in the correct direction and the lid is completely closed.

1. Open the lid on the tool as shown in the figure.

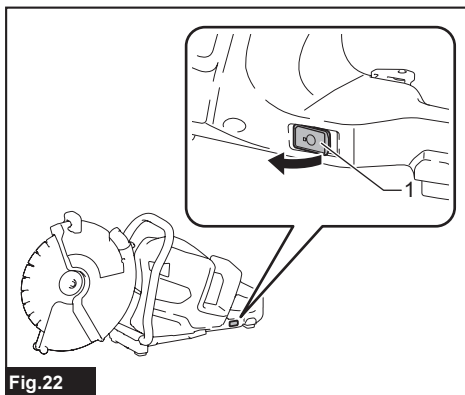

- ▶ 1. Lid

2. Insert the wireless unit to the slot and then close the lid.

When inserting the wireless unit, align the projections with the recessed portions on the slot.

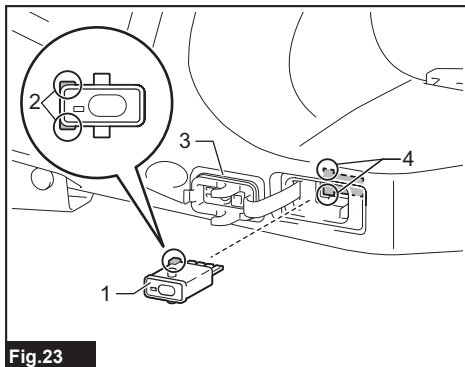

- ▶ 1. Wireless unit 2. Projection 3. Lid 4. Recessed portion

When removing the wireless unit, open the lid slowly. The hooks on the back of the lid will lift the wireless unit as you pull up the lid.

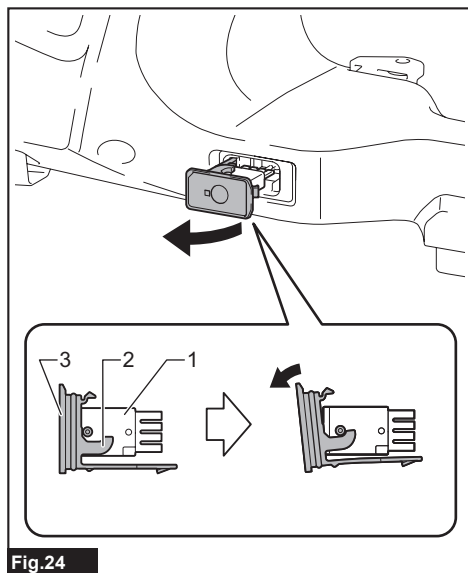

Fig.24

► 1. Wireless unit 2. Hook 3. Lid

After removing the wireless unit, keep it in the supplied case or a static-free container.

NOTICE: Always use the hooks on the back of the lid when removing the wireless unit. If the hooks do not catch the wireless unit, close the lid completely and open it slowly again.

Tool registration for the vacuum cleaner

NOTE: A Makita vacuum cleaner supporting the wireless activation function is required for the tool registration.

NOTE: Finish installing the wireless unit to the tool before starting the tool registration.

NOTE: During the tool registration, do not pull the switch trigger or turn on the power switch on the vacuum cleaner.

NOTE: Refer to the instruction manual of the vacuum cleaner, too.

If you wish to activate the vacuum cleaner along with the switch operation of the tool, finish the tool registration beforehand.

1. Install the batteries to the vacuum cleaner and the tool.

2. Set the stand-by switch on the vacuum cleaner to "AUTO".

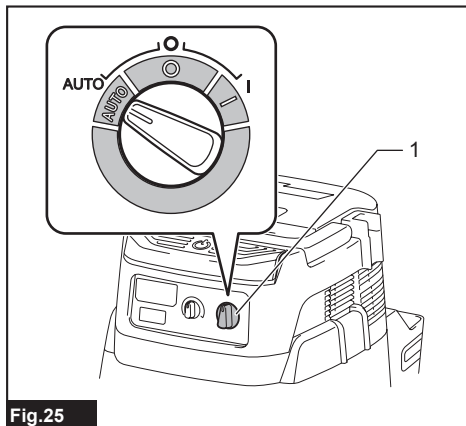

Fig.25

► 1. Stand-by switch

3. Press the wireless activation button on the vacuum cleaner for 3 seconds until the wireless activation lamp blinks in green. And then press the wireless activation button on the tool in the same way.

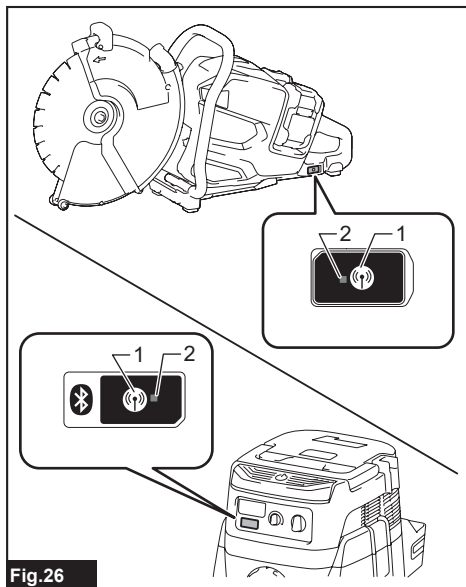

Fig.26

► 1. Wireless activation button 2. Wireless activation lamp

If the vacuum cleaner and the tool are linked successfully, the wireless activation lamps will light up in green for 2 seconds and start blinking in blue.

NOTE: The wireless activation lamps finish blinking in green after 20 seconds elapsed. Press the wireless activation button on the tool while the wireless activation lamp on the cleaner is blinking. If the wireless activation lamp does not blink in green, push the wireless activation button briefly and hold it down again.

NOTE: When performing two or more tool registrations for one vacuum cleaner, finish the tool registration one by one.

Starting the wireless activation function

NOTE: Finish the tool registration for the vacuum cleaner prior to the wireless activation.

NOTE: Refer to the instruction manual of the vacuum cleaner, too.

After registering a tool to the vacuum cleaner, the vacuum cleaner will automatically runs along with the switch operation of the tool.

1. Install the wireless unit to the tool.
2. Connect the hose of the vacuum cleaner with the tool.

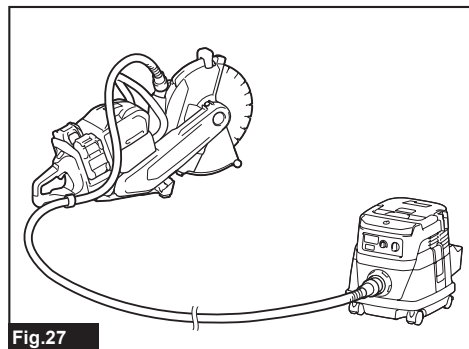

Fig.27

3. Set the stand-by switch on the vacuum cleaner to "AUTO".

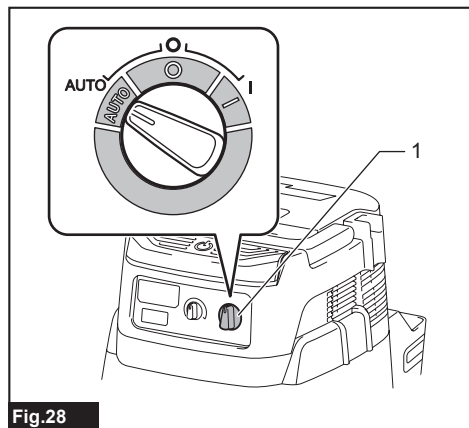

Fig.28

1. Stand-by switch

4. Push the wireless activation button on the tool briefly. The wireless activation lamp will blink in blue.

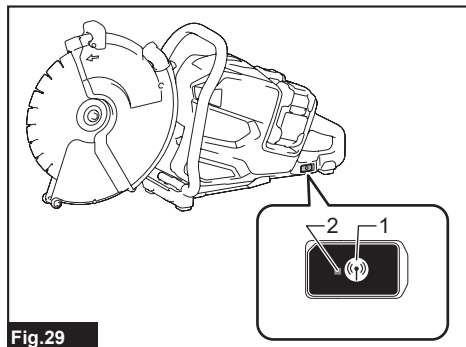

Fig.29

1. Wireless activation button 2. Wireless activation lamp

5. Turn on the tool. Check if the vacuum cleaner runs while the tool is operating.

To stop the wireless activation of the vacuum cleaner, push the wireless activation button on the tool.

NOTE: The wireless activation lamp on the tool will stop blinking in blue when there is no operation for 2 hours. In this case, set the stand-by switch on the vacuum cleaner to "AUTO" and push the wireless activation button on the tool again.

NOTE: The vacuum cleaner starts/stops with a delay. There is a time lag when the vacuum cleaner detects a switch operation of the tool.

NOTE: The transmission distance of the wireless unit may vary depending on the location and surrounding circumstances.

NOTE: When two or more tools are registered to one vacuum cleaner, the vacuum cleaner may start running even if you do not turn on your tool because another user is using the wireless activation function.

Description of the wireless activation lamp status

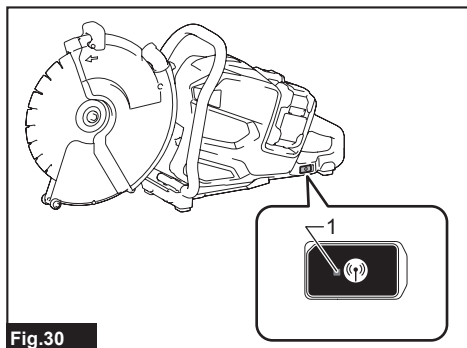

Fig.30

► **1. Wireless activation lamp**

The wireless activation lamp shows the status of the wireless activation function. Refer to the table below for the meaning of the lamp status.

Status	Wireless activation lamp				Description
	Color	■ On	▣ Blinking	Duration	
Standby	Blue		▣	2 hours	The wireless activation of the vacuum cleaner is available. The lamp will automatically turn off when no operation is performed for 2 hours.
		■		When the tool is running.	The wireless activation of the vacuum cleaner is available and the tool is running.
Tool registration	Green		▣	20 seconds	Ready for the tool registration. Waiting for the registration by the vacuum cleaner.
		■		2 seconds	The tool registration has been finished. The wireless activation lamp will start blinking in blue.
Cancelling tool registration	Red		▣	20 seconds	Ready for the cancellation of the tool registration. Waiting for the cancellation by the vacuum cleaner.
		■		2 seconds	The cancellation of the tool registration has been finished. The wireless activation lamp will start blinking in blue.
Others	Red	■		3 seconds	The power is supplied to the wireless unit and the wireless activation function is starting up.
	Off	-		-	The wireless activation of the vacuum cleaner is stopped.

Cancelling tool registration for the vacuum cleaner

Perform the following procedure when cancelling the tool registration for the vacuum cleaner.

1. Install the batteries to the vacuum cleaner and the tool.
2. Set the stand-by switch on the vacuum cleaner to "AUTO".

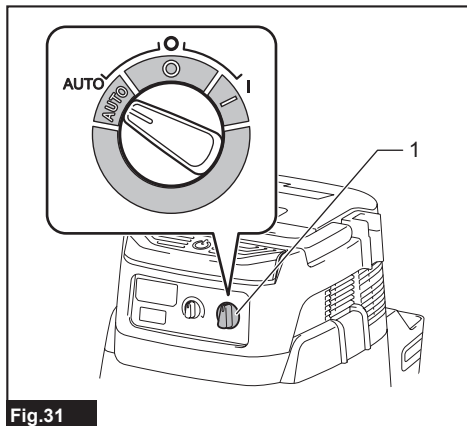

Fig.31

- 1. Stand-by switch

3. Press the wireless activation button on the vacuum cleaner for 6 seconds. The wireless activation lamp blinks in green and then become red. After that, press the wireless activation button on the tool in the same way.

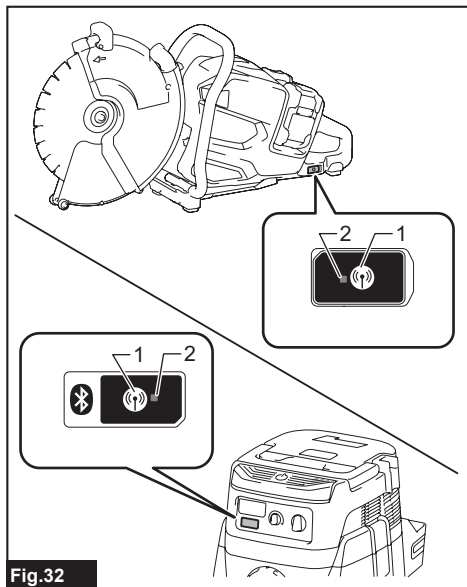

Fig.32

- 1. Wireless activation button 2. Wireless activation lamp

If the cancellation is performed successfully, the wireless activation lamps will light up in red for 2 seconds and start blinking in blue.

NOTE: The wireless activation lamps finish blinking in red after 20 seconds elapsed. Press the wireless activation button on the tool while the wireless activation lamp on the cleaner is blinking. If the wireless activation lamp does not blink in red, push the wireless activation button briefly and hold it down again.

Troubleshooting for wireless activation function

Before asking for repairs, conduct your own inspection first. If you find a problem that is not explained in the manual, do not attempt to dismantle the tool. Instead, ask Makita Authorized Service Centers, always using Makita replacement parts for repairs.

State of abnormality	Probable cause (malfunction)	Remedy
The wireless activation lamp does not light/blink.	The wireless unit is not installed into the tool. The wireless unit is improperly installed into the tool.	Install the wireless unit correctly.
	The terminal of the wireless unit and/or the slot is dirty.	Gently wipe off dust and dirt on the terminal of the wireless unit and clean the slot.
	The wireless activation button on the tool has not been pushed.	Push the wireless activation button on the tool briefly.
	The stand-by switch on the vacuum cleaner is not set to "AUTO".	Set the stand-by switch on the vacuum cleaner to "AUTO".
	No power supply	Supply the power to the tool and the vacuum cleaner.
Cannot finish tool registration / cancelling tool registration successfully.	The wireless unit is not installed into the tool. The wireless unit is improperly installed into the tool.	Install the wireless unit correctly.
	The terminal of the wireless unit and/or the slot is dirty.	Gently wipe off dust and dirt on the terminal of the wireless unit and clean the slot.
	The stand-by switch on the vacuum cleaner is not set to "AUTO".	Set the stand-by switch on the vacuum cleaner to "AUTO".
	No power supply	Supply the power to the tool and the vacuum cleaner.
	Incorrect operation	Push the wireless activation button briefly and perform the tool registration/cancellation procedures again.
	The tool and vacuum cleaner are away from each other (out of the transmission range).	Get the tool and vacuum cleaner closer to each other. The maximum transmission distance is approximately 10 m however it may vary according to the circumstances.
	Before finishing the tool registration/cancellation; - the switch of the tool is turned on or; - the power button on the vacuum cleaner is turned on.	Push the wireless activation button briefly and perform the tool registration/cancellation procedures again.
	The tool registration procedures for the tool or vacuum cleaner have not finished.	Perform the tool registration procedures for both the tool and the vacuum cleaner at the same timing.
	Radio disturbance by other appliances which generate high-intensity radio waves.	Keep the tool and vacuum cleaner away from the appliances such as Wi-Fi devices and microwave ovens.
The vacuum cleaner does not run along with the switch operation of the tool.	The wireless unit is not installed into the tool. The wireless unit is improperly installed into the tool.	Install the wireless unit correctly.
	The terminal of the wireless unit and/or the slot is dirty.	Gently wipe off dust and dirt on the terminal of the wireless unit and clean the slot.
	The wireless activation button on the tool has not been pushed.	Push the wireless activation button briefly and make sure that the wireless activation lamp is blinking in blue.
	The stand-by switch on the vacuum cleaner is not set to "AUTO".	Set the stand-by switch on the vacuum cleaner to "AUTO".
	More than 10 tools are registered to the vacuum cleaner.	Perform the tool registration again. If more than 10 tools are registered to the vacuum cleaner, the tool registered earliest will be cancelled automatically.
	The vacuum cleaner erased all tool registrations.	Perform the tool registration again.
	No power supply	Supply the power to the tool and the vacuum cleaner.
	The tool and vacuum cleaner are away from each other (out of the transmission range).	Get the tool and vacuum cleaner closer each other. The maximum transmission distance is approximately 10 m however it may vary according to the circumstances.
Radio disturbance by other appliances which generate high-intensity radio waves.	Keep the tool and vacuum cleaner away from the appliances such as Wi-Fi devices and microwave ovens.	
The vacuum cleaner runs while the tool is not operating.	Other users are using the wireless activation of the vacuum cleaner with their tools.	Turn off the wireless activation button of the other tools or cancel the tool registration of the other tools.

MAINTENANCE

CAUTION: Always be sure that the tool is switched off and the battery cartridge is removed before attempting to perform inspection or maintenance.

NOTICE: Never use gasoline, benzine, thinner, alcohol or the like. Discoloration, deformation or cracks may result.

To maintain product SAFETY and RELIABILITY, repairs, any other maintenance or adjustment should be performed by Makita Authorized or Factory Service Centers, always using Makita replacement parts.

Cleaning the tool

NOTICE: Do not wash the tool with water.

After each use, remove the battery cartridges and the wheel, and then clean dust or dirt accumulated inside the wheel cover. Clean the tool body by wiping off dust, dirt with a dry cloth or one dipped in soapy water and wrung out. Use a dry cloth to wipe the dirt off the lens of the lamp. Be careful not to scratch the lens of lamp, or it may lower the illumination.

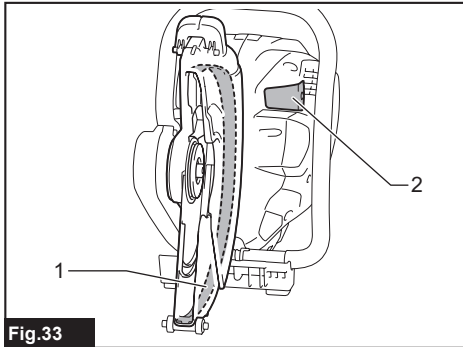

Fig.33

► 1. Wheel cover 2. Lens of the lamp

Cleaning the air vent

Regularly clean the tool's air vents or whenever the vents start to become obstructed.

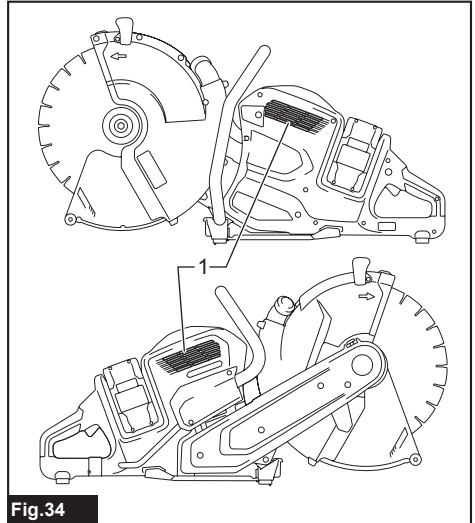

Fig.34

► 1. Air vent

Replacing the synchro-belt

1. Remove the battery cartridges and the wheel.
2. Loosen the hex socket bolts using the tip of the box wrench, and then remove the cover.

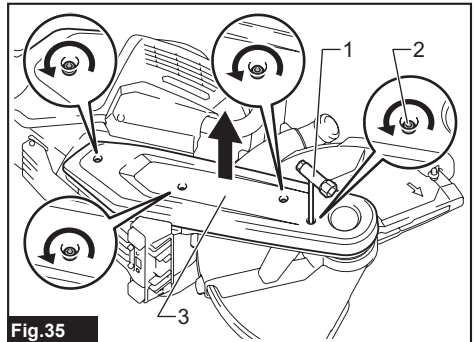

Fig.35

► 1. Box wrench 2. Hex socket bolt 3. Cover

3. Push in the shaft lock button and hold it to lock the large pulley, and then turn the nut counterclockwise using the thin end of the box wrench.

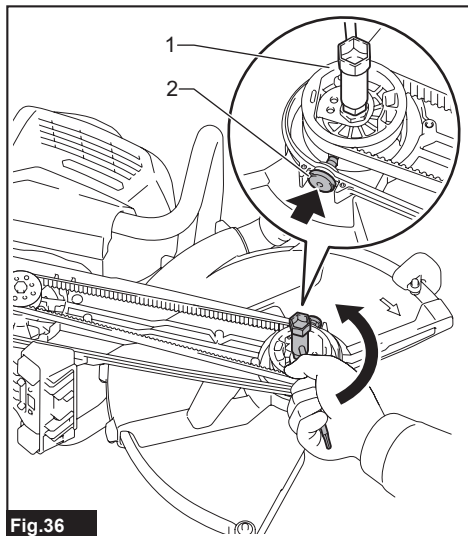

Fig. 36

- 1. Large pulley 2. Shaft lock button

4. Push in the shaft lock button and hold it to lock the large pulley, and then turn the small disc counterclockwise using the thick end of the box wrench to loosen the synchro-belt.

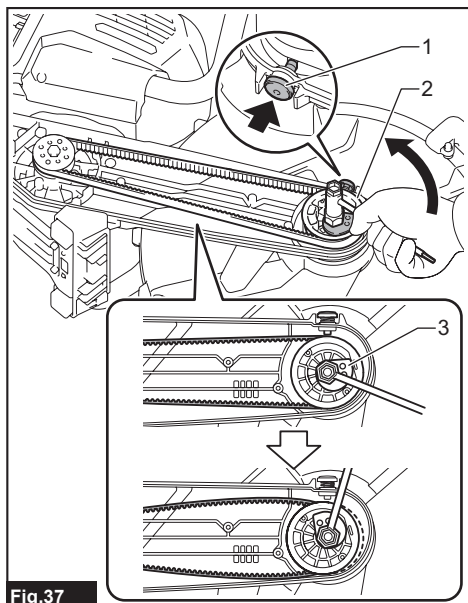

Fig. 37

- 1. Shaft lock button 2. Large pulley 3. Small disc

5. Remove the belt.

6. With the grooves on the belt inside, attach one end of the belt to the small pulley, and then attach the other end of the belt to the large pulley.

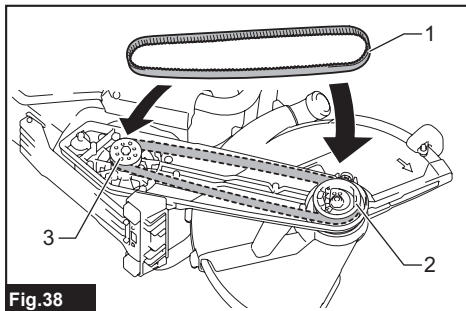

Fig. 38

- 1. Belt 2. Large pulley 3. Small pulley

7. Push in the shaft lock button and hold it to lock the large pulley, and then turn the small disc clockwise using the thick end of the box wrench to tighten the belt.

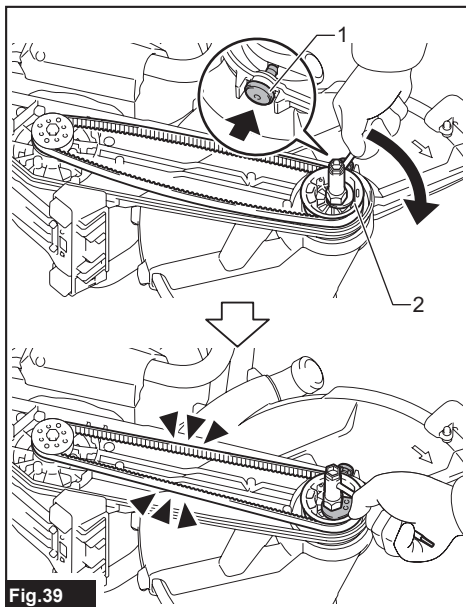

Fig. 39

- 1. Shaft lock button 2. Large pulley

NOTE: Make sure that the small disc is in the position shown in the figure.

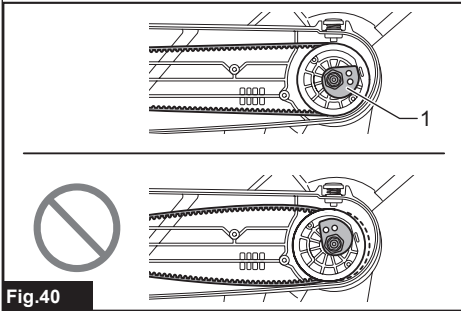

Fig.40

► 1. Small disc

8. Push in the shaft lock button and hold it to lock the large pulley, and then turn the nut clockwise using the thin end of the box wrench.

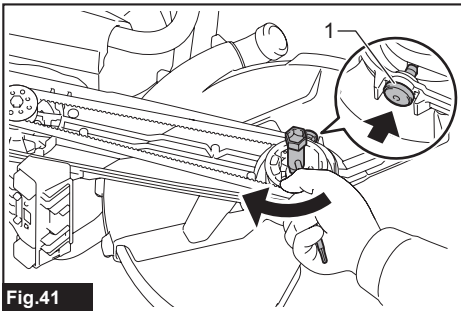

Fig.41

► 1. Shaft lock button

NOTE: When tightening the nut, apply 19 - 21 N•m as tightening torque.

9. Attach the cover, and then tighten the hex socket bolts using the tip of the box wrench.

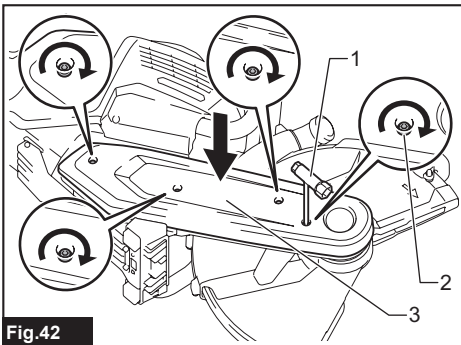

Fig.42

► 1. Box wrench 2. Hex socket bolt 3. Cover

TROUBLESHOOTING

Before asking for repairs, conduct your own inspection first. If you find a problem that is not explained in the manual, do not attempt to dismantle the tool. Instead, ask Makita Authorized Service Centers, always using Makita replacement parts for repairs.

State of abnormality	Probable cause (malfunction)	Remedy
Motor does not run.	Battery cartridges are not installed.	Install two battery cartridges. This tool does not work with one battery cartridge.
	Battery problem (under voltage)	Recharge the battery. If recharging is not effective, replace the battery cartridge.
	The drive system does not work correctly.	Ask your local authorized service center for repair.
Motor stops running after a little use.	Battery's charge level is low.	Recharge the battery. If recharging is not effective, replace the battery cartridge.
	Overheating.	Stop using of tool to allow it to cool down.
The wheel rotation does not accelerate properly even after running the tool without load for 20 seconds.	Battery is installed improperly.	Install the battery cartridges as described in this manual.
	Battery power is dropping.	Recharge the battery cartridges. If recharging is not effective, replace the battery cartridge.
	The synchro-belt is slipping.	Replace the synchro-belt with new one.
	The drive system does not work correctly.	Ask your local authorized service center for repair.
Wheel does not rotate: ⇒ Stop the machine immediately!	The synchro-belt is slipping.	Replace the synchro-belt with new one.
	Foreign object is jammed between the wheel cover and the wheel.	Uninstall the battery cartridges and then remove the foreign object.
	The drive system does not work correctly.	Ask your local authorized service center for repair.
Abnormal vibration: ⇒ Stop the machine immediately!	Improper attachment of the wheel.	Install the wheel as instructed in this manual. Tighten the bolt to secure the wheel firmly.
	The drive system does not work correctly.	Ask your local authorized service center for repair.
Cutting tool and motor cannot stop: ⇒ Remove the battery cartridge immediately!	Electric or electronic malfunction.	Remove the battery cartridges, and ask your local authorized service center for repair.
Poor cutting performance	It is time to replace the wheel.	Replace the wheel with new one.
Weak suction power of the vacuum cleaner.	The filter of the vacuum cleaner is clogged.	Clean the filter. If cleaning the filter does not solve the problem, replace the filter.
The lower guard is not properly functioning.	Dust is accumulated inside of the wheel cover.	Retract and return the lower guard several times.

OPTIONAL ACCESSORIES

⚠ CAUTION: These accessories or attachments are recommended for use with your Makita tool specified in this manual. The use of any other accessories or attachments might present a risk of injury to persons. Only use accessory or attachment for its stated purpose.

If you need any assistance for more details regarding these accessories, ask your local Makita Service Center.

- Diamond wheel
- Ring set
- Synchro-belt
- Box wrench
- Wireless unit
- Makita genuine battery and charger

NOTE: Some items in the list may be included in the tool package as standard accessories. They may differ from country to country.

Makita Europe N.V. Jan-Baptist Vinkstraat 2,
3070 Kortenberg, Belgium

Makita Corporation 3-11-8, Sumiyoshi-cho,
Anjo, Aichi 446-8502 Japan

www.makita.com

885A04-223 EN 20230206
