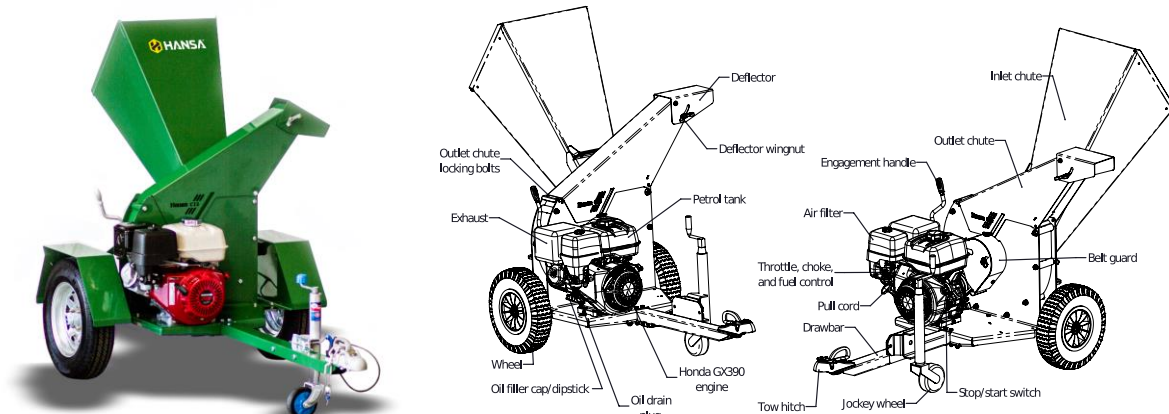

Risk Assessment: C13 wood chipper

Document information			
Risk assessment creation date:		5/07/18	
Created by:		MS	
Revision:	Revision date:	Revision notes:	Revised by:

Equipment information	
Model:	C13
Max power:	11.7 hp
Weight:	150-200 kg
Intended use:	The C13 chipper is intended to process organic material including wooden branches not exceeding 90 mm in diameter. Organic material includes: pruning's, stalks, roots, vegetable matter, hay, grass, bark, dry manure, branches, palm fronds, paper and cardboard. Materials that should not be processed include, but are not limited to: bones, soil, root balls, sand, stones and metal. The organic material is fed into the machine through the inlet chute. The material moves down the inlet chute into the cutting mechanism which cuts the material into smaller pieces and discharges this processed material out of the outlet chute. The road towable model is intended to be towed on the road.
Images:	

Risk assessment

Each hazard is rated from 1 (low) to 5 (high) on severity and probability. The ratings are then multiplied to calculate the overall risk rating from 1 (low) to 25 (high).

Overall risk rating matrix				Severity				
				Major 5	Serious 4	Medium 3	Minor 2	Property 1
The overall risk rating = severity rating multiplied by probability rating				Death or permanent disability	Extensive injuries, but with recovery over time, or serious long term effects to health	Medical treatment from a doctor or serious short-term effects to health	First aid treatment, or nil/minor effects to health	Property damage only
Probability	Certain	5	Event may be expected to occur at any time	25	20	15	10	5
	Likely	4	Event will probably occur in most circumstances	20	16	12	8	4
	Moderate	3	Event may occur occasionally	15	12	9	6	3
	Unlikely	2	Small possibility event may occur at some time	10	8	6	4	2
	Rare	1	Event may only occur in exceptional circumstances	5	4	3	2	1

Hazard:	Risk:	Probability rating:	Severity rating:	Risk rating:	Control measures:
Sound	Damage to hearing	4	2	8	Hearing protection must always be worn. Always keep bystanders at a safe distance away from the machine.

Dust	Injury or irritation of the eyes Respiratory irritation	3	2	6	<p>Wear safety glasses.</p> <p>Avoid directing the discharging air towards dusty ground.</p> <p>Only process freshly cut material and avoid processing material that contains dry dirt.</p> <p>Wear a dust mask if the hazard cannot be eliminated.</p>
Feeding material	Minor cuts and scrapes	3	2	6	<p>Wear safety gloves.</p> <p>Wear tight fitting long sleeves and pants to cover bare skin when operating the machine.</p> <p>Take care when handling material that has thorns and/or sharp edges.</p>
Petrol, oil, grease	Poisoning, skin irritation, inhaling harmful vapours	3	2	6	<p>Avoid contact with petrol, oil and grease.</p> <p>Wear safety glasses and take care when refuelling, changing the oil and greasing.</p> <p>Wash skin immediately if contaminated with petrol, oil or grease.</p> <p>Do not refuel the chipper in enclosed areas.</p> <p>Avoid inhaling fuel vapours.</p>
Cutting rotor and knives	Pinching, crushing, cutting, severing	1	5	5	<p>Operators must read and familiarise themselves with the safe operation information in the operators manual.</p> <p>The inlet chute is designed to restrict the operators ability to reach down into the inlet chute.</p> <p>Do not extend your hands and other body parts down the inlet chute past the rubber flap.</p> <p>Use a stick to push materials into the inlet chute and do not push the stick down past the rubber flap.</p> <p>Do not put your hands or other body parts into the outlet chute.</p> <p>Only operate the machine with all parts fastened in their correct place.</p> <p>Take care and keep your hands away from the blades when inspecting and/or servicing the machine.</p> <p>Tie up long hair, wear tight gloves and tight fitting clothing to avoid getting snagged by material that is being pulled into the cutting mechanism.</p> <p>Always wait for the cutting rotor to stop moving before opening the machine for servicing or clearing a blockage.</p>
Cutting blades and/or other moving	Cutting, severing, crushing	1	5	5	<p>Servicing and maintenance should only be carried out by competent and authorised personnel in accordance with the correct procedures.</p> <p>Torque the knife and anvil bolts to the required torque specifications.</p>

components coming loose					Set the correct knife to anvil distance (during servicing). Do not process non-organic materials that can damage the machine, especially stones and metal. Keep the knives/anvil sharp and do not operate the machine with blunt or damaged knives/anvil.
Moving components	Entanglement	1	5	5	Tie up long hair, wear tight gloves and tight fitting clothing to avoid getting entangled in moving components.
Debris fire	Heat burns, respiratory irritation	1	5	5	Clear any build-up of chipping debris around the engine and exhaust regularly to reduce the risk of debris catching fire.
Fuel fire	Heat burns, respiratory irritation	1	5	5	Visually check the machine for fuel leaks before operating. Take extra care when handling fuel - they are flammable and vapors are explosive. Use only approved fuel container/s. Always replace and securely tighten fuel cap after refuelling. Allow engine to cool down before refuelling. Do not smoke when using or refuelling the chipper. Never remove fuel cap or add fuel with the engine running. Never refuel the chipper indoors. Never store the chipper or fuel container inside where there is an open flame, such as a water heater. If fuel is spilled, do not attempt to start the engine, first wipe up the spilt fuel on the chipper and move the chipper away from the area of spillage before starting.
Machine separates from vehicle during towing on the road	The machine separates from the vehicle resulting in a road accident	1	5	5	Connect the tow coupling to the tow vehicle's tow ball ensuring that the coupling is properly engaged and connected. Check that the tow ball dimensions match the coupling (50 mm or 1 7/8"). Connect the safety chain with shackle. Ensure the jockey wheel is in the up position and locked away during travel.
Road lights do not work correctly	Other motorists do not see the correct trailer light signals resulting in a road accident	1	5	5	Ensure the trailer plug is connected to the tow vehicle and check that the machines road lights are working correctly.

Wheel nuts coming loose	A wheel comes off resulting in a road accident	1	5	5	Periodically check that the wheel nuts are tight.
Hot exhaust	Heat burns	2	2	4	Keep bare hands and other body parts a safe distance away from the exhaust.
Discharge material	Eye injury, minor cuts and/or scrapes	2	2	4	Always wear safety glasses when operating the machine. Keep body parts away from the outlet chute discharge area. Do not put the machinery in a place where the outlet chute is directed on a hard surface which may cause material to ricochet. Always keep bystanders at a safe distance away from the machine.
Weight of the chipper	Straining, crushing	2	2	4	Place the machinery on firm level ground when operating. Take care when lifting and moving the machine. The machine weighs 95 kg. Avoid manually lifting the machine and use ramps or a crane where possible when loading and unloading from a transport vehicle. Multiple people will be required to lift the machine if ramps or a crane are not available.
Exhaust fumes	Respiratory irritation Carbon monoxide poisoning	2	2	4	Place the machine in a location where the operator is not exposed to direct exhaust fumes. Do not operate the machine in an enclosed area as exhaust fumes contain carbon monoxide which is poisonous, colourless, odourless, and tasteless. Only operate the machine in a location that is well ventilated.
Belt drive and engagement system	Skin pinching and/or abrasions	1	2	2	Ensure all guarding is in place and properly secured. Turn off the machine before inspecting and/or servicing the belt drive and engagement system.